

PEER CHAIN
PASSIONATELY PRESENTS

Your Escape Room Guide

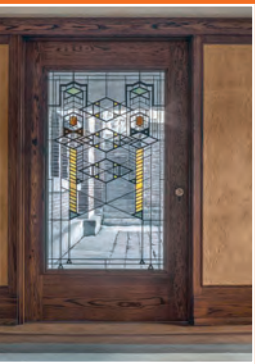

**Featuring
Nine Escape
Rooms...**



**To Find Your
Roller Chain
Solutions**



PEER CHAIN
Quality Links That Last.™

PEER SPROCKETS
PEER Perfectly Pairs.™

Escape Room noun

merriam-webster.com, July 2021

: a game in which participants confined to a room or other enclosed setting are given a set amount of time to find a way to escape (as by discovering hidden clues and solving a series of riddles or puzzles).

"Escape rooms are a game where a group of friends or co-workers get locked into a space to play some puzzles, so they can all win the reward of leaving the room slightly early." – *ND*

Escape Room Guide noun

PEER Chain family definition

peerchain.com, July 2021

: a resource in which power transmission chain users work collaboratively with the PEER Chain family to find a dependable escape route in a timely manner to solve your application needs.

"Our guide is a fun, yet very serious game with options to escape the stress of your sourcing challenges and a way to find your solutions. We welcome you into each room to build a relationship with our family, offering the security of the appropriate product supported by a unique combination of Performance, People and Passion." – *Danny Spungen*

At PEER Chain, we pride ourselves in being unique. We take our passion seriously, and are constantly looking for ways to make ourselves stand out in our industry. What better way to stand out than our product guide?

**By our definition here-on-out, each section of our
Escape Room Guide will be referred to as an Escape Room.**

In the Escape Room Guide you are now reading (either virtually or physically), there are nine Escape Rooms to find your way to the best solutions. Each Escape Room represents a different category of chain: (1) ANSI Standard, (2) ANSI Heavy, (3) Double Pitch, (4) ISO British, (5) Corrosion Resistant, (6) Self-Lube, (7) Attachment Chain, (8) Specialty Chain and (9) Leaf Chain.

What about Agricultural Chain, Engineering Class Chain and, of course, Sprockets? We are in the process of preparing special Escape Room Guides for these products as well – until these guides are finished, you can find these products on our website!

How to Use the Escape Room Guide

While you are searching through our Escape Room Guide for all of your chain requirements, we have some activities to entertain the curious, delight the innovative and challenge the inquisitive. We invite you to enjoy a little bit of fun during your serious search in finding the right solutions to keep your operations running.

At the beginning of each Escape Room, you will find a puzzle. Solve each puzzle to find the cryptic message in each Escape Room. Once you have completed the puzzles, visit our website (peerchain.com) and search for the discrete door and enter! After completing the form, what follows is all about our relationship with you!

Enjoy your journey through our PEER Chain Company Escape Room Guide, and please, if you have any questions at all, reach out to our team personally. We always maintain a physical presence in the office and ready to help during business hours at 1.847.775.4600.



THE SPUNGEN FAMILY WELCOMES YOU!

July 9, 1969 is a birthday that the PEER Chain family is very proud of.

July 9th is our Independence Day of becoming a separate entity from other family units. It's a day filled with celebration and reflection. We often hear that the best quality of a family business is, in fact, family itself. And yes, we often hear that among the challenges of a family business is, in fact, family itself.

The Spungen family did it! Now entering our 4th generation of family ownership in power transmission parts, PEER Chain has been a strong and reliable source grounded in personal relationships with our employees and customers.

Longevity requires a lot of work, sacrifices, and willingness to explore different growth strategies without sacrificing important Spungen business values. We use our anniversary every year to highlight the past and transform the future.

What is in our future? Are we destined to live only "in the cloud"? Living within our software programs? These are very important points, but what technology will not replace is our inherited, passed-down commitments, like inventory. The Spungen family respects the power of inventory and is not afraid of "accounting turns." We invest in what we know, and we know chain and sprockets.

While our investment in technology and inventory is critical, we are passionately committed to our people "on the ground." Our relationships with our employees and customers are paramount. Even after three generations, investments in training will never stop.

The Spungens define "training" as a continuous reinforcement of product knowledge, understanding customer applications, knowing our customers personally, and engaging our employees in as many aspects of the business as possible.

These words are easy to write, challenging to execute, but ultimately, exciting to take on.

In total, we are a family connected by links forged by Performance, People, and Passion. All to keep you running!

Please join us as we guide you through each of our "Escape Rooms", full of industrial chain that will fill your needs. We are delighted that you're here.

Signed,
Glenn, Danny, Charles and Jeffrey



TABLE OF CONTENTS

Escape Guide Theme and “how to” use games	2
Welcome	3
Contents	4-5
Roller Chain Components “basic training”	6-7
Quest™ Information	8-9
ANSI	11-22
ANSI Heavy	23-34



TABLE OF CONTENTS (continued)

Double Pitch	35-41
ISO British	43-49
Corrosion Resistant (2 page spread at beginning)	51-78
Self Lube	79-85
Attachments (2 page spread at beginning)	87-118
Specialty	119-135
Hollow Pin, Sidebow, Snap-On Top Chain, Bindery, Wrench, Poly Stainless, and more	
Leaf Chain	137-142

FUTURE PEER CHAIN ESCAPE ROOM GUIDES TO COME:

Engineering Class Chains

Agricultural Chains

Sprockets

ROLLER CHAIN COMPONENTS

Pin Link

The pin link is considered an outer link. It is constructed with two pin link plates and two pins. The pin link can be riveted or cotter assembly style.

Pin

Pins are the primary load bearing component of chain. They are subject to shearing and bending forces transferred from the plates. Pins are designed to have high strength, toughness, and resistance to wear and shock.

Roller Link

The roller link is an inside link constructed with two roller link plates, two bushings, and two rollers.

Bushing

The bushing is a load-bearing component similar to the pins. In addition to high strength and toughness, they also must also have high-wear resistance to accommodate the articulation of pins and rollers.

Link Plate

Link plates, both roller and pin link, are the primary tension linkage component. They must have excellent tensile and fatigue strength must be able to accommodate heavy shock loads and overcome necessary environmental resistances, such as corrosion and abrasion.

Roller

Rollers assist to smoothly articulate the chain as it engages with a sprocket. The roller must have high resistance to impact, wear, and fatigue.

CHAIN ASSEMBLY

PEER Chain Manufactures both Riveted and Cottered assembly style chains. Riveted chains feature pin link plates punched with an interference fit hole accepting pins that extend thru and are riveted on either side of the link plate. Cottered assembly style chains have the same riveted pin on one side of the chain and extended pins with holes drilled to accept cotter pins on the other.

RIVETED



COTTERED



ROLLER LINK

A roller link is an inside link consisting of two roller link plates, two bushings, and two rollers.

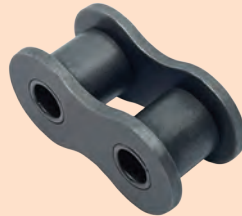

CONNECTING LINK

A connecting link is an outside link consisting of a pin link plate, two assembled pins, and a detachable pin link plate. There are two types of connecting links:

Spring Clip Type

The detachable pin link plate is retained by a spring clip which engages grooves cut in the ends of the pins.



Cotter Pin Type

The detachable pin link plate is retained by two cotters.



OFFSET LINK

An offset link is a link consisting of two offset link plates, a bushing, a roller, a removable pin, and a cotter. The two-pitch offset link consists of a roller link and an offset link, which are connected by a riveted press-fit pin.

One-pitch offset link



Two-pitch offset link



PEER Quest™



CHAIN AVAILABILITY



25-240 Roller Chain Sizes



Sticker/Thermoforming Chain



25-240 Double Strand Chain Sizes



Bindery Chain



C2040-C2120H Extended Pitch Chain



Engineering 81X Chain



Carbon Steel Chains & Attachments



Heavy Series Roller Chain



Sharp Top Chain



British Standard Chain

PEER Quest™ Roller Chain utilizes solid bushing technology to decrease wear and increase chain life. PEER Quest™ Roller Chain takes advantage of an innovative manufacturing process to employ solid one-piece cold forged bushings. The solid bushing provides a smoother and more cylindrical inside bushing wall, which improves the surface contact area between the pin and bushing to outlast split bushing chain. PEER Quest™ Roller Chain is available in single and multiple strand configurations and is well-suited for a vast variety of applications.

QUEST™ INDUSTRY FACT

Bushings are a critical component inside every roller link of roller chain you use.

QUEST™ SOLUTION

Quest™ Solid Bushing Roller Chain is designed to decrease wear and outperforms conventional split bushing roller chains.



CONVENTIONAL SPLIT BUSHING ROLLER CHAINS

- Use split bushings made from flat steel that is curled into shape
- Split bushings tend to become barrel-shaped
- Barrel-shape results in a point-to-point contact
- Point-to-point contact leads to additional elongation and premature wear

PEER QUEST™ SOLID BUSHING ROLLER CHAINS

- Employs solid one-piece cold forged bushings
- Provides a smoother, more cylindrical inside bushing wall
- Contact between pin and bushing is maintained along the entire inside length of bushing
- Lasts longer and performs better

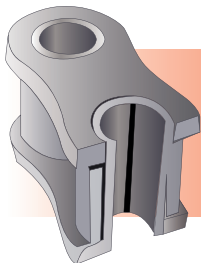

CONVENTIONAL SPLIT BUSHING ROLLER CHAINS

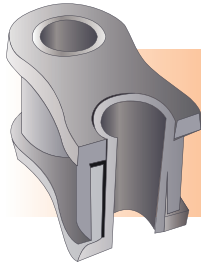

PEER QUEST™ SOLID BUSHING ROLLER CHAINS



QUEST™ INDUSTRY FACT

Is E-lon-ga-tion your worst enemy? We know it's good for high jumps, long jumps, and slam dunks, but not here, in your world, where it counts the most.

QUEST™ SOLUTION

Quest™ chain components are shot peened for greater fatigue resistance. Each Quest™ chain is pre-loaded after assembly to reduce initial chain elongation.

DECREASED CHAIN ELONGATION = INCREASED CHAIN LIFE = ALWAYS RUNNING

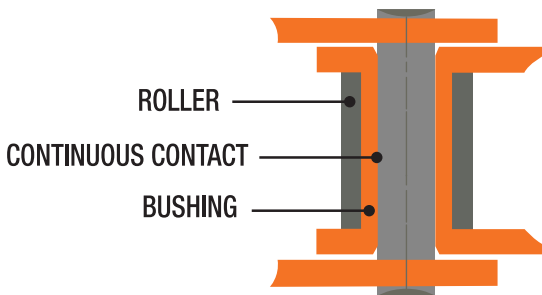
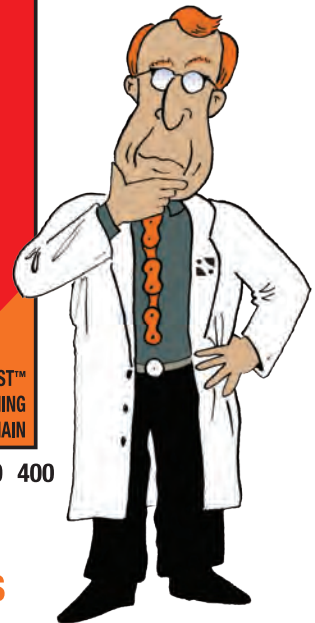
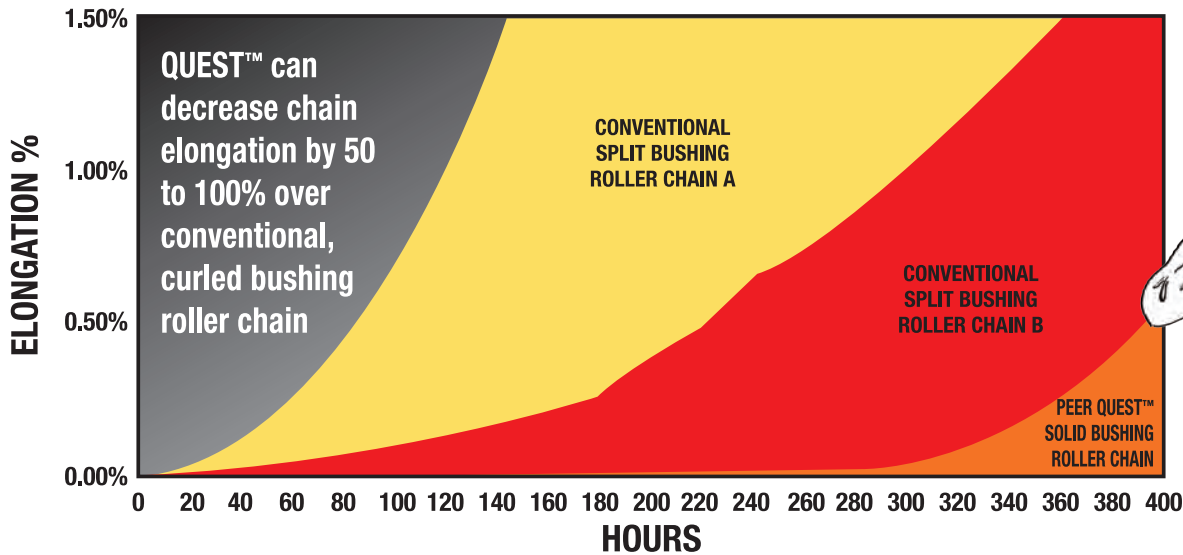

PEER QUEST™ SOLID BUSHING ROLLER CHAINS

- Hot-dipped lubrication ensures 100% lubrication of all chain components
- Results in significantly reduced friction between components
- Extends chain life and reduces maintenance costs

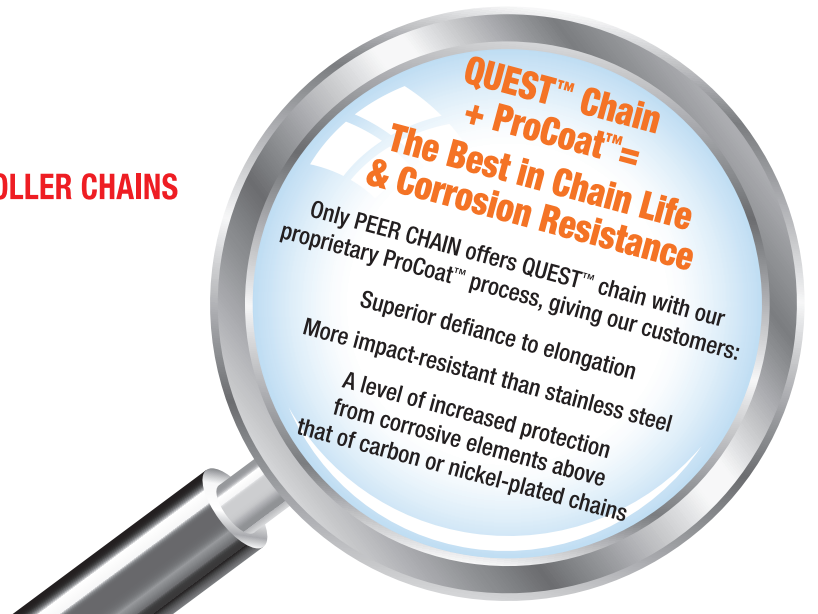
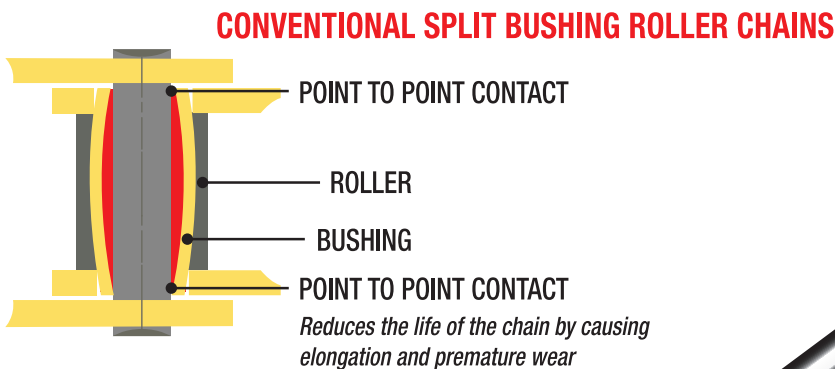



ANSI/ASME STANDARD

Our PEERChain precision roller chains are manufactured to meet or exceed ANSI/ASME B29.1 requirements. Constructed with modern manufacturing practices, standard roller chain is the economical choice. Our ANSI roller chain provides the optimum solution to keep your operation running. In addition to power transmission, ANSI standard roller chain is used in a vast number of other applications. Our chain is engineered for high performance even in the toughest applications. Standard roller chain is available in single strand to multiple strand configurations.

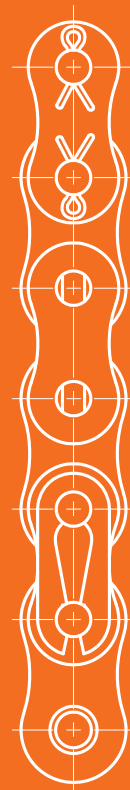

Crossword Game

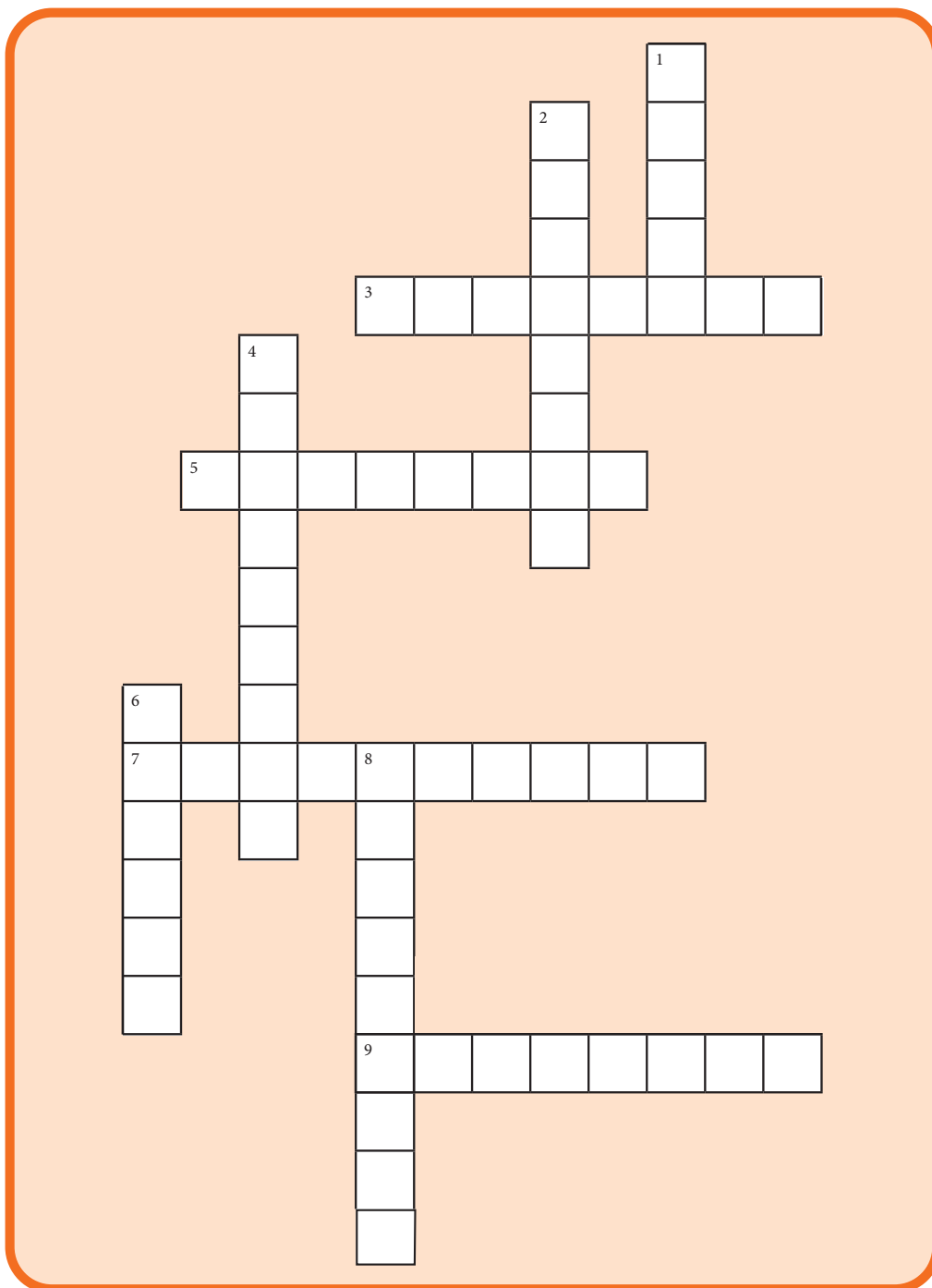

ACROSS

- Country in Southeast Asia with smallest mammal (bat) is found
- Jack Benny was born in the town where PEER Chain is headquartered
- We call it K1 or K2, you call it an _____ .
- Chain commonly coined "maintenance free"

DOWN

- Every single Panda living in the whole world belongs to this country
- My side kick is Boo Boo Bear in Jellystone Park... (or the big dog that follows Danny around)
- Designed to be durable and the opposite of light
- Island about 100 miles or the coast off Southeast China
- Gradual destruction of a material (usually metal) by chemical reaction with the environment

**At the beginning of each Escape Room, you will find a puzzle. Solve each puzzle to find the cryptic message in each Escape Room. Once you have completed the puzzles, visit our website (peerchain.com) and search for the discrete door and enter! Once you complete the form, what follows is all about our relationship with you!*

ANSI/ASME STANDARD ROLLER CHAIN SINGLE STRAND



1. Our PEER Chain precision roller chains are manufactured to **exceed ANSI/ASME B29.1** requirements.
2. All chain components are **heat-treated** to achieve maximum strength and greater wear resistance.
3. All PEER roller chain is **pre-loaded** during the manufacturing process to minimize initial elongation.
4. **Hot-dipped lubrication** ensures 100% lubrication of all chain components to extend wear life and reduce maintenance costs.

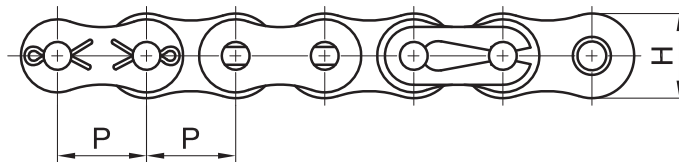
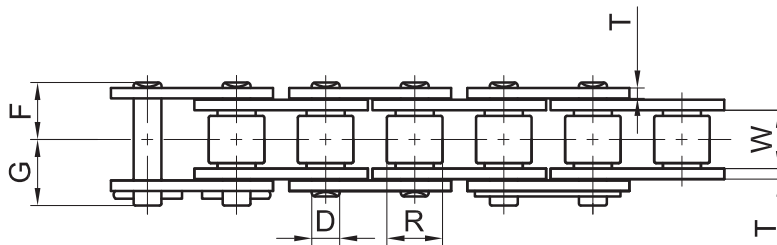

Dimensions: inch

Chain No.	Pitch	Roller		Plate		Pin Dia.	Overall Width		Avg. Ult. Tensile Strength (Lbs.)	Max. Working Load (Lbs.)	Avg. Weight Per Foot (Lbs.)
		Width	Dia.	Height	Thickness		F	G			
	P	W	R	H	T	D	F	G			
25	0.250	0.125	0.130	0.228	0.030	0.091	0.154	0.185	1,036	165	0.087
35	0.375	0.188	0.200	0.356	0.050	0.142	0.232	0.303	2,469	485	0.215
41	0.500	0.250	0.306	0.390	0.050	0.142	0.263	0.334	2,866	529	0.276
40	0.500	0.312	0.312	0.475	0.060	0.157	0.324	0.406	4,188	816	0.417
50	0.625	0.375	0.400	0.594	0.080	0.200	0.400	0.488	6,834	1,400	0.679
60	0.750	0.500	0.469	0.712	0.094	0.235	0.501	0.601	9,259	2,094	0.974
80	1.000	0.625	0.625	0.950	0.125	0.313	0.650	0.803	17,636	3,307	1.714
100	1.250	0.750	0.750	1.187	0.156	0.376	0.781	0.950	25,353	5,071	2.654
120	1.500	1.000	0.875	1.425	0.187	0.437	1.005	1.174	34,392	6,834	3.790
140	1.750	1.000	1.000	1.662	0.219	0.500	1.074	1.267	46,297	9,039	4.959
160	2.000	1.250	1.125	1.900	0.250	0.563	1.290	1.459	57,761	11,905	6.317
180	2.250	1.406	1.406	2.137	0.281	0.687	1.443	1.659	84,217	13,669	8.514
200	2.500	1.500	1.562	2.375	0.312	0.781	1.589	1.825	109,129	16,094	10.684
240	3.000	1.875	1.875	2.850	0.375	0.937	1.943	2.179	154,324	29,762	16.396

ANSI/ASME STANDARD

ANSI/ASME HEAVY

DOUBLE PITCH

ISO BRITISH

CORROSION RESISTANT

SELF LUBE

ATTACHMENT CHAIN

SPECIALTY CHAIN

LEAF CHAIN

ANSI/ASME STANDARD ROLLER CHAIN DOUBLE STRAND



1. Our PEER Chain precision roller chains are manufactured to **exceed ANSI/ASME B29.1** requirements.
2. All chain components are **heat-treated** to achieve maximum strength and greater wear resistance.
3. All PEER roller chain is **pre-loaded** during the manufacturing process to minimize initial elongation.
4. **Hot-dipped lubrication** ensures 100% lubrication of all chain components to extend wear life and reduce maintenance costs.

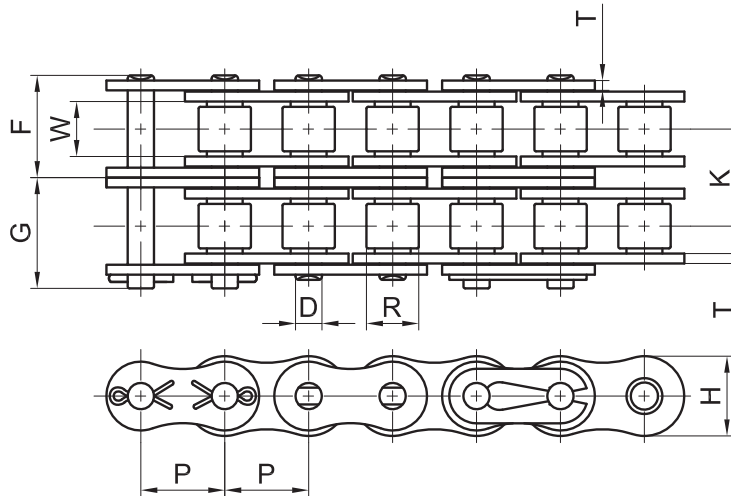

Dimensions: inch

Chain No.	Pitch P	Roller		Plate		Pin Dia. D	Overall Width		Transverse Pitch K	Avg. Ult. Tensile Strength (Lbs.)	Max. Working Load (Lbs.)	Avg. Weight Per Foot (Lbs.)
		Width W	Dia. R	Height H	Thickness T		F	G				
25-2	0.250	0.125	0.130	0.228	0.030	0.091	0.280	0.311	0.252	2,072	287	0.168
35-2	0.375	0.188	0.200	0.356	0.050	0.142	0.441	0.496	0.399	4,938	827	0.423
40-2	0.500	0.312	0.312	0.475	0.060	0.157	0.608	0.690	0.566	8,378	1,389	0.820
50-2	0.625	0.375	0.400	0.594	0.080	0.200	0.755	0.850	0.713	13,669	2,381	1.344
60-2	0.750	0.500	0.469	0.712	0.094	0.235	0.949	1.055	0.897	18,518	3,571	1.929
80-2	1.000	0.625	0.625	0.950	0.125	0.313	1.224	1.386	1.153	35,273	5,622	3.393
100-2	1.250	0.750	0.750	1.187	0.156	0.376	1.502	1.655	1.408	50,706	8,620	5.282
120-2	1.500	1.000	0.875	1.425	0.187	0.437	1.895	2.060	1.789	68,784	11,618	7.526
140-2	1.750	1.000	1.000	1.662	0.219	0.500	2.030	2.243	1.924	92,594	15,432	9.851
160-2	2.000	1.250	1.125	1.900	0.250	0.563	2.457	2.567	2.305	115,522	20,283	12.526
180-2	2.250	1.406	1.406	2.137	0.281	0.687	2.739	2.955	2.592	168,433	23,149	16.893
200-2	2.500	1.500	1.562	2.375	0.312	0.781	2.998	3.234	2.817	218,258	27,337	21.234
240-2	3.000	1.875	1.875	2.850	0.375	0.937	3.673	3.906	3.458	308,647	50,706	32.523

ANSI/ASME STANDARD ROLLER CHAIN TRIPLE STRAND



1. Our PEER Chain precision roller chains are manufactured to **exceed ANSI/ASME B29.1** requirements.
2. All chain components are **heat-treated** to achieve maximum strength and greater wear resistance.
3. All PEER roller chain is **pre-loaded** during the manufacturing process to minimize initial elongation.
4. **Hot-dipped lubrication** ensures 100% lubrication of all chain components to extend wear life and reduce maintenance costs.

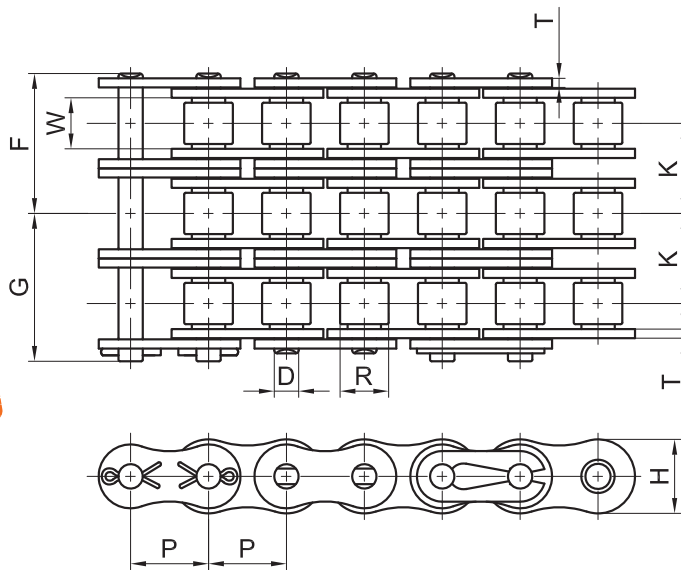

Dimensions: inch



Chain No.	Pitch P	Roller		Plate		Pin Dia. D	Overall Width		Transverse Pitch K	Avg. Ult. Tensile Strength (Lbs.)	Max. Working Load (Lbs.)	Avg. Weight Per Foot (Lbs.)
		Width W	Dia. R	Height H	Thickness T		F	G				
25-3	0.250	0.125	0.130	0.228	0.030	0.091	0.415	0.446	0.252	3,109	408	0.249
35-3	0.375	0.188	0.200	0.356	0.050	0.142	0.633	0.704	0.399	7,408	1,213	0.631
40-3	0.500	0.312	0.312	0.475	0.060	0.157	0.890	0.975	0.566	12,566	2,039	1.223
50-3	0.625	0.375	0.400	0.594	0.080	0.200	1.113	1.222	0.713	20,503	3,505	2.002
60-3	0.750	0.500	0.469	0.712	0.094	0.235	1.400	1.506	0.897	27,778	5,247	2.876
80-3	1.000	0.625	0.625	0.950	0.125	0.313	1.799	1.965	1.153	52,911	8,267	5.067
100-3	1.250	0.750	0.750	1.187	0.156	0.376	2.224	2.338	1.408	76,059	12,677	7.896
120-3	1.500	1.000	0.875	1.425	0.187	0.437	2.773	2.974	1.789	103,176	17,086	11.242
140-3	1.750	1.000	1.000	1.662	0.219	0.500	2.997	3.194	1.924	138,891	22,597	14.736
160-3	2.000	1.250	1.125	1.900	0.250	0.563	3.613	3.691	2.305	173,283	29,762	18.741
180-3	2.250	1.406	1.406	2.137	0.281	0.687	4.035	4.251	2.592	252,650	34,172	25.266
200-3	2.500	1.500	1.562	2.375	0.312	0.781	4.406	4.642	2.817	327,386	40,234	31.784
240-3	3.000	1.875	1.875	2.850	0.375	0.937	5.402	5.638	3.458	462,971	74,516	48.651

ANSI/ASME STANDARD ROLLER CHAIN QUAD STRAND



1. Our PEER Chain precision roller chains are manufactured to **exceed ANSI/ASME B29.1** requirements.
2. All chain components are **heat-treated** to achieve maximum strength and greater wear resistance.
3. All PEER roller chain is **pre-loaded** during the manufacturing process to minimize initial elongation.
4. **Hot-dipped lubrication** ensures 100% lubrication of all chain components to extend wear life and reduce maintenance costs.

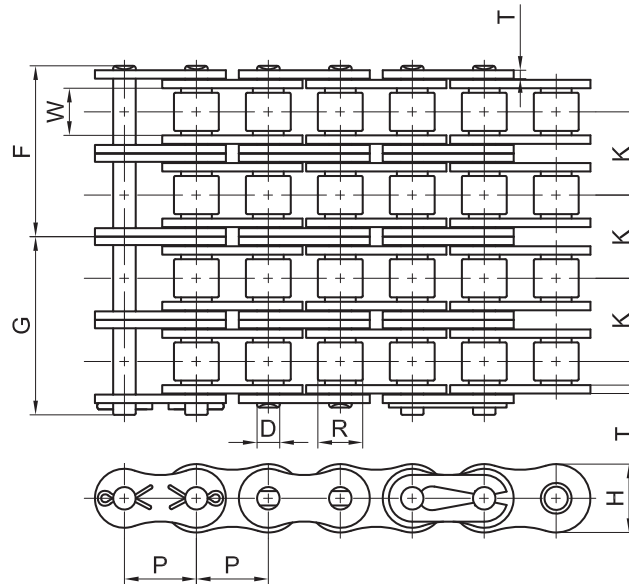

Dimensions: inch

Chain No.	Pitch P	Roller		Plate		Pin Dia. D	Overall Width		Transverse Pitch K	Avg. Ult. Tensile Strength (Lbs.)	Max. Working Load (Lbs.)	Avg. Weight Per Foot (Lbs.)
		Width W	Dia. R	Height H	Thickness T		F	G				
35-4	0.375	0.188	0.200	0.356	0.050	0.142	0.830	0.905	0.399	9,877	1,598	0.840
40-4	0.500	0.312	0.312	0.475	0.060	0.157	1.165	1.268	0.566	17,196	2,690	1.633
50-4	0.625	0.375	0.400	0.594	0.080	0.200	1.483	1.566	0.713	28,440	4,630	2.674
60-4	0.750	0.500	0.469	0.712	0.094	0.235	1.848	1.955	0.897	37,920	6,923	3.830
80-4	1.000	0.625	0.625	0.950	0.125	0.313	2.392	2.526	1.153	70,548	10,913	6.760
100-4	1.250	0.750	0.750	1.187	0.156	0.376	2.909	3.063	1.408	117,506	16,733	10.516
120-4	1.500	1.000	0.875	1.425	0.187	0.437	3.682	3.832	1.789	155,426	22,553	14.971
140-4	1.750	1.000	1.000	1.662	0.219	0.500	3.959	4.152	1.924	213,407	29,762	19.648
160-4	2.000	1.250	1.125	1.900	0.250	0.563	4.746	4.920	2.305	267,200	39,242	25.004
180-4	2.250	1.406	1.406	2.137	0.281	0.687	5.331	5.547	2.592	336,866	45,195	33.639
200-4	2.500	1.500	1.562	2.375	0.312	0.781	5.814	6.050	2.817	436,515	45,195	42.200
240-4	3.000	1.875	1.875	2.850	0.375	0.937	7.130	7.366	3.458	617,294	98,326	64.643

ANSI/ASME STANDARD ROLLER CHAIN 5 STRANDS



1. Our PEER Chain precision roller chains are manufactured to **exceed ANSI/ASME B29.1** requirements.
2. All chain components are **heat-treated** to achieve maximum strength and greater wear resistance.
3. All PEER roller chain is **pre-loaded** during the manufacturing process to minimize initial elongation.
4. **Hot-dipped lubrication** ensures 100% lubrication of all chain components to extend wear life and reduce maintenance costs.

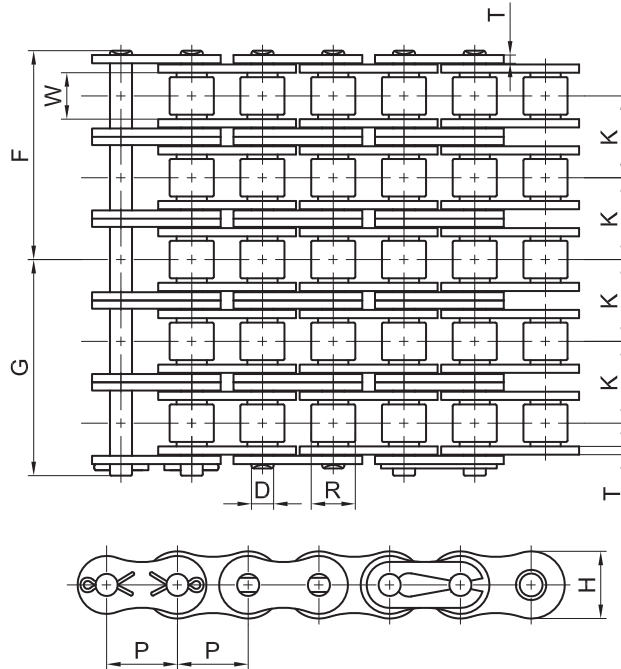

Dimensions: inch

Chain No.	Pitch P	Roller		Plate		Pin Dia. D	Overall Width		Transverse Pitch K	Avg. Ult. Tensile Strength (Lbs.)	Max. Working Load (Lbs.)	Avg. Weight Per Foot (Lbs.)
		Width W	Dia. R	Height H	Thickness T		F	G				
35-5	0.375	0.188	0.200	0.356	0.050	0.142	1.033	1.105	0.399	12,346	1,896	1.408
40-5	0.500	0.312	0.312	0.475	0.060	0.157	1.449	1.552	0.566	21,560	3,186	2.120
50-5	0.625	0.375	0.400	0.594	0.080	0.200	1.840	1.923	0.713	35,494	5,467	3.420
60-5	0.750	0.500	0.469	0.712	0.094	0.235	2.284	2.411	0.897	47,399	8,157	4.970
80-5	1.000	0.625	0.625	0.950	0.125	0.313	2.957	3.122	1.153	88,185	12,897	8.480
100-5	1.250	0.750	0.750	1.187	0.156	0.376	3.610	3.751	1.408	146,828	19,775	13.960
120-5	1.500	1.000	0.875	1.425	0.187	0.437	4.574	4.763	1.789	194,448	26,654	19.870
140-5	1.750	1.000	1.000	1.662	0.219	0.500	4.922	5.146	1.924	266,759	35,274	26.090
160-5	2.000	1.250	1.125	1.900	0.250	0.563	5.190	6.781	2.305	334,000	46,297	33.190
240-5	3.000	1.875	1.875	2.850	0.375	0.937	8.858	9.094	3.458	771,618	116,184	85.700



ANSI/ASME STANDARD ROLLER CHAIN 6 STRANDS



1. Our PEER Chain precision roller chains are manufactured to **exceed ANSI/ASME B29.1** requirements.
2. All chain components are **heat-treated** to achieve maximum strength and greater wear resistance.
3. All PEER roller chain is **pre-loaded** during the manufacturing process to minimize initial elongation.
4. **Hot-dipped lubrication** ensures 100% lubrication of all chain components to extend wear life and reduce maintenance costs.

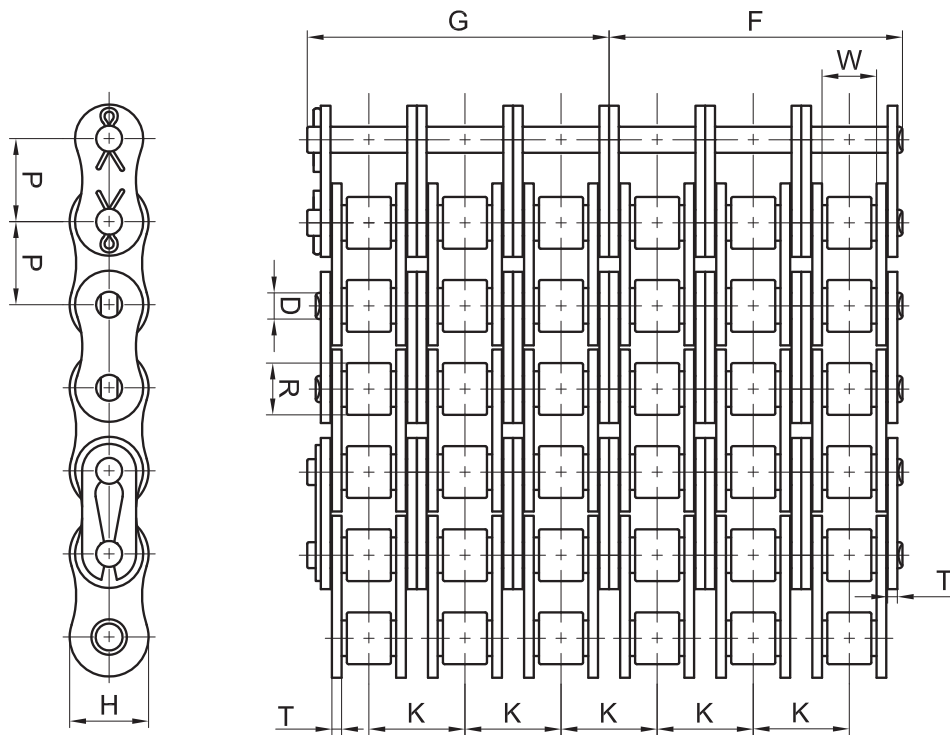

Dimensions: inch

Chain No.	Pitch P	Roller		Plate		Pin Dia. D	Overall Width		Transverse Pitch K	Avg. Ult. Tensile Strength (Lbs.)	Max. Working Load (Lbs.)	Avg. Weight Per Foot (Lbs.)
		Width W	Dia. R	Height H	Thickness T		F	G				
40-6	0.500	0.312	0.312	0.475	0.060	0.157	1.738	1.833	0.566	25,794	3,748	2.610
50-6	0.625	0.375	0.400	0.594	0.080	0.200	2.187	2.272	0.713	42,770	6,424	4.310
60-6	0.750	0.500	0.469	0.712	0.094	0.235	2.746	2.846	0.897	56,879	9,634	6.090
80-6	1.000	0.625	0.625	0.950	0.125	0.313	3.534	3.666	1.153	105,822	15,212	10.850
100-6	1.250	0.750	0.750	1.187	0.156	0.376	4.314	4.444	1.408	176,370	23,325	16.750
120-6	1.500	1.000	0.875	1.425	0.187	0.437	5.468	5.633	1.789	233,249	31,438	23.910
140-6	1.750	1.000	1.000	1.662	0.219	0.500	5.883	6.077	1.924	320,111	41,667	31.290
160-6	2.000	1.250	1.125	1.900	0.250	0.563	6.343	9.084	2.305	400,800	54,560	39.790
240-6	3.000	1.875	1.875	2.850	0.375	0.937	10.587	11.039	3.458	925,942	136,907	100.490

ANSI/ASME STANDARD ROLLER CHAIN 8 STRANDS



1. Our PEER Chain precision roller chains are manufactured to **exceed ANSI/ASME B29.1** requirements.
2. All chain components are **heat-treated** to achieve maximum strength and greater wear resistance.
3. All PEER roller chain is **pre-loaded** during the manufacturing process to minimize initial elongation.
4. **Hot dipped lubrication** ensures 100% lubrication of all chain components to extend wear life and reduce maintenance costs.

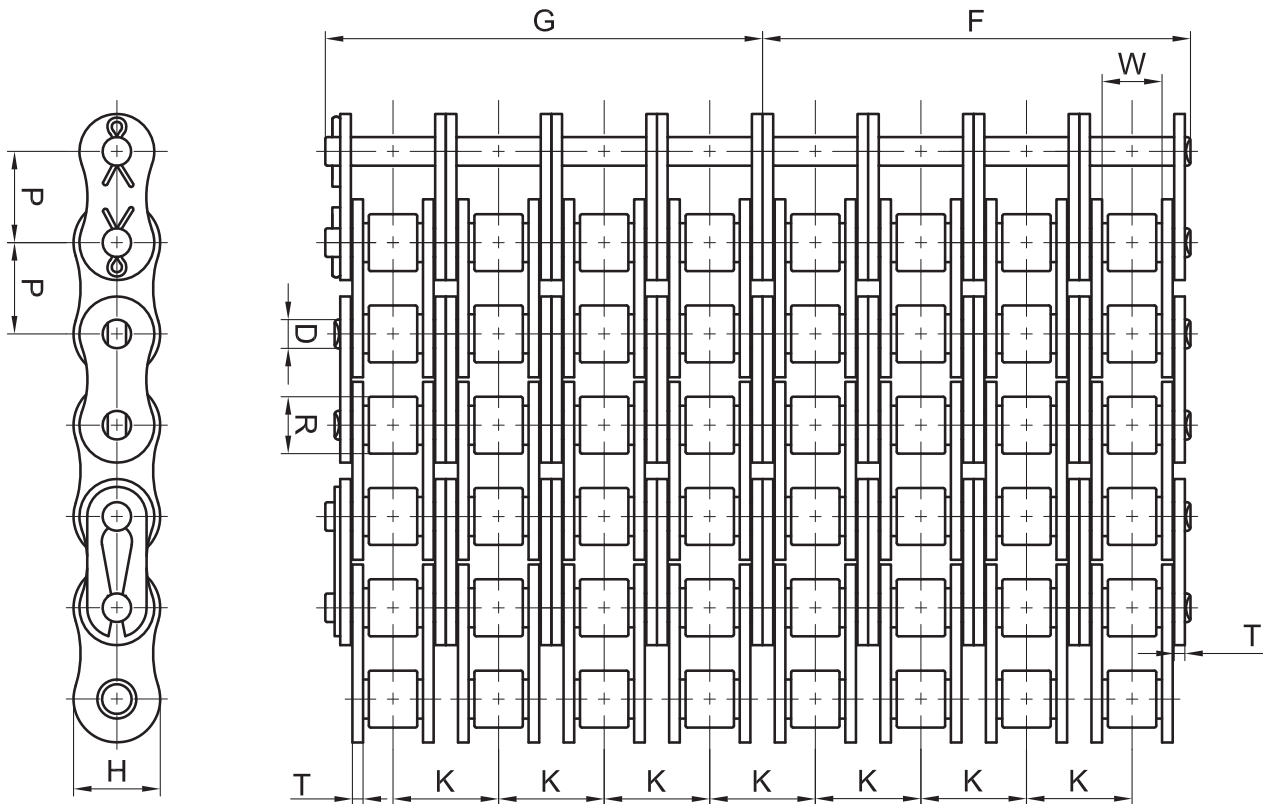

Dimensions: inch

Chain No.	Pitch P	Roller		Plate		Pin Dia. D	Overall Width		Transverse Pitch K	Avg. Ult. Tensile Strength (Lbs.)	Max. Working Load (Lbs.)	Avg. Weight Per Foot (Lbs.)
		Width W	Dia. R	Height H	Thickness T		F	G				
		50-8	0.625	0.375	0.400		0.594	0.080				
60-8	0.750	0.500	0.469	0.712	0.094	0.235	3.642	3.744	0.897	75,839	12,147	8.020
120-8	1.500	1.000	0.875	1.425	0.187	0.437	7.257	7.415	1.789	310,852	39,639	27.290

ANSI/ASME STANDARD C TYPE ROLLER CHAIN SINGLE STRAND



1. Constructed with **straight side plates** rather than peanut-shaped for slightly increased fatigue strength.
2. All chain components are **heat-treated** to achieve maximum strength and greater wear resistance.
3. All PEER roller chain is **pre-loaded** during the manufacturing process to minimize initial elongation.
4. **Hot-dipped lubrication** ensures 100% lubrication of all chain components to extend wear life and reduce maintenance costs.

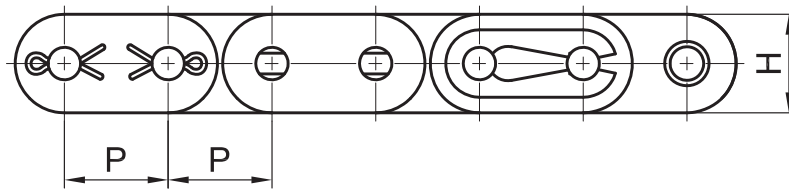
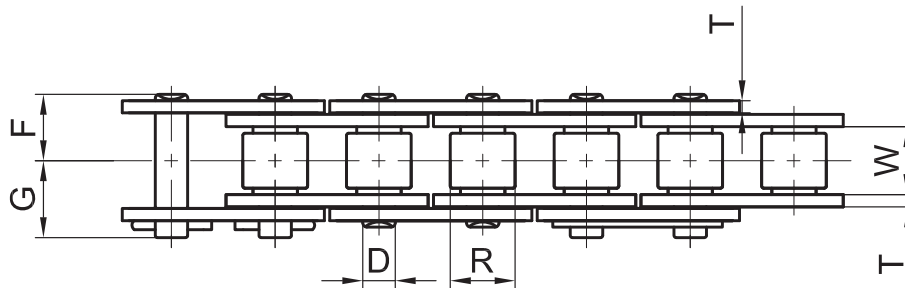

Dimensions: inch

Chain No.	Pitch	Roller		Plate		Pin Dia.	Overall Width		Avg. Ult. Tensile Strength (Lbs.)	Max. Working Load (Lbs.)	Avg. Weight Per Foot (Lbs.)
		Width	Dia.	Height	Thickness		F	G			
	P	W	R	H	T	D	F	G			
C25	0.250	0.125	0.130	0.228	0.030	0.091	0.154	0.185	1,014	150	0.081
C40	0.500	0.312	0.312	0.463	0.060	0.157	0.324	0.406	4,189	620	0.464
C50	0.625	0.375	0.400	0.580	0.080	0.200	0.400	0.488	6,834	1,020	0.726
C60	0.750	0.500	0.469	0.685	0.094	0.235	0.501	0.601	9,259	1,400	1.042
C80	1.000	0.625	0.625	0.950	0.125	0.313	0.650	0.803	17,637	2,700	1.949
C100	1.250	0.750	0.750	1.187	0.156	0.376	0.781	0.950	25,353	4,000	3.037
C120	1.500	1.000	0.875	1.425	0.187	0.437	1.005	1.174	34,392	5,500	4.045
C140	1.750	1.000	1.000	1.662	0.219	0.500	1.074	1.267	46,297	7,100	5.873
C160	2.000	1.250	1.125	1.900	0.250	0.563	1.290	1.459	57,982	9,100	7.277

ANSI/ASME STANDARD C TYPE ROLLER CHAIN DOUBLE STRAND



1. Constructed with **straight side plates** rather than peanut-shaped for slightly increased fatigue strength.
2. All chain components are **heat-treated** to achieve maximum strength and greater wear resistance.
3. All PEER roller chain is **pre-loaded** during the manufacturing process to minimize initial elongation.
4. **Hot-dipped lubrication** ensures 100% lubrication of all chain components to extend wear life and reduce maintenance costs.

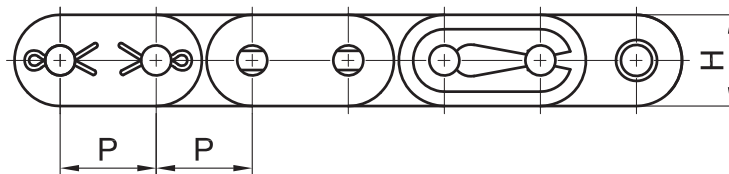
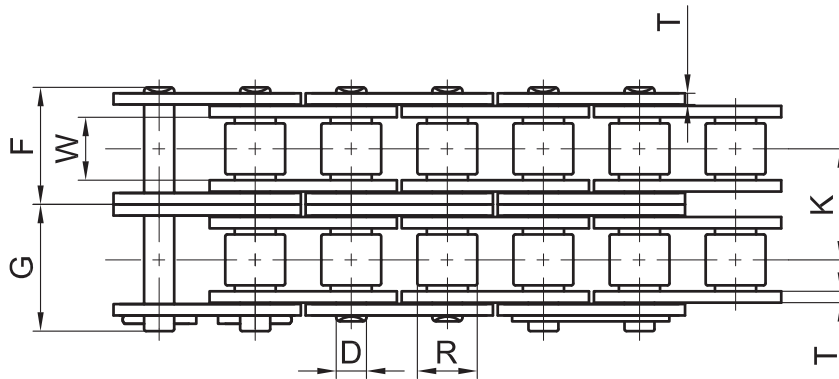

Dimensions: inch

Chain No.	Pitch P	Roller		Plate		Pin Dia. D	Overall Width		Transverse Pitch K	Avg. Ult. Tensile Strength (Lbs.)	Max. Working Load (Lbs.)	Avg. Weight Per Foot (Lbs.)
		Width W	Dia. R	Height H	Thickness T		F	G				
C40-2	0.500	0.312	0.312	0.463	0.060	0.157	0.608	0.690	0.566	8,260	1,239	1.020
C50-2	0.625	0.375	0.400	0.580	0.080	0.200	0.755	0.850	0.713	13,680	2,052	1.730
C60-2	0.750	0.500	0.469	0.685	0.094	0.235	0.949	1.055	0.897	18,440	2,780	2.560
C80-2	1.000	0.625	0.625	0.950	0.125	0.313	1.224	1.386	1.153	35,920	5,390	4.370
C100-2	1.250	0.750	0.750	1.187	0.156	0.376	1.502	1.655	1.408	52,200	7,830	6.490
C120-2	1.500	1.000	0.875	1.425	0.187	0.437	1.895	2.060	1.789	70,400	10,560	9.710
C140-2	1.750	1.000	1.000	1.662	0.219	0.500	2.030	2.243	1.924	94,680	14,202	12.040
C160-2	2.000	1.250	1.125	1.900	0.250	0.563	2.457	2.567	2.305	118,900	17,835	16.360

ANSI/ASME STANDARD C TYPE ROLLER CHAIN TRIPLE STRAND



1. Constructed with **straight side plates** rather than peanut-shaped for slightly increased fatigue strength.
2. All chain components are **heat-treated** to achieve maximum strength and greater wear resistance.
3. All PEER roller chain is **pre-loaded** during the manufacturing process to minimize initial elongation.
4. **Hot dipped lubrication** ensures 100% lubrication of all chain components to extend wear life and reduce chain maintenance costs.

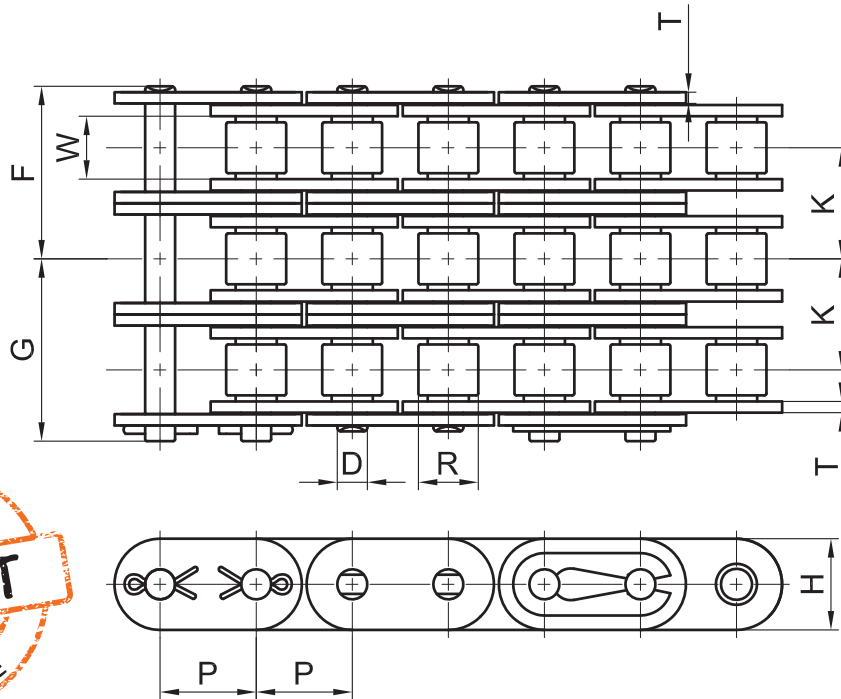

Dimensions: inch

Chain No.	Pitch P	Roller		Plate		Pin Dia. D	Overall Width		Transverse Pitch K	Avg. Ult. Tensile Strength (Lbs.)	Max. Working Load (Lbs.)	Avg. Weight Per Foot (Lbs.)
		Width W	Dia. R	Height H	Thickness T		F	G				
C40-3	0.500	0.312	0.312	0.463	0.060	0.157	0.890	0.975	0.566	11,240	1,650	1.438
C50-3	0.625	0.375	0.400	0.580	0.080	0.200	1.113	1.222	0.713	17,490	2,567	2.433
C60-3	0.750	0.500	0.469	0.685	0.094	0.235	1.400	1.506	0.897	24,976	3,663	3.602
C80-3	1.000	0.625	0.625	0.950	0.125	0.313	1.799	1.965	1.153	44,602	6,547	6.115
C100-3	1.250	0.750	0.750	1.187	0.156	0.376	2.224	2.338	1.408	69,601	10,217	9.139
C120-3	1.500	1.000	0.875	1.425	0.187	0.437	2.773	2.974	1.789	98,286	14,428	13.728
C140-3	1.750	1.000	1.000	1.662	0.219	0.500	2.997	3.194	1.924	133,379	19,579	16.954
C160-3	2.000	1.250	1.125	1.900	0.250	0.563	3.613	3.691	2.305	175,486	25,760	22.975



ANSI/ASME HEAVY

Designed to improve fatigue strength, shock resistance, and greater tensile strength, our PEER Chain heavy series roller chains will keep your operations running. Heavy roller chain is the go-to chain style for demanding applications requiring heavy shock loads, frequent start and stops, or reversing. Heavy series improvements are achieved by increasing link-plate thickness and incorporating through-hardened pins. Additionally, super series chains utilize wider waist plate width and quad-staked pins.

	Heavy H Series	Super S Series	Super Heavy HS Series
Extra link plate thickness	x		x
Wider waist design of link plates		x	x
Through-hardened pins	x	x	x
Solid bushings and rollers		x	x
Heat treatment stability	x	x	x
Shot peened parts		x	x
Chain preloading	x	x	x

Extra link plate thickness

provides greater shock-load resistance and higher ultimate tensile strength

Wider waist design of link plates

ensures greater fatigue strength (maximizes allowable load)

Through-hardened pins

provides greater shock load resistance and higher ultimate tensile strength

Solid bushings and rollers

perfectly cylindrical inside wall reduces stretch and wear during initial operation

Heat treatment stability

heat treatment process control ensures durability and uniformity

Shot peened parts

chain parts are shot-peened for greater fatigue strength

Chain preloading

ensures durability and reduces initial elongation



Sudoku Game

				9			5	1
4				8				
5	1					7		
		2		1	5			
			4		8		3	
	8	6			2			
	9						8	2
	6							
						4	1	

Sudoku Rules:

Every square has to contain a single number

Only the numbers from 1 through 9 can be used

Each 3x3 box can only contain each number from 1 to 9 once

Each vertical column can only contain each number from 1 to 9 once

Each horizontal row can only contain each number from 1 to 9 once

Once the puzzle is solved, this means that every row, column and 3x3 box will contain every number from 1 to 9 exactly once.

**At the beginning of each Escape Room, you will find a puzzle. Solve each puzzle to find the cryptic message in each Escape Room. Once you have completed the puzzles, visit our website (peerchain.com) and search for the discrete door and enter! Once you complete the form, what follows is all about our relationship with you!*

ANSI/ASME STANDARD HEAVY H SERIES SINGLE STRAND



1. Heavy Series chain incorporates **thicker** plates for greater **strength** and **durability**.
2. All chain components are **heat-treated** to achieve maximum strength and greater wear resistance.
3. All PEER roller chain is **pre-loaded** during the manufacturing process to minimize initial elongation.
4. **Hot-dipped lubrication** ensures 100% lubrication of all chain components to extend wear life and reduce maintenance costs.

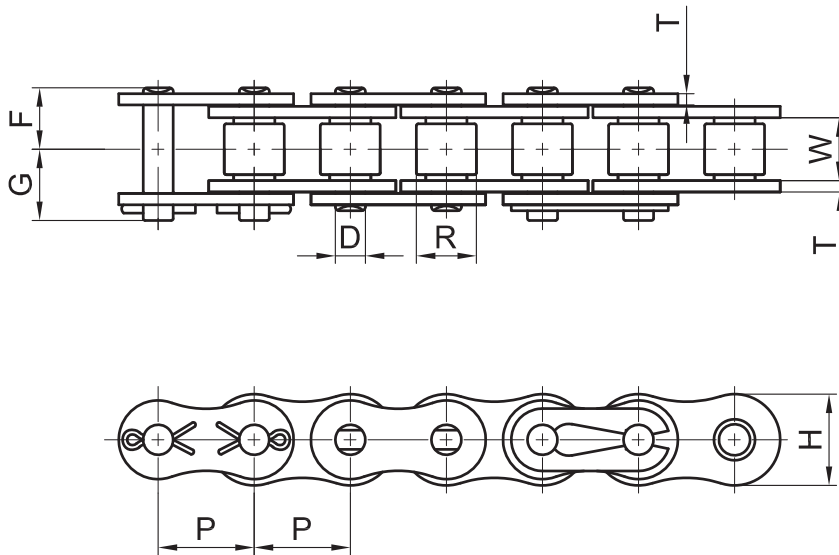

Dimensions: inch

Chain No.	Pitch P	Roller		Plate		Pin Dia. D	Overall Width		Avg. Ult. Tensile Strength (Lbs.)	Max. Working Load (Lbs.)	Avg. Weight Per Foot (Lbs.)
		Width W	Dia. R	Height H	Thickness T		F	G			
25H	0.250	0.125	0.130	0.207	0.040	0.091	0.174	0.603	1,146	170	0.107
40H	0.500	0.312	0.312	0.480	0.080	0.157	0.361	0.456	5,401	809	0.497
50H	0.625	0.375	0.400	0.573	0.094	0.200	0.435	0.526	8,157	1,224	0.766
60H	0.750	0.500	0.469	0.765	0.125	0.235	0.567	0.665	11,905	2,157	1.162
80H	1.000	0.625	0.625	0.956	0.156	0.313	0.715	0.888	21,494	3,564	1.995
100H	1.250	0.750	0.750	1.146	0.187	0.376	0.860	0.998	30,424	5,544	3.017
120H	1.500	1.000	0.875	1.464	0.219	0.437	1.072	1.265	41,447	6,897	4.206
140H	1.750	1.000	1.000	1.530	0.250	0.500	1.144	1.345	54,895	9,500	5.476
160H	2.000	1.250	1.125	1.846	0.281	0.563	1.339	1.546	68,784	11,020	7.109
180H	2.250	1.406	1.406	2.067	0.312	0.687	1.521	1.738	97,444	15,099	9.206
200H	2.500	1.500	1.562	2.295	0.375	0.781	1.715	1.934	113,758	17,558	12.834
240H	3.000	1.875	1.875	2.935	0.500	0.937	2.156	2.533	210,541	25,211	19.856

ANSI/ASME STANDARD HEAVY H SERIES DOUBLE STRAND



1. Heavy Series chain incorporates **thicker** plates for greater **strength** and **durability**.
2. All chain components are **heat-treated** to achieve maximum strength and greater wear resistance.
3. All PEER roller chain is **pre-loaded** during the manufacturing process to minimize initial elongation.
4. **Hot-dipped lubrication** ensures 100% lubrication of all chain components to extend wear life and reduce maintenance costs.

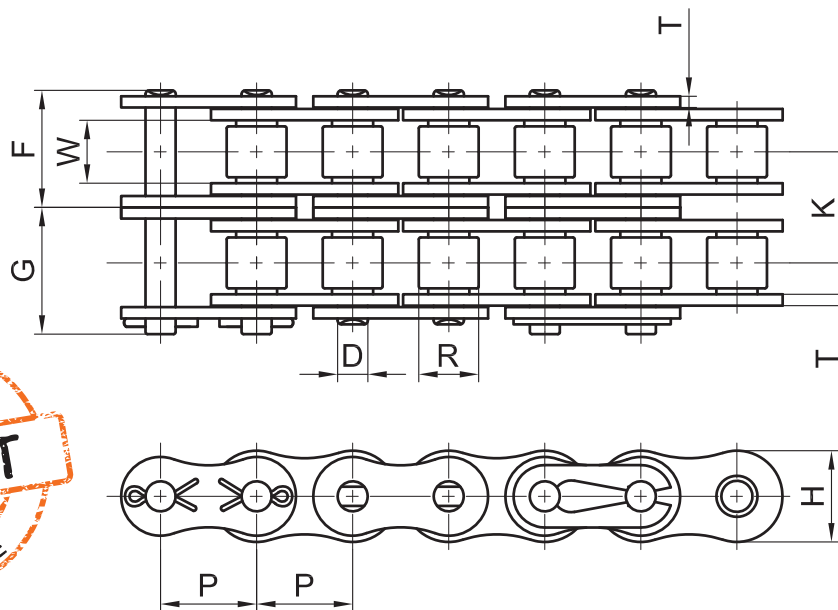

Dimensions: inch

Chain No.	Pitch P	Roller		Plate		Pin Dia. D	Overall Width		Avg. Ult. Tensile Strength (Lbs.)	Max. Working Load (Lbs.)	Avg. Weight Per Foot (Lbs.)
		Width W	Dia. R	Height H	Thickness T		F	G			
25H	0.250	0.125	0.130	0.207	0.040	0.091	0.174	0.603	1,146	170	0.107
40H	0.500	0.312	0.312	0.480	0.080	0.157	0.361	0.456	5,401	809	0.497
50H	0.625	0.375	0.400	0.573	0.094	0.200	0.435	0.526	8,157	1,224	0.766
60H	0.750	0.500	0.469	0.765	0.125	0.235	0.567	0.665	11,905	2,157	1.162
80H	1.000	0.625	0.625	0.956	0.156	0.313	0.715	0.888	21,494	3,564	1.995
100H	1.250	0.750	0.750	1.146	0.187	0.376	0.860	0.998	30,424	5,544	3.017
120H	1.500	1.000	0.875	1.464	0.219	0.437	1.072	1.265	41,447	6,897	4.206
140H	1.750	1.000	1.000	1.530	0.250	0.500	1.144	1.345	54,895	9,500	5.476
160H	2.000	1.250	1.125	1.846	0.281	0.563	1.339	1.546	68,784	11,020	7.109
180H	2.250	1.406	1.406	2.067	0.312	0.687	1.521	1.738	97,444	15,099	9.206
200H	2.500	1.500	1.562	2.295	0.375	0.781	1.715	1.934	113,758	17,558	12.834
240H	3.000	1.875	1.875	2.935	0.500	0.937	2.156	2.533	210,541	25,211	19.856

ANSI/ASME STANDARD HEAVY H SERIES TRIPLE STRAND



1. Heavy Series chain incorporates **thicker** plates for greater **strength** and **durability**.
2. All chain components are **heat-treated** to achieve maximum strength and greater wear resistance.
3. All PEER roller chain is **pre-loaded** during the manufacturing process to minimize initial elongation.
4. **Hot-dipped lubrication** ensures 100% lubrication of all chain components to extend wear life and reduce maintenance costs.

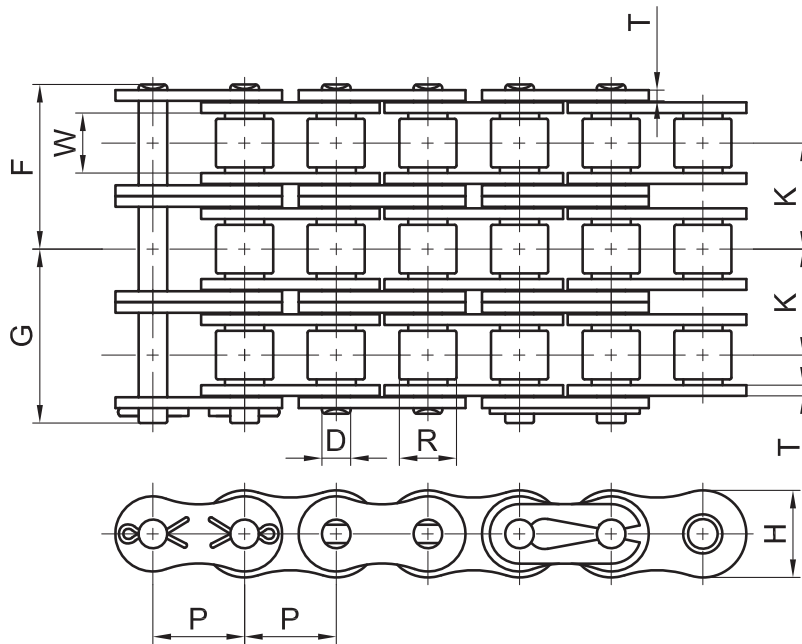

Dimensions: inch

Chain No.	Pitch P	Roller		Plate		Pin Dia. D	Overall Width		Transverse Pitch K	Avg. Ult. Tensile Strength (Lbs.)	Max. Working Load (Lbs.)	Avg. Weight Per Foot (Lbs.)
		Width W	Dia. R	Height H	Thickness T		F	G				
60H-3	0.750	0.500	0.469	0.712	0.125	0.235	1.598	1.685	1.028	35,715	5,445	7.605
80H-3	1.000	0.625	0.625	0.950	0.157	0.313	2.009	2.163	1.283	64,485	8,910	13.066
100H-3	1.250	0.750	0.750	1.187	0.187	0.376	2.407	2.532	1.539	91,271	13,662	19.361
120H-3	1.500	1.000	0.875	1.425	0.219	0.437	3.010	3.195	1.924	124,341	18,612	27.888
140H-3	1.750	1.000	1.000	1.662	0.250	0.500	3.200	3.396	2.055	164,685	23,008	36.088
160H-3	2.000	1.250	1.125	1.900	0.281	0.563	3.776	3.983	2.437	206,352	30,900	46.713
180H-3	2.250	1.406	1.406	2.137	0.312	0.687	4.243	4.707	2.723	292,333	34,470	60.271
200H-3	2.500	1.500	1.562	2.375	0.375	0.781	4.798	5.017	3.083	341,275	43,300	84.379
240H-3	3.000	1.875	1.875	2.850	0.500	0.937	6.141	6.519	3.985	631,624	63,406	128.949

ANSI/ASME STANDARD SUPER S SERIES SINGLE STRAND



1. Super Series chain incorporates **wider waist plates** and **thru-hardened pins** for greater **shock resistance** and **higher working loads**.
2. All chain components are **heat-treated** to achieve maximum strength and greater wear resistance.
3. All PEER roller chain is **pre-loaded** during the manufacturing process to minimize initial elongation.
4. **Hot-dipped lubrication** ensures 100% lubrication of all chain components to extend wear life and reduce maintenance costs.

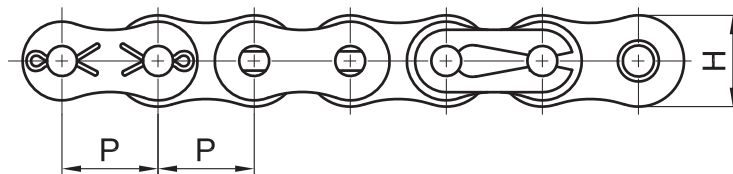
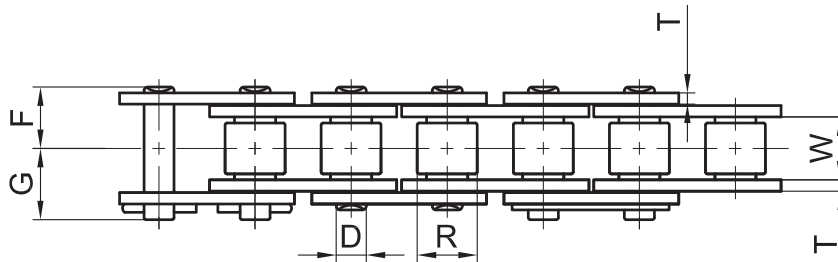

Dimensions: inch

Chain No.	Pitch P	Roller		Plate		Pin Dia. D	Overall Width		Avg. Ult. Tensile Strength (Lbs.)	Max. Working Load (Lbs.)	Avg. Weight Per Foot (Lbs.)
		Width	Dia.	Height	Thickness		F	G			
		W	R	H	T						
40S	0.500	0.312	0.312	0.081	0.060	0.157	0.324	0.406	4,400	924	0.443
50S	0.625	0.375	0.400	0.594	0.080	0.200	0.400	0.488	7,040	1,478	0.726
60S	0.750	0.500	0.469	0.712	0.094	0.235	0.501	0.601	9,680	2,033	1.042
80S	0.100	0.625	0.625	0.950	0.125	0.313	0.650	0.803	18,480	3,881	1.821
100S	1.250	0.750	0.750	1.187	0.156	0.376	0.781	0.950	29,260	6,145	2.762
120S	1.500	1.000	0.875	1.425	0.187	0.437	1.005	1.174	40,480	8,501	4.025
140S	1.750	1.000	1.000	1.662	0.219	0.500	1.091	1.267	53,240	11,180	5.174
160S	2.000	1.250	1.125	1.900	0.250	0.563	1.290	1.459	69,300	14,553	6.511
180S	2.250	1.406	1.406	0.281	0.281	0.687	1.443	1.659	84,040	15,968	8.937
200S	2.500	1.500	1.562	2.375	0.312	0.781	1.589	1.825	110,000	20,900	11.417
240S	3.000	1.875	1.875	2.850	0.375	0.937	1.943	2.179	162,800	29,304	16.396

ANSI/ASME STANDARD SUPER S SERIES DOUBLE STRAND



1. Super Series chain incorporates **wider waist plates** and **thru-hardened pins** for greater **shock resistance** and **higher working loads**.
2. All chain components are **heat-treated** to achieve maximum strength and greater wear resistance.
3. All PEER roller chain is **pre-loaded** during the manufacturing process to minimize initial elongation.
4. **Hot-dipped lubrication** ensures 100% lubrication of all chain components to extend wear life and reduce maintenance costs.

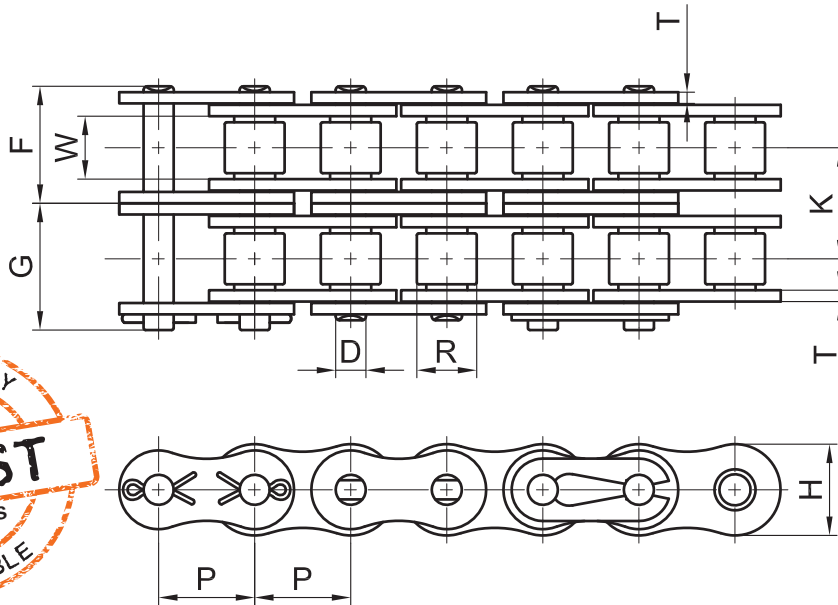

Dimensions: inch

Chain No.	Pitch P	Roller		Plate		Pin Dia. D	Overall Width		Transverse Pitch K	Avg. Ult. Tensile Strength (Lbs.)	Max. Working Load (Lbs.)	Avg. Weight Per Foot (Lbs.)
		Width W	Dia. R	Height H	Thickness T		F	G				
40S-2	0.500	0.312	0.312	0.081	0.060	0.157	0.607	0.689	0.566	8,800	1,584	0.87
50S-2	0.625	0.375	0.400	0.594	0.080	0.200	0.756	0.845	0.713	14,080	2,534	1.53
60S-2	0.750	0.500	0.469	0.712	0.094	0.235	0.949	1.050	0.897	19,360	3,485	2.21
80S-2	0.100	0.625	0.625	0.950	0.125	0.313	1.380	1.226	1.153	36,960	6,653	3.86
100S-2	1.250	0.750	0.750	1.187	0.156	0.376	1.485	1.654	1.408	58,520	10,534	5.82
120S-2	1.500	1.000	0.875	1.425	0.187	0.437	1.900	2.069	1.789	80,960	14,573	8.51
140S-2	1.750	1.000	1.000	1.662	0.219	0.500	2.036	2.229	1.924	106,480	19,166	10.96
160S-2	2.000	1.250	1.125	1.900	0.250	0.563	2.443	2.612	2.305	138,600	24,948	13.74
180S-2	2.250	1.406	1.406	0.281	0.281	0.687	2.739	2.955	2.592	168,080	26,893	18.86
200S-2	2.500	1.500	1.562	2.375	0.312	0.781	2.997	3.233	2.817	220,000	35,200	24.24
240S-2	3.000	1.875	1.875	2.850	0.375	0.937	3.672	3.908	3.458	325,600	50,468	34.57

ANSI/ASME STANDARD SUPER S SERIES TRIPLE STRAND

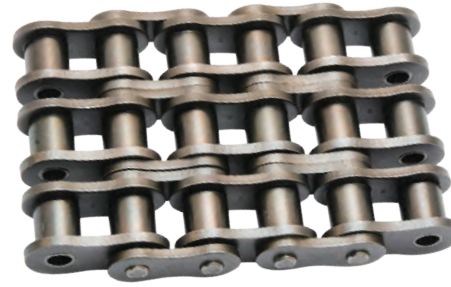

1. Super Series chain incorporates **wider waist plates** and **thru-hardened pins** for greater **shock resistance** and **higher working loads**.
2. All chain components are **heat-treated** to achieve maximum strength and greater wear resistance.
3. All PEER roller chain is **pre-loaded** during the manufacturing process to minimize initial elongation.
4. **Hot-dipped lubrication** ensures 100% lubrication of all chain components to extend wear life and reduce maintenance costs.

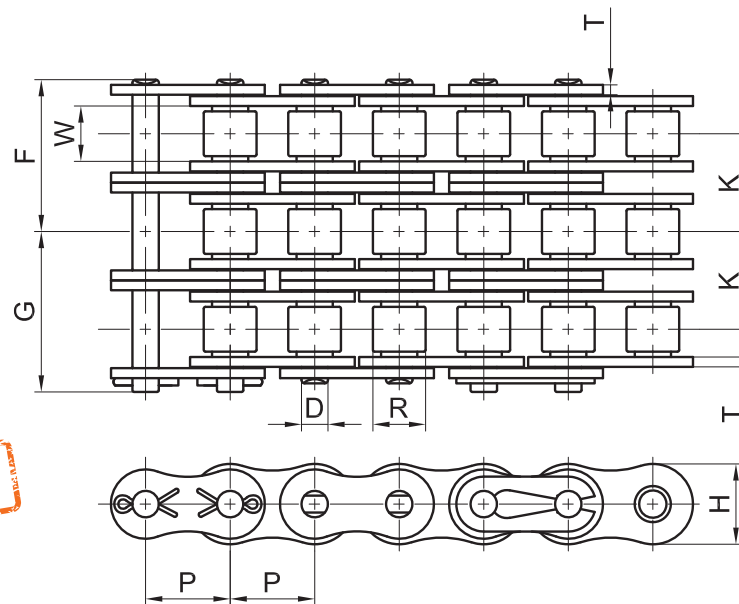

Dimensions: inch

Chain No.	Pitch P	Roller		Plate		Pin Dia. D	Overall Width		Transverse Pitch K	Avg. Ult. Tensile Strength (Lbs.)	Max. Working Load (Lbs.)	Avg. Weight Per Foot (Lbs.)
		Width W	Dia. R	Height H	Thickness T		F	G				
40S-3	0.500	0.375	0.400	0.081	0.060	0.157	0.890	0.972	0.566	13,200	2,442	1.34
50S-3	0.625	0.500	0.469	0.594	0.080	0.200	1.113	1.201	0.713	21,120	3,907	2.30
60S-3	0.750	0.625	0.625	0.712	0.094	0.235	1.398	1.498	0.897	29,040	5,372	3.30
80S-3	0.100	0.750	0.750	0.950	0.125	0.313	1.803	1.956	1.153	55,440	10,256	5.77
100S-3	1.250	1.000	0.875	1.187	0.156	0.376	2.189	2.358	1.408	87,780	16,239	8.72
120S-3	1.500	1.000	1.000	1.425	0.187	0.437	2.794	2.963	1.789	121,440	22,466	12.72
140S-3	1.750	1.250	1.125	1.662	0.219	0.500	2.998	3.191	1.924	159,720	29,548	16.45
160S-3	2.000	1.406	1.406	1.900	0.250	0.563	3.595	3.764	2.305	207,900	38,462	20.56
180S-3	2.250	1.500	1.562	0.281	0.281	0.687	4.035	4.251	2.592	252,120	40,339	28.20
200S-3	2.500	1.875	1.875	2.375	0.312	0.781	4.406	4.642	2.817	330,000	52,800	36.36
240S-3	3.000	0.000	0.000	2.850	0.375	0.937	5.401	5.637	3.458	488,400	73,260	51.71

ANSI/ASME STANDARD SUPER HEAVY HS SERIES SINGLE STRAND



1. Super Heavy chains incorporate the same design features as Super Series plus **thicker link plates** for **superior tensile** and **fatigue strength**.
2. All chain components are **heat-treated** to achieve maximum strength and greater wear resistance.
3. All PEER roller chain is **pre-loaded** during the manufacturing process to minimize initial elongation.
4. **Hot-dipped lubrication** ensures 100% lubrication of all chain components to extend wear life and reduce maintenance costs.

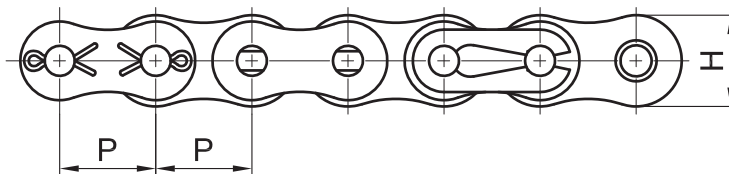
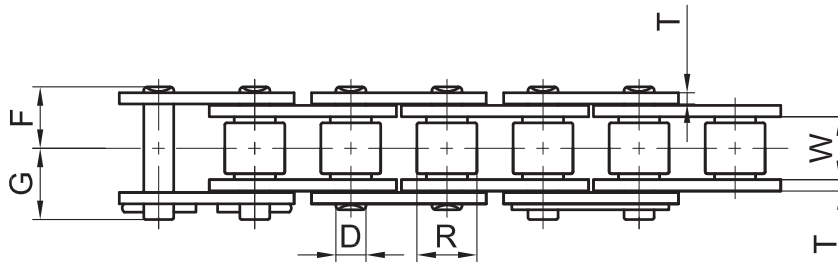

Dimensions: inch

Chain No.	Pitch	Roller		Plate		Pin Dia.	Overall Width		Avg. Ult. Tensile Strength (Lbs.)	Max. Working Load (Lbs.)	Avg. Weight Per Foot (Lbs.)
		Width	Dia.	Height	Thickness		F	G			
	P	W	R	H	T	D	F	G			
50HS	0.625	0.375	0.400	0.594	0.094	0.200	0.435	0.526	8,800	1,760	0.84
60HS	0.750	0.500	0.469	0.712	0.125	0.235	0.567	0.665	12,100	2,420	1.25
80HS	1.000	0.625	0.625	0.950	0.156	0.313	0.715	0.888	21,780	4,350	2.21
100HS	1.250	0.750	0.750	1.187	0.187	0.376	0.860	0.998	30,800	6,160	3.27
120HS	1.500	1.000	0.875	1.425	0.219	0.437	1.072	1.265	42,020	8,820	4.77
140HS	1.750	1.000	1.000	1.662	0.250	0.500	1.144	1.345	54,780	11,500	6.07
160HS	2.000	1.250	1.125	1.900	0.281	0.563	1.339	1.546	71,500	15,000	7.56
180HS	2.250	1.406	1.406	2.137	0.312	0.687	1.521	1.738	97,240	19,500	10.28
200HS	2.500	1.500	1.562	2.375	0.375	0.781	1.715	1.934	113,520	22,150	13.76
240HS	3.000	1.875	1.875	2.850	0.500	0.937	2.156	2.533	210,100	30,500	21.11

ANSI/ASME STANDARD SUPER HEAVY HS SERIES DOUBLE STRAND



1. Super Heavy chains incorporate the same design features as Super Series plus **thicker link plates** for **superior tensile** and **fatigue strength**.
2. All chain components are **heat-treated** to achieve maximum strength and greater wear resistance.
3. All PEER roller chain is **pre-loaded** during the manufacturing process to minimize initial elongation.
4. **Hot dipped-lubrication** ensures 100% lubrication of all chain components to extend wear life and reduce maintenance costs.

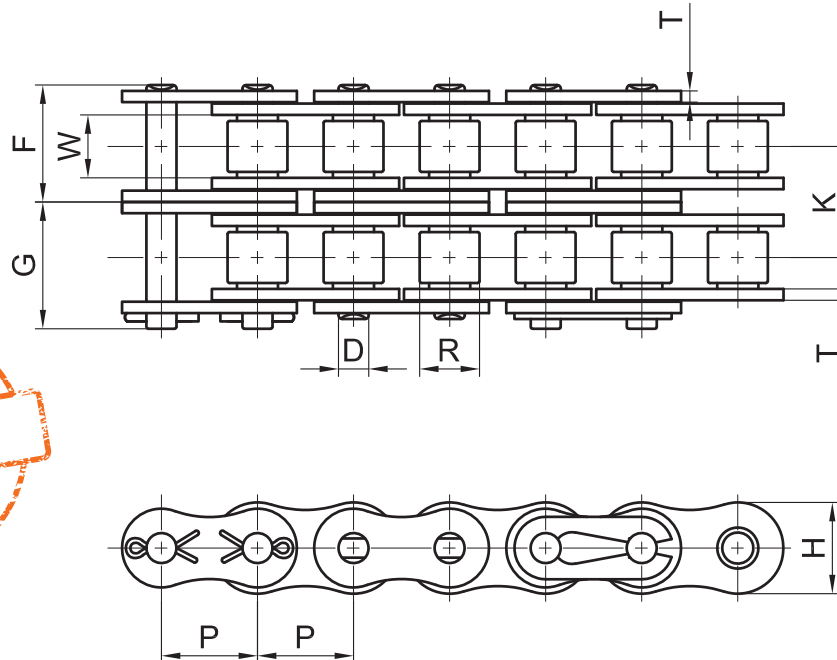

Dimensions: inch

Chain No.	Pitch P	Roller		Plate		Pin Dia. D	Overall Width		Transverse Pitch K	Avg. Ult. Tensile Strength (Lbs.)	Max. Working Load (Lbs.)	Avg. Weight Per Foot (Lbs.)
		Width W	Dia. R	Height H	Thickness T		F	G				
60HS-2	0.750	0.500	0.469	0.712	0.125	0.235	1.081	1.179	1.028	24,200	4,600	2.46
80HS-2	1.000	0.625	0.625	0.950	0.156	0.313	1.356	1.529	1.283	43,560	8,300	4.33
100HS-2	1.250	0.750	0.750	1.187	0.187	0.376	1.629	1.767	1.539	61,600	11,700	6.34
120HS-2	1.500	1.000	0.875	1.425	0.219	0.437	2.034	2.227	1.924	84,040	16,000	9.22
140HS-2	1.750	1.000	1.000	1.662	0.250	0.500	2.172	2.373	2.055	109,560	21,000	11.82
160HS-2	2.000	1.250	1.125	1.900	0.281	0.563	2.557	2.764	2.437	143,000	27,000	15.06
180HS-2	2.250	1.406	1.406	2.137	0.312	0.687	2.883	3.099	2.723	194,480	31,200	20.61
200HS-2	2.500	1.500	1.562	2.375	0.375	0.781	3.257	3.476	0.327	227,040	36,500	27.29
240HS-2	3.000	1.875	1.875	2.850	0.500	0.937	4.148	4.526	3.985	420,200	52,500	41.54

ANSI/ASME STANDARD SUPER HEAVY HS SERIES TRIPLE STRAND

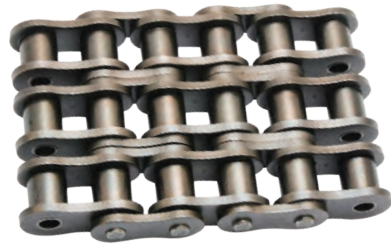

1. Super Heavy chains incorporate the same design features as Super Series plus **thicker link plates** for **superior tensile** and **fatigue strength**.
2. All chain components are **heat-treated** to achieve maximum strength and greater wear resistance.
3. All PEER roller chain is **pre-loaded** during the manufacturing process to minimize initial elongation.
4. **Hot dipped-lubrication** ensures 100% lubrication of all chain components to extend wear life and reduce maintenance costs.

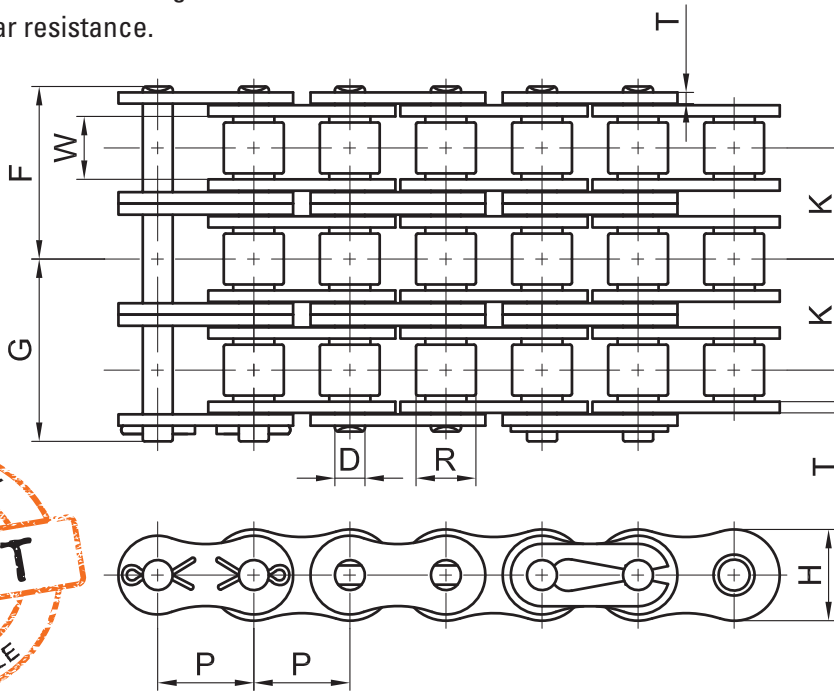

Dimensions: inch

Chain No.	Pitch P	Roller		Plate		Pin Dia. D	Overall Width		Transverse Pitch K	Avg. Ult. Tensile Strength (Lbs.)	Max. Working Load (Lbs.)	Avg. Weight Per Foot (Lbs.)
		Width W	Dia. R	Height H	Thickness T		F	G				
60HS-3	0.750	0.500	0.469	0.712	0.125	0.235	1.595	1.693	1.028	36,300	6,530	3.68
80HS-3	1.000	0.625	0.625	0.950	0.156	0.313	1.998	2.171	1.283	65,340	11,760	6.56
100HS-3	1.250	0.750	0.750	1.187	0.187	0.376	2.399	2.537	1.539	92,400	17,550	9.41
120HS-3	1.500	1.000	0.875	1.425	0.219	0.437	2.996	3.189	1.924	126,060	23,950	14.21
140HS-3	1.750	1.000	1.000	1.662	0.250	0.500	3.200	3.400	2.055	164,340	31,220	17.70
160HS-3	2.000	1.250	1.125	1.900	0.281	0.563	3.776	3.983	2.437	214,500	40,750	22.42
180HS-3	2.250	1.406	1.406	2.137	0.312	0.687	4.244	4.461	2.723	291,720	55,430	31.02
200HS-3	2.500	1.500	1.562	2.375	0.375	0.781	4.798	5.017	3.083	340,560	54,490	40.90
240HS-3	3.000	1.875	1.875	2.850	0.500	0.937	6.141	6.519	3.985	630,300	76,900	61.89

ANSI/ASME STANDARD SUPER HEAVY HS SERIES C TYPE



1. Super Heavy chains incorporate the same design features as Super Series plus **thicker link plates** for **superior tensile** and **fatigue strength**.
2. All chain components are **heat-treated** to achieve maximum strength and greater wear resistance.
3. All PEER roller chain is **pre-loaded** during the manufacturing process to minimize initial elongation.
4. **Hot dipped-lubrication** ensures 100% lubrication of all chain components to extend wear life and reduce maintenance costs.

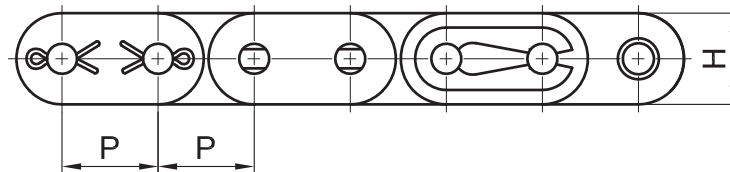
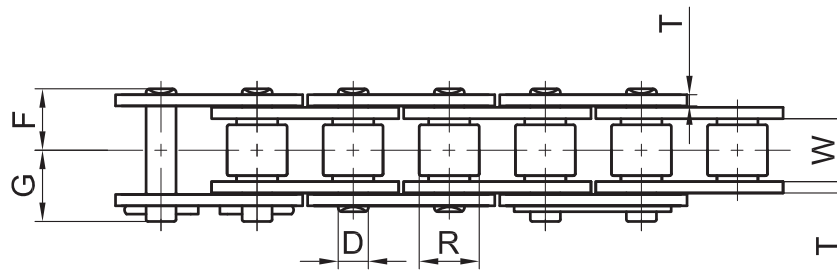

Dimensions: inch

Chain No.	Pitch P	Roller		Plate		Pin Dia. D	Overall Width		Avg. Ult. Tensile Strength (Lbs.)	Max. Working Load (Lbs.)	Avg. Weight Per Foot (Lbs.)
		Width W	Dia. R	Height H	Thickness T		F	G			
C60HS	0.750	0.500	0.469	0.712	0.125	0.235	0.567	0.665	12,540	2,500	1.44
C80HS	1.000	0.625	0.625	0.950	0.156	0.313	0.715	0.888	22,440	4,480	2.31
C100HS	1.250	0.750	0.750	1.187	0.187	0.376	0.860	0.998	32,560	6,500	3.41
C120HS	1.500	1.000	0.875	1.425	0.219	0.437	1.072	1.265	44,000	8,800	4.98
C140HS	1.750	1.000	1.000	1.662	0.250	0.500	1.144	1.345	57,420	11,480	6.37
C160HS	2.000	1.250	1.125	1.900	0.281	0.563	1.339	1.546	72,600	14,520	7.88



DOUBLE PITCH

Our PEER Chain ANSI double pitch roller chains are built with the same precision and quality as single pitch chains, except the pitch is twice as long. Double pitch roller chains are produced in two different styles: the first style "A" is produced with peanut-shape plates and the second "C" style is produced with straight plates. Our PEER Chain double pitch roller chain is an optimum solution for drive applications with low speed and long distance. You can rest assured knowing that all chain components are heat-treated to achieve maximum strength and greater wear resistance. All PEER roller chains are pre-loaded during manufacturing to minimize initial elongation. The hot-dipped lubrication process ensures lubrication of chain components to extend their wear life and reduce maintenance costs.



Word Jumble

**EVRO FYITF
AEYRS FO
OPREMANFECR
LPOEEP
NDA
SNIOSAP!**

**At the beginning of each Escape Room, you will find a puzzle. Solve each puzzle to find the cryptic message in each Escape Room. Once you have completed the puzzles, visit our website (peerchain.com) and search for the discrete door and enter! Once you complete the form, what follows is all about our relationship with you!*

ANSI/ASME STANDARD STANDARD DOUBLE PITCH ROLLER CHAIN AGRICULTURAL A TYPE



1. Designed for **low speed** and long distance **drive applications**.
2. All chain components are **heat-treated** to achieve maximum strength and greater wear resistance.
3. All PEER roller chain is **pre-loaded** during the manufacturing process to minimize initial elongation.
4. **Hot-dipped lubrication** ensures 100% lubrication of all chain components to extend wear life and reduce maintenance costs.

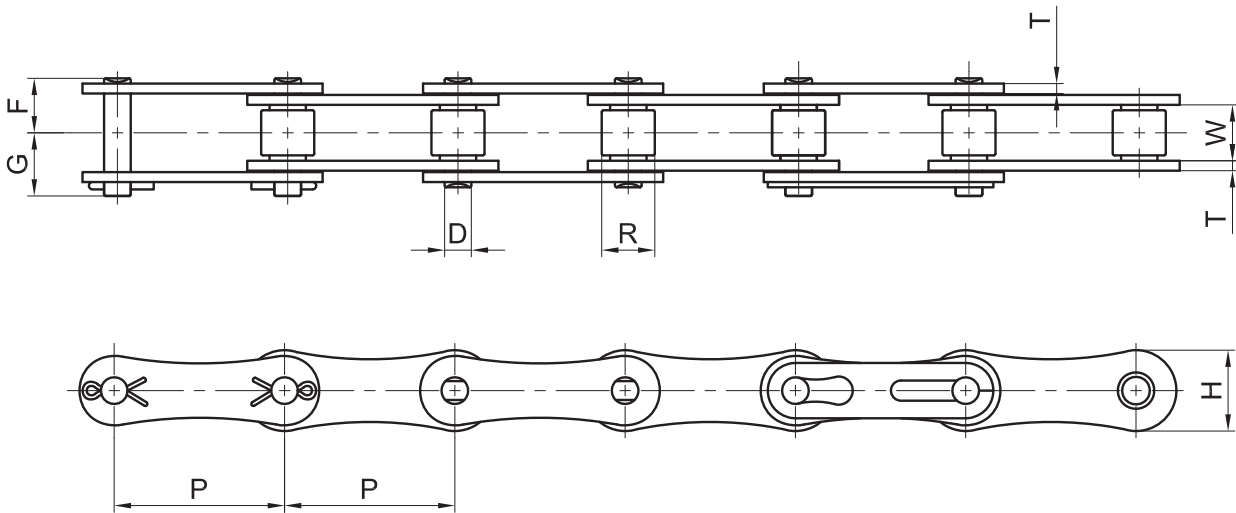

Dimensions: inch

Chain No.	Pitch P	Roller		Plate		Pin Dia. D	Overall Width		Avg. Ult. Tensile Strength (Lbs.)	Max. Working Load (Lbs.)	Avg. Weight Per Foot (Lbs.)
		Width W	Dia. R	Height H	Thickness T		F	G			
A2041	1.000	0.250	0.306	0.390	0.050	0.142	0.263	0.334	2,866	441	0.242
A2040	1.000	0.312	0.312	0.475	0.060	0.157	0.324	0.406	4,189	661	0.276
A2050	1.250	0.375	0.400	0.594	0.080	0.200	0.400	0.488	6,834	990	0.457
A2060	1.500	0.500	0.469	0.712	0.094	0.235	0.501	0.601	9,259	1,430	0.638
A2080	2.000	0.625	0.625	0.950	0.125	0.313	0.650	0.803	17,637	2,420	1.176

ANSI/ASME STANDARD DOUBLE PITCH ROLLER CHAIN AGRICULTURAL A TYPE OVERSIZED ROLLERS

1. Designed for **low speed** and long distance **conveyor applications**.
2. All chain components are **heat-treated** to achieve maximum strength and greater wear resistance.
3. All PEER roller chain is **pre-loaded** during the manufacturing process to minimize initial elongation.
4. **Hot-dipped lubrication** ensures 100% lubrication of all chain components to extend wear life and reduce maintenance costs.

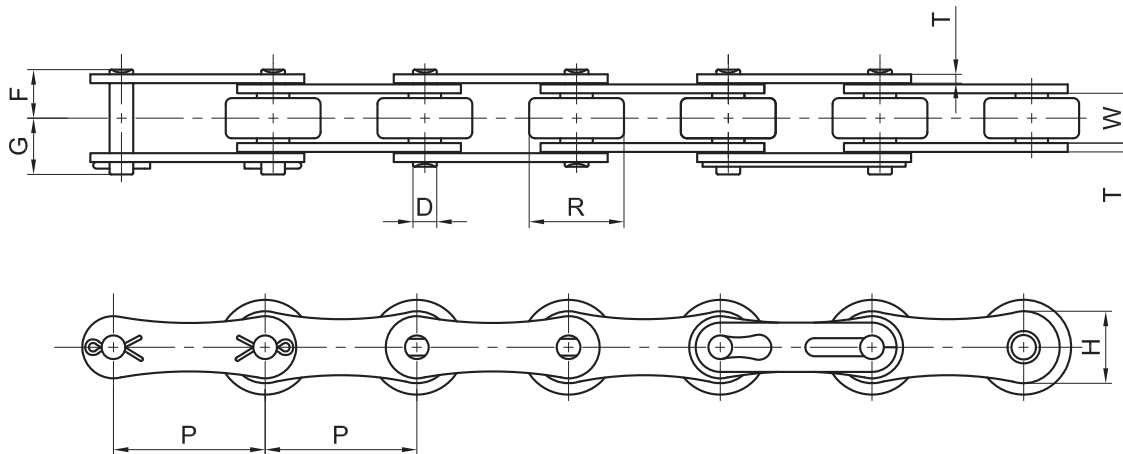

Dimensions: inch

Chain No.	Pitch	Roller		Plate		Pin Dia.	Overall Width		Avg. Ult. Tensile Strength (Lbs.)	Max. Working Load (Lbs.)	Avg. Weight Per Foot (Lbs.)
		Width	Dia.	Height	Thickness		F	G			
	P	W	R	H	T	D	F	G			
A2042	1.000	0.312	0.625	0.475	0.060	0.157	0.324	0.406	4,189	661	0.276
A2052	1.250	0.375	0.750	0.594	0.080	0.200	0.400	0.488	6,834	992	0.457
A2062	1.500	0.500	0.875	0.712	0.094	0.235	0.501	0.601	9,259	1,430	1.115
A2082	2.000	0.625	1.125	0.950	0.125	0.313	0.650	0.803	17,637	2,420	1.176

ANSI/ASME STANDARD DOUBLE PITCH ROLLER CHAIN CONVEYOR C-TYPE



1. Designed for **low speed** and long distance **conveyor applications**.
2. All chain components are **heat-treated** to achieve maximum strength and greater wear resistance.
3. All PEER roller chain is **pre-loaded** during the manufacturing process to minimize initial elongation.
4. **Hot-dipped lubrication** ensures 100% lubrication of all chain components to extend wear life and reduce maintenance costs.

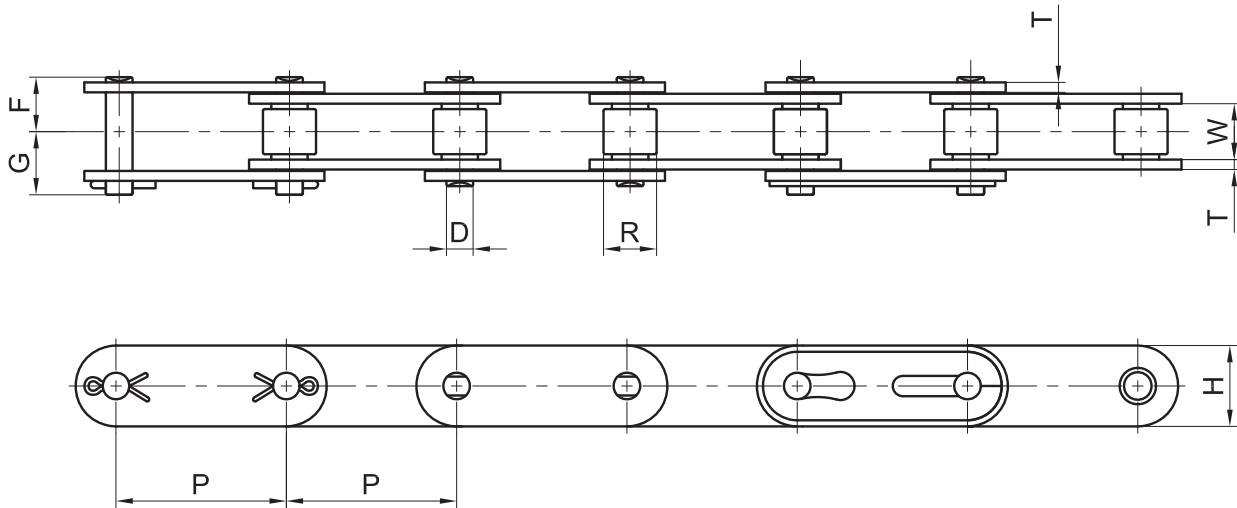

Dimensions: inch

Chain No.	Pitch	Roller		Plate		Pin Dia.	Overall Width		Avg. Ult. Tensile Strength (Lbs.)	Max. Working Load (Lbs.)	Avg. Weight Per Foot (Lbs.)
		Width	Dia.	Height	Thickness		F	G			
	P	W	R	H	T	D	F	G			
C2040	1.000	0.312	0.312	0.475	0.060	0.157	0.324	0.406	4,189	661	0.316
C2050	1.250	0.375	0.400	0.594	0.080	0.200	0.400	0.488	6,834	992	0.538
C2060	1.500	0.500	0.469	0.712	0.094	0.235	0.501	0.601	9,259	1,433	0.759
C2080	2.000	0.625	0.625	0.950	0.125	0.313	0.650	0.803	17,637	2,425	1.337
C2050H	1.250	0.375	0.400	0.594	0.094	0.200	0.435	0.526	7,716	1,102	0.665
C2060H	1.500	0.500	0.469	0.712	0.125	0.235	0.567	0.606	12,125	1,543	0.947
C2080H	2.000	0.625	0.625	0.950	0.156	0.313	0.715	0.888	20,503	2,646	1.599
C2100H	2.500	0.750	0.750	1.187	0.187	0.376	0.860	0.998	30,865	4,079	2.459
C2120H	3.000	1.000	0.875	1.369	0.219	0.437	1.072	1.265	40,345	5,512	3.481
C2160H	4.000	1.250	1.125	1.900	0.281	0.562	1.339	1.546	69,446	9,259	5.745

ANSI/ASME STANDARD DOUBLE PITCH ROLLER CHAIN CONVEYOR C TYPE OVERSIZED ROLLERS



1. Designed for **low speed** and long distance **conveyor applications**.
2. All chain components are **heat-treated** to achieve maximum strength and greater wear resistance.
3. All PEER roller chain is **pre-loaded** during the manufacturing process to minimize initial elongation.
4. **Hot-dipped lubrication** ensures 100% lubrication of all chain components to extend wear life and reduce maintenance costs.

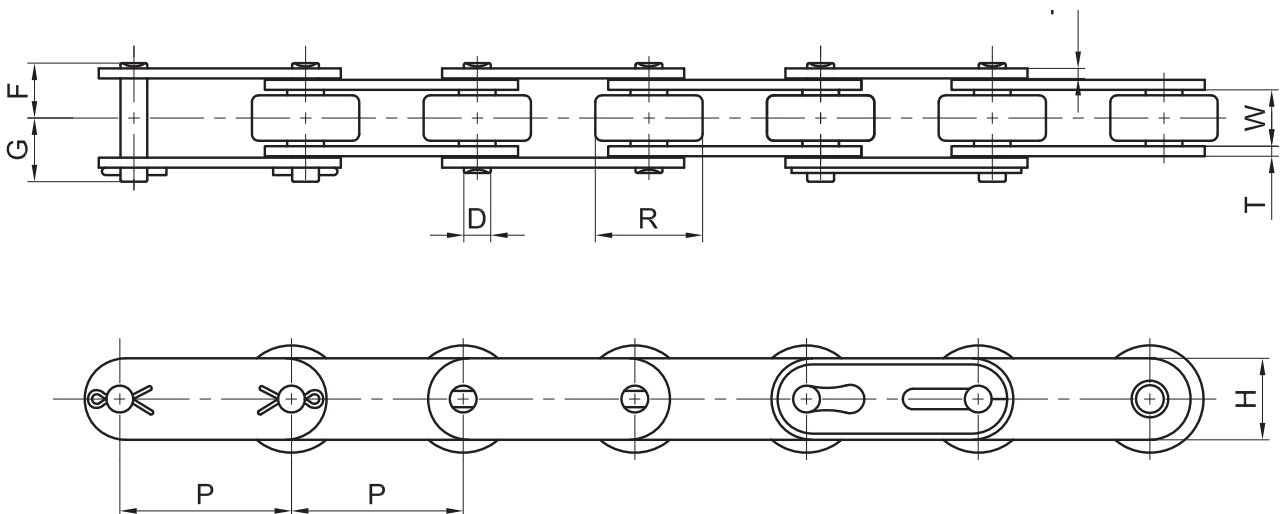

Dimensions: inch

Chain No.	Pitch P	Roller		Plate		Pin Dia. D	Overall Width		Avg. Ult. Tensile Strength (Lbs.)	Max. Working Load (Lbs.)	Avg. Weight Per Foot (Lbs.)
		Width W	Dia. R	Height H	Thickness T		F	G			
		C2042	1.000	0.312	0.625		0.475	0.060			
C2052	1.250	0.375	0.750	0.594	0.080	0.200	0.400	0.488	6,834	992	0.853
C2062	1.500	0.500	0.875	0.712	0.094	0.235	0.501	0.601	9,259	1,433	1.223
C2082	2.000	0.625	1.125	0.950	0.125	0.313	0.650	0.803	17,637	2,425	2.063
C2052H	1.250	0.375	0.750	0.594	0.094	0.200	0.435	0.526	7,716	1,102	0.974
C2062H	1.500	0.500	0.875	0.712	0.125	0.235	0.567	0.606	12,125	1,543	1.431
C2082H	2.000	0.625	1.125	0.950	0.156	0.313	0.715	0.888	20,503	2,646	2.318
C2102H	2.500	0.750	1.562	1.187	0.187	0.376	0.860	0.998	30,865	4,079	3.944
C2122H	3.000	1.000	1.750	1.369	0.219	0.437	1.072	1.265	40,345	5,512	5.436
C2162H	4.000	1.250	2.250	1.900	0.281	0.562	1.339	1.546	69,446	9,259	8.729

ANSI/ASME STANDARD DOUBLE PITCH ROLLER CHAIN DELRIN ROLLERS



1. Designed for **low speed** and long distance **conveyor applications**.
2. All chain components are **heat-treated** to achieve maximum strength and greater wear resistance.
3. All PEER roller chain is **pre-loaded** during the manufacturing process to minimize initial elongation.
4. **Hot-dipped lubrication** ensures 100% lubrication of all chain components to extend wear life and reduce maintenance costs.

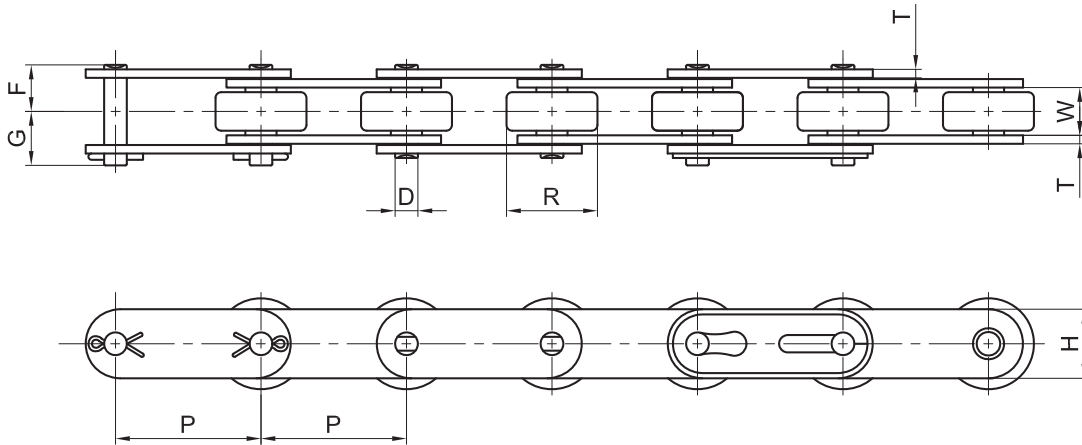

Dimensions: inch

Chain No.	Pitch	Roller		Plate		Pin Dia.	Overall Width		Avg. Ult. Tensile Strength (Lbs.)	Max. Working Load (Lbs.)	Avg. Weight Per Foot (Lbs.)
		Width	Dia.	Height	Thickness		F	G			
	P	W	R	H	T	D	F	G			
A2042	1.000	0.312	0.625	0.475	0.060	0.157	0.324	0.406	4,189	661	0.276
C2042	1.000	0.312	0.625	0.475	0.060	0.157	0.324	0.406	4,189	661	0.558
A2052	1.250	0.375	0.750	0.594	0.080	0.200	0.400	0.488	6,834	992	0.457
C2052	1.250	0.375	0.750	0.594	0.080	0.200	0.400	0.488	6,834	992	0.853
C2052H	1.250	0.375	0.750	0.594	0.094	0.200	0.435	0.526	7,716	1,102	1.450
A2062	1.500	0.500	0.875	0.712	0.094	0.235	0.501	0.601	9,259	1,433	1.115
C2062	1.500	0.500	0.875	0.712	0.094	0.235	0.567	0.601	9,259	1,433	1.223
C2062H	1.500	0.500	0.875	0.712	0.125	0.235	0.567	0.606	12,125	1,433	1.431
A2082	2.000	0.625	1.125	0.950	0.125	0.313	0.650	0.803	17,637	2,425	1.176
C2082	2.000	0.625	1.125	0.950	0.125	0.313	0.715	0.803	17,637	2,425	2.063
C2082H	2.000	0.625	1.125	0.950	0.156	0.313	0.715	0.888	20,503	2,646	2.318
C2102H	2.500	0.750	1.750	1.187	0.187	0.376	0.860	0.998	30,865	4,079	3.944
C2122H	3.000	1.000	1.750	1.369	0.219	0.437	1.072	1.265	40,345	5,512	5.436
C2162H	4.000	1.250	2.250	1.900	0.281	0.562	1.339	1.546	69,446	9,259	8.729

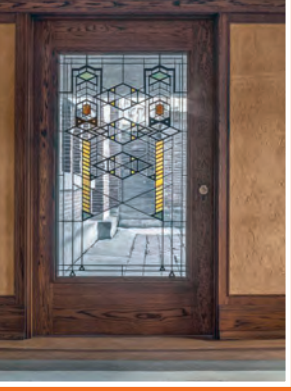

ISO BRITISH

Metric roller chain, also known as ISO British roller chain, is engineered to different specifications than ANSI/ASME Standard roller chain. While the materials and manufacturing processes are often very similar to the ANSI/ASME Standards, the designation, dimensions, and load ratings are slightly different. Our PEER Chain ISO British roller chain is manufactured to meet or exceed ISO, DIN, and BS requirements. For equipment purchased or manufactured internationally, ISO British Standard roller chain is commonly used in place of ANSI/ASME roller chain. Having the right chain for your application is critical, and the PEER Chain team is here to help with any questions.



Morse Code

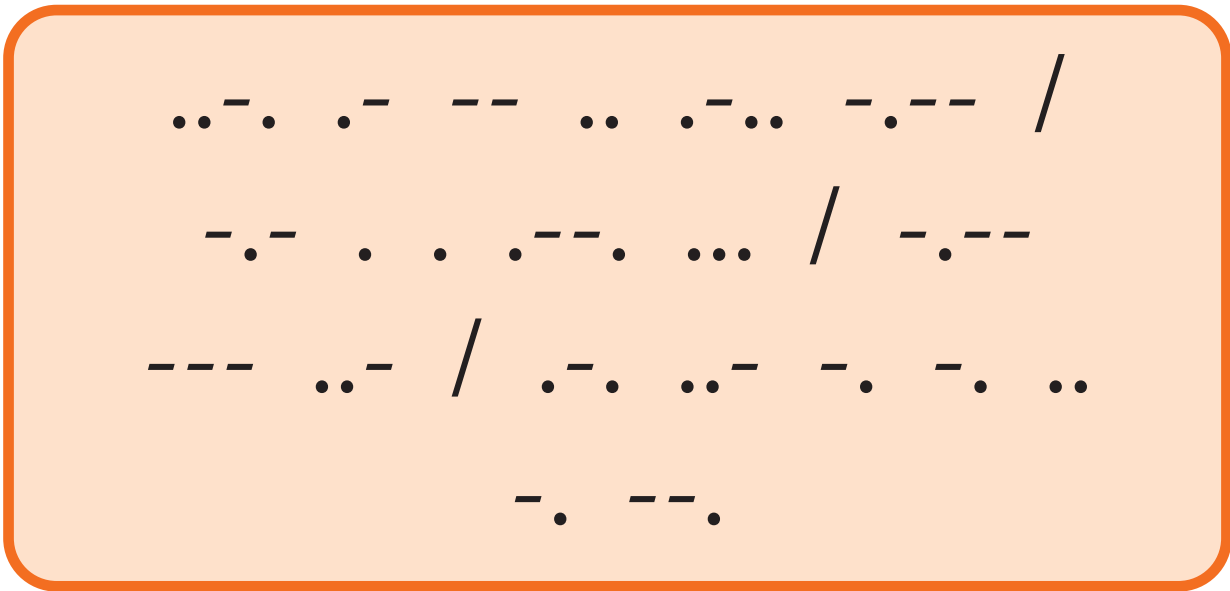

International Morse Code

1. The length of a dot is one unit.
2. A dash is three units.
3. The space between parts of the same letter is one unit.
4. The space between letters is three units
5. The space between words is seven units.

A	● ■■	U	● ● ■■
B	■■■ ● ● ●	V	● ● ● ■■
C	■■■ ● ■■ ●	W	● ■■ ■■
D	■■■ ● ●	X	■■■ ● ● ■■
E	●	Y	■■■ ● ■■ ■■
F	● ● ■■ ●	Z	■■■ ■■ ● ●
G	■■■ ■■ ●		
H	● ● ● ●		
I	● ●		
J	● ■■ ■■ ■■		
K	■■■ ● ■■	1	● ■■ ■■ ■■ ■■
L	● ■■ ● ●	2	● ● ■■ ■■ ■■
M	■■■ ■■	3	● ● ● ■■ ■■
N	■■■ ●	4	● ● ● ● ■■
O	■■■ ■■ ■■	5	● ● ● ● ●
P	● ■■ ■■ ●	6	■■■ ● ● ● ●
Q	■■■ ■■ ● ■■	7	■■■ ■■ ● ● ●
R	● ■■ ■■ ●	8	■■■ ■■ ■■ ● ●
S	● ● ●	9	■■■ ■■ ■■ ■■ ●
T	■■■	0	■■■ ■■ ■■ ■■ ■■

**At the beginning of each Escape Room, you will find a puzzle. Solve each puzzle to find the cryptic message in each Escape Room. Once you have completed the puzzles, visit our website (peerchain.com) and search for the discrete door and enter! Once you complete the form, what follows is all about our relationship with you!*

ISO BRITISH METRIC STANDARD ROLLER CHAIN SINGLE STRAND



1. Our PEER Chain precision roller chains are manufactured to **exceed ISO606** requirements.
2. All chain components are **heat-treated** to achieve maximum strength and greater wear resistance.
3. All PEER roller chain is **pre-loaded** during the manufacturing process to minimize initial elongation.
4. **Hot-dipped lubrication** ensures 100% lubrication of all chain components to extend wear life and reduce maintenance costs.

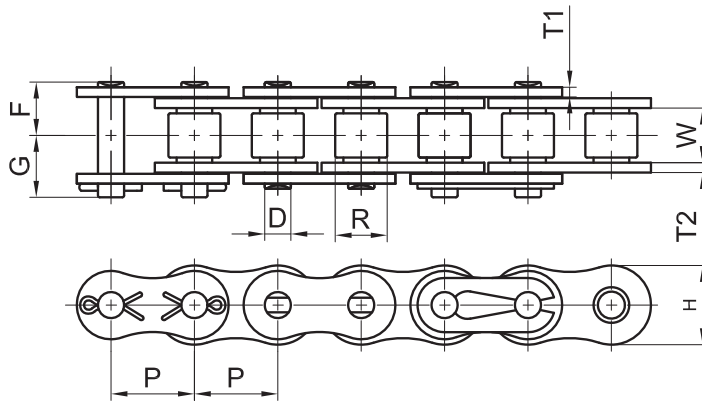

Dimensions: inch

Chain No.	Pitch P	Roller		Plate			Pin Dia. D	Overall Width		Avg. Ult. Tensile Strength (Lbs.)	Max. Working Load (Lbs.)	Avg. Weight Per Foot (Lbs.)
		Width W	Dia. R	Height H	Thickness			F	G			
04B	0.236	0.110	0.157	0.197	0.024	0.024	0.073	0.132	0.175	728	132	0.087
05B	0.315	0.118	0.197	0.280	0.031	0.031	0.091	0.154	0.185	1,280	243	0.108
06B*	0.375	0.225	0.250	0.325	0.039	0.050	0.129	0.241	0.279	2,383	397	0.276
08B	0.500	0.305	0.335	0.465	0.059	0.062	0.175	0.324	0.368	4,236	883	0.443
083	0.500	0.192	0.305	0.406	0.050	0.050	0.161	0.254	0.274	3,310	552	0.282
10B	0.625	0.380	0.400	0.580	0.067	0.067	0.200	0.388	0.455	6,001	1,103	0.618
12B	0.750	0.460	0.475	0.635	0.073	0.073	0.225	0.444	0.574	7,237	1,544	0.813
16B	1.000	0.670	0.625	0.830	0.125	0.157	0.326	0.713	0.831	17,122	3,530	1.787
20B	1.250	0.770	0.750	1.040	0.125	0.176	0.401	0.791	0.961	23,167	4,192	2.433
24B	1.500	1.000	1.000	1.315	0.189	0.236	0.576	1.066	1.267	39,716	7,061	4.737
28B	1.750	1.220	1.100	1.460	0.236	0.287	0.626	1.297	1.474	57,367	9,929	6.437
32B	2.000	1.220	1.150	1.665	0.236	0.276	0.701	1.305	1.502	63,766	10,591	6.196
40B	2.500	1.500	1.550	2.085	0.315	0.323	0.901	1.626	2.028	93,773	15,224	10.953
48B	3.000	1.800	1.900	2.515	0.374	0.472	1.151	1.951	2.364	141,211	23,167	16.799
56B	3.500	2.100	2.125	3.063	0.472	0.531	1.351	2.256	2.587	211,321	17,064	23.875
64B	4.000	2.400	2.500	3.530	0.512	0.591	1.551	2.565	2.947	278,764	22,527	30.756
72B	4.500	2.700	2.850	4.079	0.591	0.669	1.751	2.894	3.248	348,456	28,193	40.654

*Straight Side Bar

ISO BRITISH METRIC STANDARD ROLLER CHAIN DOUBLE STRAND



1. Our PEER Chain precision roller chains are manufactured to **exceed ISO606** requirements.
2. All chain components are **heat-treated** to achieve maximum strength and greater wear resistance.
3. All PEER roller chain is **pre-loaded** during the manufacturing process to minimize initial elongation.
4. **Hot-dipped lubrication** ensures 100% lubrication of all chain components to extend wear life and reduce maintenance costs.

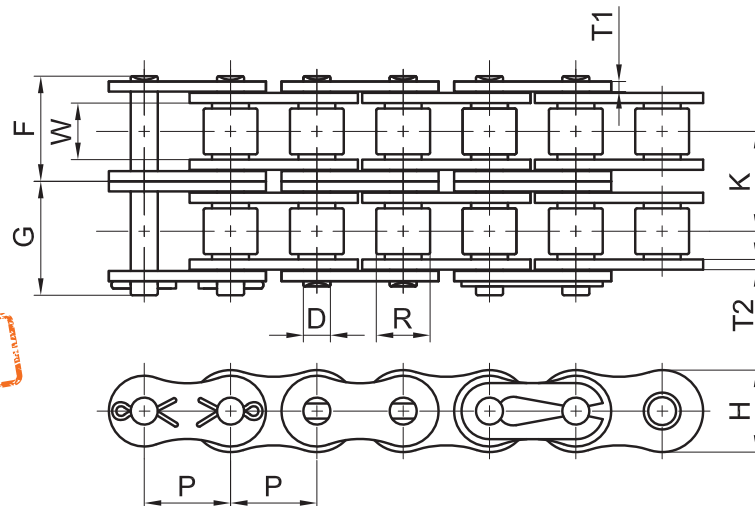

Dimensions: inch

Chain No.	Pitch P	Roller		Plate			Pin Dia. D	Overall Width		Transverse Pitch K	Avg. Ult. Tensile Strength (Lbs.)	Max. Working Load (Lbs.)	Avg. Weight Per Foot (Lbs.)
		Width W	Dia. R	Height H	Thickness T1 T2	F		G					
06B-2*	0.375	0.225	0.250	0.325	0.039	0.050	0.129	0.444	0.521	0.403	4,277	661	0.497
08B-2	0.500	0.305	0.335	0.465	0.059	0.062	0.175	0.609	0.672	0.548	7,937	1,433	0.874
10B-2	0.625	0.380	0.400	0.580	0.067	0.067	0.200	0.710	1.138	0.653	11,993	1,874	1.216
12B-2	0.750	0.460	0.475	0.635	0.073	0.073	0.225	0.836	0.946	0.766	14,462	2,646	1.613
16B-2	1.000	0.670	0.625	0.830	0.125	0.157	0.326	1.343	1.410	1.255	34,216	5,952	3.541
20B-2	1.250	0.770	0.750	1.040	0.125	0.176	0.401	1.512	1.661	1.435	46,297	7,165	4.811
24B-2	1.500	1.000	1.000	1.315	0.189	0.236	0.576	2.003	2.235	1.904	79,366	12,015	9.408
28B-2	1.750	1.220	1.100	1.460	0.236	0.287	0.626	2.469	2.658	2.345	114,640	16,865	12.741
32B-2	2.000	1.220	1.150	1.665	0.236	0.276	0.701	2.457	2.656	2.305	127,427	17,968	13.231
40B-2	2.500	1.500	1.550	2.085	0.315	0.323	0.901	3.049	3.451	2.846	187,393	25,794	21.503
48B-2	3.000	1.800	1.900	2.515	0.374	0.472	1.151	3.748	4.161	3.591	282,191	39,352	33.598
56B-2	3.500	2.100	2.125	3.063	0.472	0.531	1.351	4.354	4.685	4.197	395,663	47,480	47.273
64B-2	4.000	2.400	2.500	3.530	0.512	0.591	1.551	4.925	5.311	4.720	494,577	59,350	61.149
72B-2	4.500	2.700	2.850	4.079	0.591	0.669	1.751	5.571	5.925	5.365	618,225	74,180	80.636

*Straight Side Bar 

ISO BRITISH METRIC STANDARD ROLLER CHAIN TRIPLE STRAND



1. Our PEER Chain precision roller chains are manufactured to **exceed ISO606** requirements.
2. All chain components are **heat-treated** to achieve maximum strength and greater wear resistance.
3. All PEER roller chain is **pre-loaded** during the manufacturing process to minimize initial elongation.
4. **Hot-dipped lubrication** ensures 100% lubrication of all chain components to extend wear life and reduce maintenance costs.

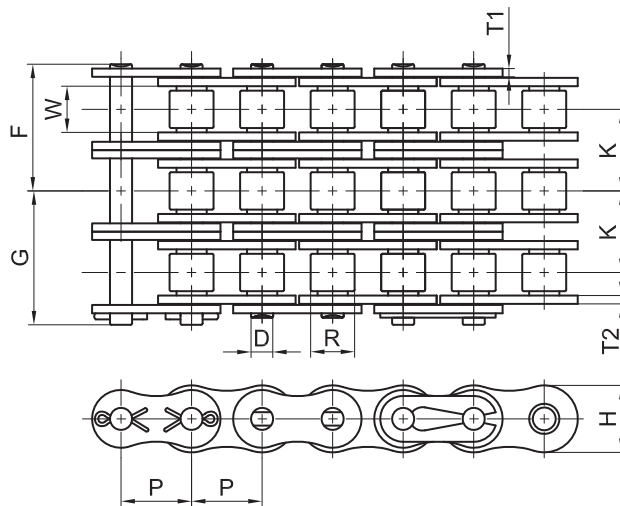

Dimensions: inch

Chain No.	Pitch P	Roller		Plate			Pin Dia. D	Overall Width		Transverse Pitch K	Avg. Ult. Tensile Strength (Lbs.)	Max. Working Load (Lbs.)	Avg. Weight Per Foot (Lbs.)
		Width W	Dia. R	Height H	Thickness T1	T2		F	G				
06B-3*	0.375	0.225	0.250	0.325	0.039	0.050	0.129	0.647	0.696	0.403	6,283	992	0.739
08B-3	0.500	0.305	0.335	0.465	0.059	0.062	0.175	0.890	0.949	0.548	11,244	2,205	1.310
10B-3	0.625	0.380	0.400	0.580	0.067	0.067	0.200	1.046	1.106	0.653	17,990	2,756	1.814
12B-3	0.750	0.460	0.475	0.635	0.073	0.073	0.225	1.220	1.288	0.766	21,693	3,858	2.412
16B-3	1.000	0.670	0.625	0.830	0.125	0.157	0.326	1.971	2.054	1.255	51,324	8,818	5.295
20B-3	1.250	0.770	0.750	1.040	0.125	0.176	0.401	2.228	2.409	1.435	69,446	10,472	7.224
24B-3	1.500	1.000	1.000	1.315	0.189	0.236	0.576	2.967	3.176	1.904	119,049	17,637	13.937
28B-3	1.750	1.220	1.100	1.460	0.236	0.287	0.626	3.831	3.642	2.345	171,600	24,750	20.24
32B-3	2.000	1.220	1.150	1.665	0.236	0.276	0.701	3.807	3.610	2.305	190,740	26,400	19.74
40B-3	2.500	1.500	1.550	2.085	0.315	0.323	0.901	4.874	4.472	2.846	280,500	37,950	33.93
48B-3	3.000	1.800	1.900	2.515	0.374	0.472	1.151	5.957	5.543	3.591	422,400	52,800	53.57
56B-3	3.500	2.100	2.125	3.063	0.472	0.531	1.351	6.453	6.791	4.197	503,574	55,393	75.71
64B-3	4.000	2.400	2.500	3.530	0.512	0.591	1.551	7.285	7.675	4.720	741,873	81,606	97.14
72B-3	4.500	2.700	2.850	4.079	0.591	0.669	1.751	8.268	8.622	5.365	927,341	102,008	128.43

*Straight Side Bar

ISO BRITISH METRIC STANDARD ROLLER CHAIN C TYPE



1. Constructed with **straight side plates** rather than peanut-shaped for slightly increased fatigue strength.
2. All chain components are **heat-treated** to achieve maximum strength and greater wear resistance.
3. All PEER roller chain is **pre-loaded** during the manufacturing process to minimize initial elongation.
4. **Hot-dipped lubrication** ensures 100% lubrication of all chain components to extend wear life and reduce maintenance costs.

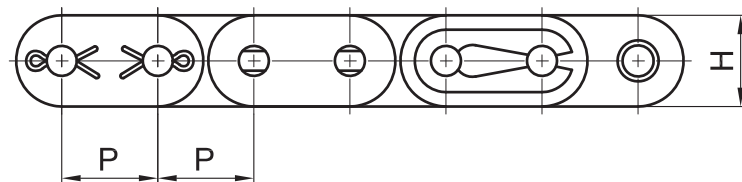
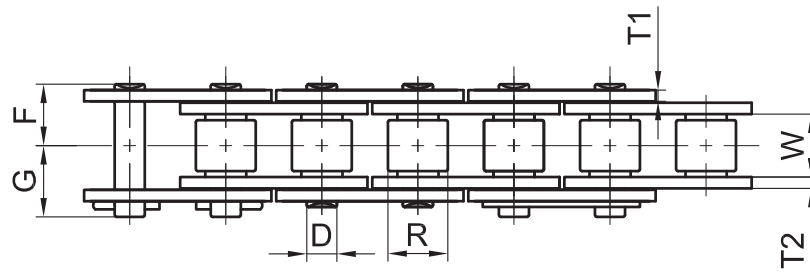

Dimensions: inch

Chain No.	Pitch P	Roller		Plate			Pin Dia. D	Overall Width		Avg. Ult. Tensile Strength (Lbs.)	Max. Working Load (Lbs.)	Avg. Weight Per Foot (Lbs.)
		Width W	Dia. R	Height H	Thickness T1 T2			F	G			
C06B*	0.375	0.225	0.250	0.325	0.039	0.050	0.129	0.241	0.279	2,381	357	0.28
C08B	0.500	0.305	0.335	0.463	0.059	0.062	0.175	0.324	0.407	4,233	635	0.50
C10B	0.625	0.380	0.400	0.580	0.067	0.067	0.200	0.388	0.482	5,997	899	0.66
C12B	0.750	0.460	0.475	0.635	0.073	0.073	0.225	0.444	0.574	7,231	1,085	0.86
C16B	1.000	0.670	0.625	0.830	0.125	0.157	0.326	0.713	0.831	17,108	2,566	1.94
C20B	1.250	0.770	0.750	1.024	0.125	0.176	0.401	0.791	0.961	23,149	3,472	2.59
C24B	1.500	1.000	1.000	1.283	0.189	0.236	0.576	1.066	1.267	39,683	5,952	4.93
C28B	1.750	1.220	1.100	1.460	0.236	0.287	0.626	1.297	1.474	57,320	8,598	6.59
C32B	2.000	1.220	1.150	1.665	0.236	0.276	0.701	1.305	1.502	63,714	9,557	6.83

*Straight Side Bar 

ISO BRITISH METRIC STANDARD ROLLER CHAIN HEAVY H SERIES



1. Heavy Series chain incorporates **thicker** plates for greater **strength** and **durability**.
2. All chain components are **heat-treated** to achieve maximum strength and greater wear resistance.
3. All PEER roller chain is **pre-loaded** during the manufacturing process to minimize initial elongation.
4. **Hot-dipped lubrication** ensures 100% lubrication of all chain components to extend wear life and reduce maintenance costs.

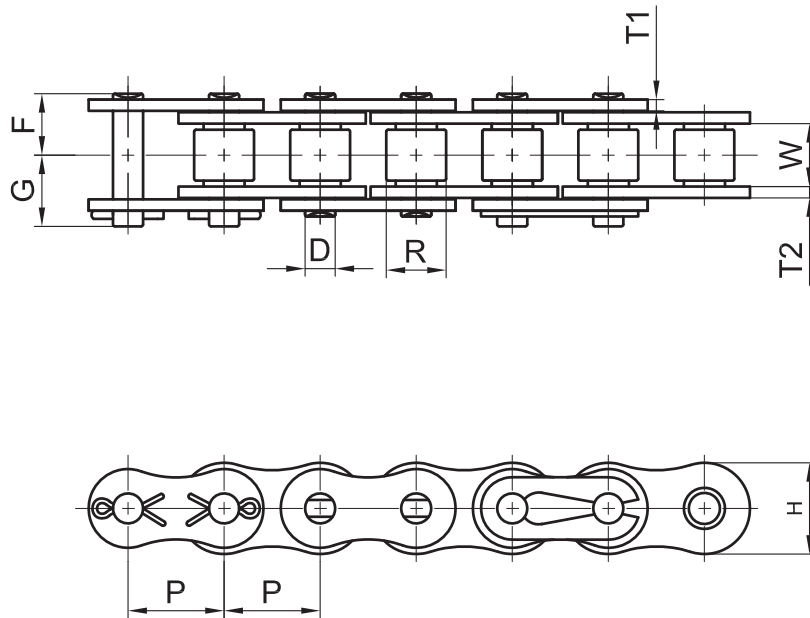

Dimensions: inch

Chain No.	Pitch P	Roller		Plate		Pin Dia. D	Overall Width		Transverse Pitch K	Avg. Ult. Tensile Strength (Lbs.)	Max. Working Load (Lbs.)	Avg. Weight Per Foot (Lbs.)
		Width W	Dia. R	Height H	Thickness T		F	G				
04BH	0.236	0.110	0.157	0.197	0.035	0.073	0.165	0.205	0	1,124	169	0.101
06BH*	0.375	0.225	0.250	0.325	0.063	0.129	0.283	0.323	0	2,529	379	0.343
08BH	0.500	0.305	0.335	0.465	0.080	0.175	0.366	0.421	0	4,631	695	0.531
10BH	0.625	0.380	0.400	0.580	0.080	0.200	0.406	0.469	0	5,036	755	0.732
10BH-2	0.625	0.380	0.400	0.580	0.080	0.200	0.768	0.819	0.705	10,004	1,501	1.445
12BH	0.750	0.460	0.475	0.635	0.095	0.225	0.484	0.543	0	6,519	978	0.981
12BH-2	0.750	0.460	0.475	0.635	0.095	0.225	0.972	0.916	0.856	12,994	1,949	1.949
16BH	1.000	0.670	0.625	0.830	0.161	0.326	0.740	0.858	0	13,489	2,023	2.063
16BH-2	1.000	0.670	0.625	0.830	0.161	0.326	1.409	1.524	1.335	23,830	3,574	4.079

*Straight Side Bar



CORROSION RESISTANT

At PEER Chain, we offer chain that provides high resistance to corrosion using coatings or stainless alloys that are intended for use in corrosive working environments. Corrosion-resistant chain is often used in applications with high humidity, outdoor, and saltwater environments. PEER Chain provides several options for corrosion resistance, which include ProCoat™, nickel-plated, zinc-plated, and stainless (304, 600, 316).



CORROSION

Chain Material	Temperature Range
Nickel-Plated	10°F - 150°F
Zinc-Coated	10°F - 150°F
ProCoat	10°F - 350°F
304 SS	-40°F - 750°F
316 MSS	-40°F - 750°F
600 PHSS	-20°F - 500°F

PEER Chain Nickel-Plated chains deliver performance when your operations include mildly corrosive environments.

PEER Chain Zinc-Plated™.

PEER Zinc-Plated Roller chain provides corrosion resistance for applications with high humidity and salt-water exposures or wash-downs. Zinc coating is evenly applied to carbon steel pins, bushings, rollers, and plates prior to chain assembly. Utilizing a carbon steel substrate allows the chain to maintain a cost effective, corrosion-resistant solution while maintaining strength and wear life.

PEER ProCoat™ corrosion-resistant roller chain fights corrosion when exposed to some of the harshest outdoor environments, even seawater. With ProCoat™, you get the durability and load-bearing features of carbon steel, but with corrosion protection that is superior to other moisture-proof chains, including nickel-plated chain.

PEER Stainless Steel Chain incorporates Quest™ Solid Bushing Technology, which provides a smoother, more cylindrical inside bushing wall. Contact between the pin and bushing is maintained along the entire inside length of the bushing, improving wear life. Quest™ Solid Bushings and Solid Rollers are standard on our 304 SS Series Roller Chain, and are available on our 316 MSS Series and 600 PHSS Series Roller Chain.

RESISTANT

304 SS Series | 304 Stainless Steel Roller Chain

- Provides excellent corrosion resistance for chemical and acidic environments
- Provides exceptional corrosion resistance for food contact or low magnetic permeable applications
- Constructed with all 304 series austenitic stainless steel pins, bushing, rollers and plates
- Effectively performs in harsh temperature environments ranging from -40°F to 750°F
- Non-sparking

316 MSS Series | 316 Stainless Steel Roller Chain

- Provides remarkable corrosion resistance for chemical and acidic environments, especially where chlorine and sulfur are present
- Provides corrosion resistance for food contact or low magnetic permeable applications
- Constructed with all 316 series austenitic stainless steel pins, bushing, rollers and plates
- Effectively performs in harsh temperature environments ranging from -40°F to 750°F
- Considered as non-magnetic
- Non-sparking

600 PHSS Series | 600 Stainless Steel Roller Chain

- Provides corrosion resistance for applications requiring higher working load
- Constructed with 304 series plates and 600 series hardened stainless steel pins, bushings, and rollers for greater strength and wear performance than 304 and 316 series
- Effectively performs in harsh temperature environments ranging from -20°F to 500°F
- Working load of 600 series is higher than 304 and 316 series
- 600 series provides better wear-life than all 304 and 316 series

Word Search

D P S J D L B K P A P S Y N L B E
O N T S H T O B E C Y R E O S U U
U I A P I C B K E A L S O W L K V
B C I R Z M E T R I C Q R C M P E
L K N O Z D X A C N O M Y P O R Q
E E L C U D B R H E A W Z D B A L
P L E K X S V Q A Y B A I S P E T
I R S E B F H U I W B Z N X C V B
T N S T M N Y A N S I W C E R T Y
C P R S D F G H U R G N W Y N E X
H T D P L H E A V Y R V T B Y J F

ANSI
DOUBLEPITCH
HEAVY
METRIC
NICKEL
PEERCHAIN
PROCOAT
SPROCKET
STAINLESS
ZINC

**At the beginning of each Escape Room, you will find a puzzle. Solve each puzzle to find the cryptic message in each Escape Room. Once you have completed the puzzles, visit our website (peerchain.com) and search for the discrete door and enter! Once you complete the form, what follows is all about our relationship with you!*

ANSI/ASME STANDARD



1. Provides **excellent corrosion resistance** and commonly used in applications with high humidity, outdoor environments, and saltwater applications.
2. **Stronger**, more impact-resistant than Stainless Steel.
3. ProCoat™ offers the **durability** and load-bearing features of Carbon Steel.
4. All PEER roller chain is **pre-loaded** during the manufacturing process to minimize initial elongation.

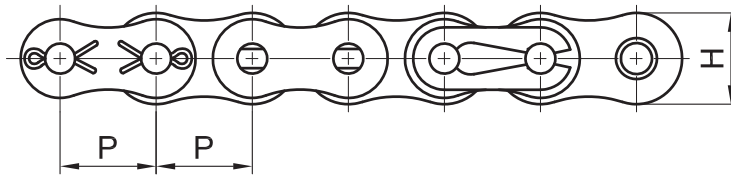
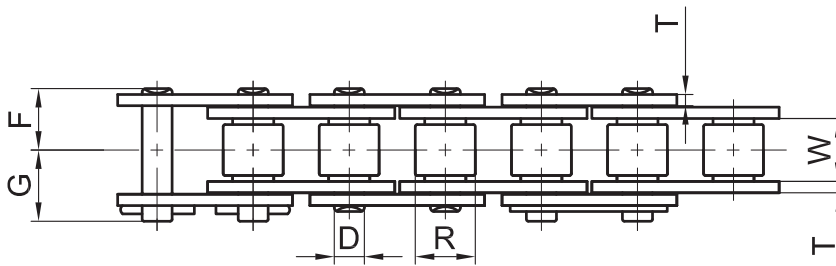

Dimensions: inch

Chain No.	Pitch P	Roller		Plate		Pin Dia. D	Overall Width		Avg. Ult. Tensile Strength (Lbs.)	Max. Working Load (Lbs.)	Avg. Weight Per Foot (Lbs.)
		Width W	Dia. R	Height H	Thickness T		F	G			
25PRO	0.250	0.125	0.130	0.228	0.030	0.091	0.154	0.185	1,036	165	0.087
35PRO	0.375	0.188	0.200	0.356	0.050	0.142	0.232	0.303	2,469	485	0.215
41PRO	0.500	0.250	0.306	0.390	0.050	0.142	0.263	0.334	2,866	529	0.276
40PRO	0.500	0.312	0.312	0.475	0.060	0.157	0.324	0.406	4,188	816	0.417
50PRO	0.625	0.375	0.400	0.594	0.080	0.200	0.400	0.488	6,834	1,400	0.679
60PRO	0.750	0.500	0.469	0.712	0.094	0.235	0.501	0.601	9,259	2,094	0.974
80PRO	1.000	0.625	0.625	0.950	0.125	0.313	0.650	0.803	17,636	3,307	1.714
100PRO	1.250	0.750	0.750	1.187	0.156	0.376	0.781	0.950	25,353	5,071	2.654
120PRO	1.500	1.000	0.875	1.425	0.187	0.437	1.005	1.174	34,392	6,834	3.790
140PRO	1.750	1.000	1.000	1.662	0.219	0.500	1.074	1.267	46,297	9,039	4.959
160PRO	2.000	1.250	1.125	1.900	0.250	0.563	1.290	1.459	57,761	11,905	6.317
180PRO	2.250	1.406	1.406	2.137	0.281	0.687	1.443	1.659	84,216	13,669	8.514
200PRO	2.500	1.500	1.562	2.375	0.312	0.781	1.589	1.825	109,128	16,094	10.684
240PRO	3.000	1.875	1.875	2.850	0.375	0.937	1.943	2.179	154,323	29,762	16.396

PROCOAT™

ANSI/ASME STANDARD HEAVY H SERIES



1. ProCoat™ Heavy Series chain incorporates **thicker** plates for greater **strength** and **durability**.
2. Provides **excellent corrosion resistance** and commonly used in applications with high humidity, outdoor environments, and saltwater applications.
3. ProCoat™ Heavy Series offers the **durability** and load-bearing features of Carbon Steel.
4. All PEER roller chain is **pre-loaded** during the manufacturing process to minimize initial elongation.

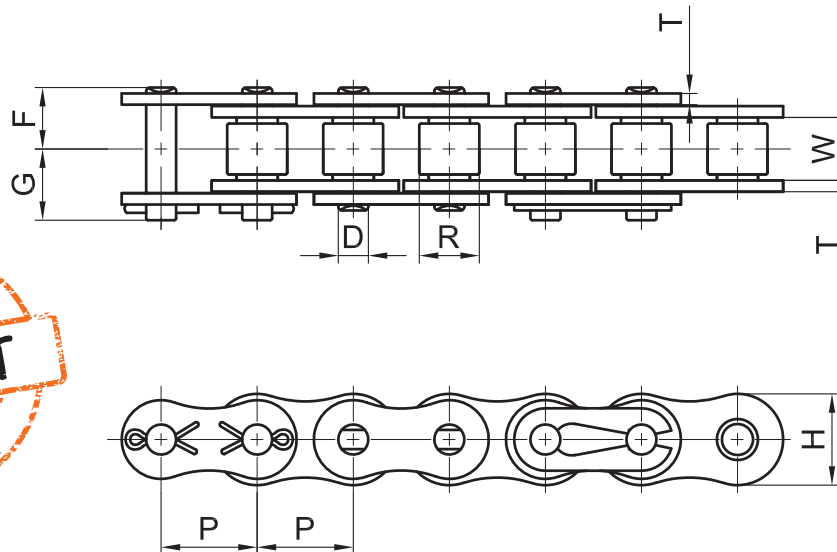

Dimensions: inch

Chain No.	Pitch P	Roller		Plate		Pin Dia. D	Overall Width		Avg. Ult. Tensile Strength (Lbs.)	Max. Working Load (Lbs.)	Avg. Weight Per Foot (Lbs.)
		Width	Dia.	Height	Thickness		F	G			
		W	R	H	T						
50HPRO	0.625	0.375	0.400	0.573	0.094	0.200	0.435	0.526	8,157	1,224	0.766
60HPRO	0.750	0.500	0.469	0.765	0.125	0.235	0.567	0.665	11,905	2,157	1.162
80HPRO	1.000	0.625	0.625	0.956	0.156	0.313	0.715	0.888	21,494	3,564	1.995
100HPRO	1.250	0.750	0.750	1.146	0.187	0.376	0.860	0.998	30,424	5,544	3.017
120HPRO	1.500	1.000	0.875	1.464	0.219	0.437	1.072	1.265	41,447	6,897	4.206
140HPRO	1.750	1.000	1.000	1.530	0.250	0.500	1.144	1.345	54,895	9,500	5.476
160HPRO	2.000	1.250	1.125	1.846	0.281	0.563	1.339	1.546	68,784	11,020	7.109
180HPRO	2.250	1.406	1.406	2.067	0.312	0.687	1.521	1.738	97,444	15,099	9.206
200HPRO	2.500	1.500	1.562	2.295	0.375	0.781	1.715	1.934	113,758	17,558	12.834
240HPRO	3.000	1.875	1.875	2.935	0.375	0.937	2.533	2.533	210,541	25,211	19.856

**ANSI/ASME STANDARD
 DOUBLE PITCH
 A TYPE**



1. Designed for **low speed** and long distance **conveyor applications**.
2. Provides **excellent corrosion resistance** and commonly used in applications with high humidity, outdoor environments, and saltwater applications.
3. ProCoat™ offers the **durability** and load-bearing features of Carbon Steel.
4. All PEER roller chain is **pre-loaded** during the manufacturing process to minimize initial elongation.

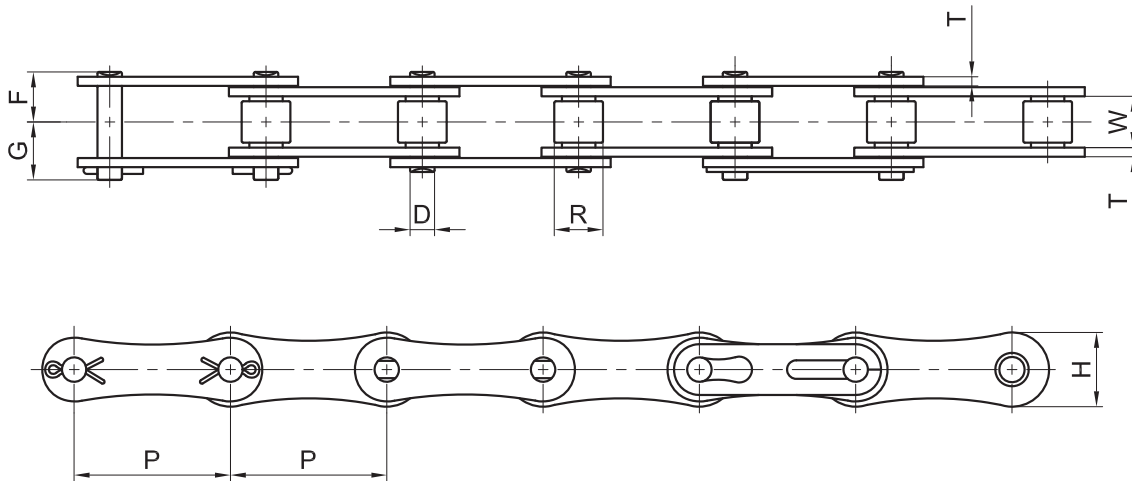

Dimensions: inch

Chain No.	Pitch	Roller		Plate		Pin Dia.	Overall Width		Avg. Ult. Tensile Strength (Lbs.)	Max. Working Load (Lbs.)	Avg. Weight Per Foot (Lbs.)
		Width	Dia.	Height	Thickness		F	G			
	P	W	R	H	T	D	F	G			
A2040PRO	1.000	0.312	0.312	0.475	0.060	0.157	0.324	0.406	4,189	661	0.276
A2042PRO	1.000	0.312	0.625	0.475	0.060	0.157	0.324	0.406	4,189	661	0.276
A2050PRO	1.250	0.375	0.400	0.594	0.080	0.200	0.400	0.488	6,834	990	0.457
A2052PRO	1.250	0.375	0.750	0.594	0.080	0.200	0.400	0.488	6,834	990	0.457
A2060PRO	1.500	0.500	0.469	0.712	0.094	0.235	0.501	0.601	9,259	1,430	0.638
A2062PRO	1.500	0.500	0.875	0.712	0.094	0.235	0.501	0.601	9,259	1,430	0.638
A2080PRO	2.000	0.625	0.625	0.950	0.125	0.313	0.650	0.803	17,637	2,420	1.176
A2082PRO	2.000	0.625	1.125	0.950	0.125	0.313	0.650	0.803	17,637	2,420	1.176

PROCOAT™

ANSI/ASME STANDARD DOUBLE PITCH C TYPE



1. Designed for **low speed** and long distance **conveyor applications**.
2. Provides **excellent corrosion resistance** and commonly used in applications with high humidity, outdoor environments, and saltwater applications.
3. ProCoat™ offers the **durability** and load-bearing features of Carbon Steel.
4. All PEER roller chain is **pre-loaded** during the manufacturing process to minimize initial elongation.

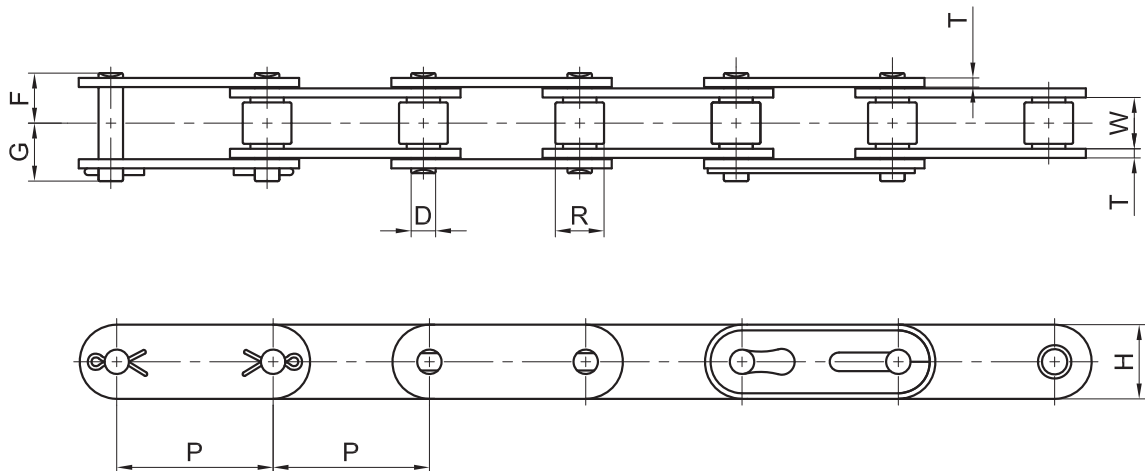

Dimensions: inch

Chain No.	Pitch P	Roller		Plate		Pin Dia. D	Overall Width		Avg. Ult. Tensile Strength (Lbs.)	Max. Working Load (Lbs.)	Avg. Weight Per Foot (Lbs.)
		Width W	Dia. R	Height H	Thickness T		F	G			
C2040PRO	1.000	0.312	0.312	0.475	0.060	0.157	0.324	0.406	4,189	661	0.316
C2042PRO	1.000	0.312	0.625	0.475	0.060	0.157	0.324	0.406	4,189	661	0.558
C2050PRO	1.250	0.375	0.400	0.594	0.080	0.200	0.400	0.488	6,834	992	0.538
C2052PRO	1.250	0.375	0.750	0.594	0.080	0.200	0.400	0.488	6,834	992	0.853
C2060PRO	1.500	0.500	0.469	0.712	0.094	0.235	0.501	0.601	9,259	1,433	0.759
C2060HPRO	1.500	0.500	0.469	0.712	0.125	0.235	0.567	0.606	12,125	1,543	0.947
C2062HPRO	1.500	0.500	0.875	0.712	0.125	0.235	0.567	0.606	12,125	1,543	1.431
C2080HPRO	2.000	0.625	0.625	0.950	0.156	0.313	0.715	0.888	20,503	2,646	1.599
C2082HPRO	2.000	0.625	1.125	0.950	0.156	0.313	0.715	0.888	20,503	2,646	2.318
C2100HPRO	2.500	0.750	0.750	1.187	0.187	0.376	0.860	0.998	30,865	4,079	2.459
C2102HPRO	2.500	0.750	1.562	1.187	0.187	0.376	0.860	0.998	30,865	4,079	3.944
C2120HPRO	3.000	1.000	0.875	1.369	0.219	0.437	1.072	1.265	40,345	5,512	3.481
C2122HPRO	3.000	1.000	1.750	1.369	0.219	0.437	1.072	1.265	40,345	5,512	5.436
C2160HPRO	4.000	1.250	1.125	1.900	0.281	0.562	1.339	1.546	69,446	9,259	5.745
C2162HPRO	4.000	1.250	2.250	1.900	0.281	0.562	1.339	1.546	69,446	9,259	8.729



PROCOAT™

ISO BRITISH METRIC STANDARD

1. Provides **excellent corrosion resistance** and commonly used in applications with high humidity, outdoor environments, and saltwater applications.
2. **Stronger**, more impact-resistant than Stainless Steel.
3. ProCoat offers the **durability** and load-bearing features of Carbon Steel.
4. All PEER roller chain is **pre-loaded** during the manufacturing process to minimize initial elongation.

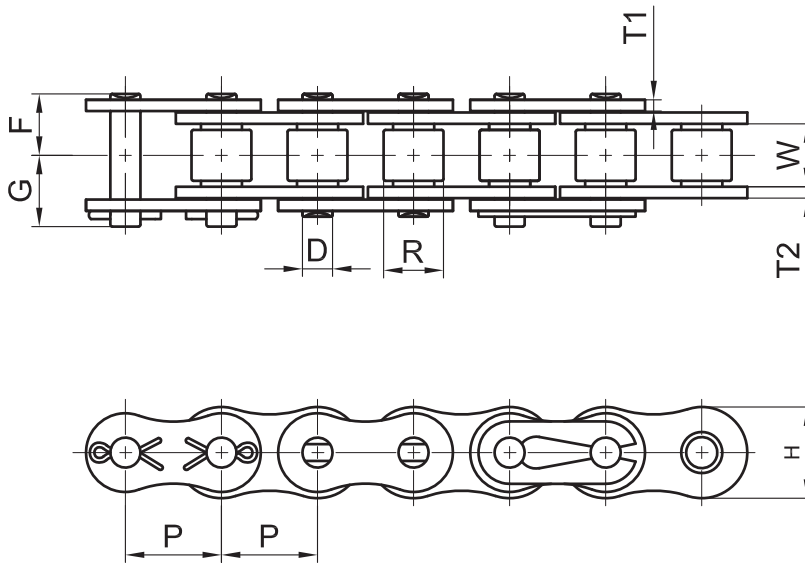

Dimensions: inch

Chain No.	Pitch P	Roller		Plate		Pin Dia. D	Overall Width		Avg. Ult. Tensile Strength (Lbs.)	Max. Working Load (Lbs.)	Avg. Weight Per Foot (Lbs.)	
		Width W	Dia. R	Height H	Thickness T1 T2		F	G				
04BPRO	0.236	0.110	0.157	0.197	0.024	0.024	0.073	0.132	0.175	728	132	0.087
05BPRO	0.315	0.118	0.197	0.280	0.031	0.031	0.091	0.154	0.185	1,279	243	0.108
06BPRO	0.375	0.225	0.250	0.325	0.039	0.050	0.129	0.241	0.279	2,381	397	0.276
08BPRO	0.500	0.305	0.335	0.430	0.059	0.062	0.175	0.324	0.368	4,233	882	0.443
083PRO	0.500	0.192	0.305	0.406	0.050	0.050	0.161	0.254	0.274	3,307	551	0.282
10BPRO	0.625	0.380	0.400	0.540	0.067	0.067	0.200	0.388	0.455	5,997	1,102	0.618
12BPRO	0.750	0.460	0.475	0.635	0.073	0.073	0.225	0.444	0.526	7,231	1,543	0.813
16BPRO	1.000	0.670	0.625	0.830	0.125	0.157	0.326	0.713	0.776	17,108	3,527	1.787
20BPRO	1.250	0.770	0.750	1.040	0.125	0.176	0.401	0.791	0.961	23,149	4,189	2.433
24BPRO	1.500	1.000	1.000	1.315	0.189	0.236	0.576	1.066	1.267	39,683	7,055	4.737
28BPRO	1.750	1.220	1.100	1.460	0.236	0.287	0.626	1.474	1.297	57,200	9,900	6.84
32BPRO	2.000	1.220	1.150	1.665	0.236	0.276	0.701	1.502	1.305	63,580	10,560	6.59

NICKEL-PLATED ANSI/ASME STANDARD



1. Nickel-Plated Roller chain provides **corrosion resistance** for applications with high humidity and water exposures or wash-downs.
2. All chain components are **heat-treated** to achieve maximum strength and greater wear resistance.
3. All PEER roller chain is **pre-loaded** during the manufacturing process to minimize initial elongation.
4. **Hot-dipped lubrication** ensures 100% lubrication of all chain components to extend wear life and reduce maintenance costs.

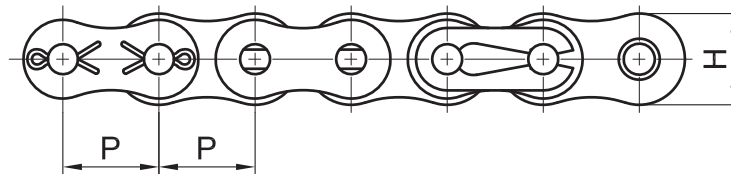
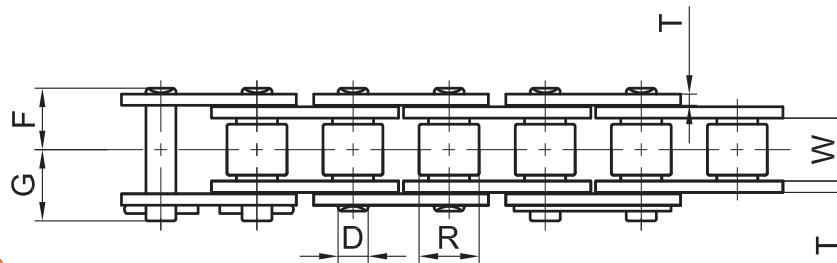

Dimensions: inch

Chain No.	Pitch P	Roller		Plate		Pin Dia. D	Overall Width		Avg. Ult. Tensile Strength (Lbs.)	Max. Working Load (Lbs.)	Avg. Weight Per Foot (Lbs.)
		Width W	Dia. R	Height H	Thickness T		F	G			
25NP	0.250	0.125	0.130	0.228	0.030	0.091	0.154	0.185	1036	110	0.087
35NP	0.375	0.188	0.200	0.356	0.050	0.142	0.232	0.277	2469	390	0.215
41NP	0.500	0.250	0.306	0.390	0.050	0.142	0.263	0.334	2866	368	0.276
40NP	0.500	0.312	0.312	0.475	0.060	0.157	0.324	0.406	4188	650	0.417
50NP	0.625	0.375	0.400	0.594	0.080	0.200	0.400	0.488	6834	1120	0.679
60NP	0.750	0.500	0.469	0.673	0.094	0.234	0.500	0.549	9259	1675	0.974
80NP	1.000	0.625	0.625	0.950	0.125	0.313	0.650	0.803	17636	2650	1.714
100NP	1.250	0.750	0.750	1.187	0.156	0.376	0.781	0.950	25353	4050	2.654
120NP	1.500	1.000	0.875	1.425	0.187	0.437	1.005	1.174	34392	5470	3.79
140NP	1.750	1.000	1.000	1.662	0.219	0.500	1.074	1.267	46297	7240	4.959
160NP	2.000	1.250	1.125	1.900	0.250	0.563	1.290	1.459	57761	9525	6.317

NICKEL-PLATED ANSI/ASME STANDARD DOUBLE PITCH A TYPE



1. Designed for **low speed** and long distance **drive applications**.
2. Nickel-plated roller chain provides a **quality corrosion resistance** for applications with high humidity and water exposures or wash-downs.
3. All PEER roller chain is **pre-loaded** during the manufacturing process to minimize initial elongation.
4. **Hot-dipped lubrication** ensures 100% lubrication of all chain components to extend wear life and reduce maintenance costs.

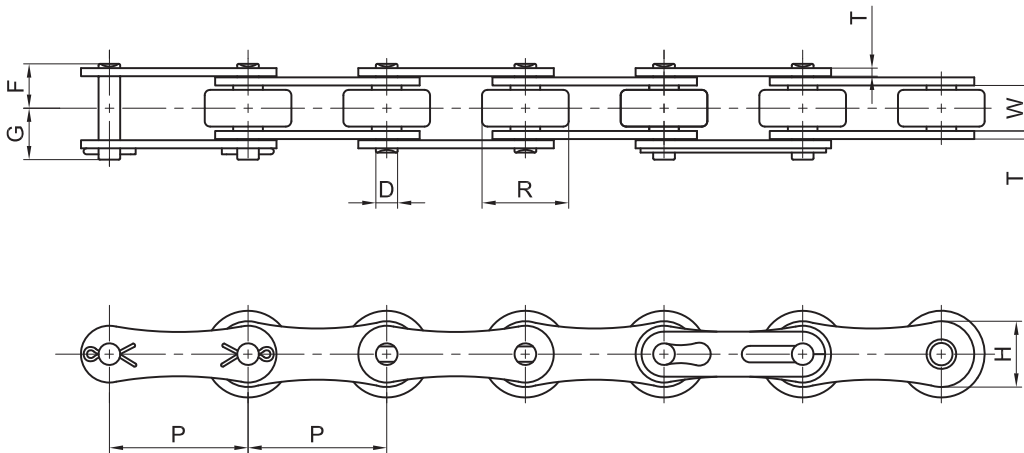

Dimensions: inch

Chain No.	Pitch	Roller		Plate		Pin Dia.	Overall Width		Avg. Ult. Tensile Strength (Lbs.)	Max. Working Load (Lbs.)	Avg. Weight Per Foot (Lbs.)
		Width	Dia.	Height	Thickness		F	G			
	P	W	R	H	T	D	F	G			
A2040NP	1.000	0.312	0.312	0.475	0.060	0.157	0.324	0.406	4,189	661	0.276
A2042NP	1.000	0.312	0.625	0.475	0.060	0.157	0.324	0.406	4,189	661	0.276
A2050NP	1.250	0.375	0.400	0.594	0.080	0.200	0.400	0.488	6,834	990	0.457
A2052NP	1.250	0.375	0.750	0.594	0.080	0.200	0.400	0.488	6,834	990	0.457
A2060NP	1.500	0.500	0.469	0.712	0.094	0.235	0.501	0.601	9,259	1,430	0.638
A2062NP	1.500	0.500	0.875	0.712	0.094	0.235	0.501	0.601	9,259	1,430	0.638
A2080NP	2.000	0.625	0.625	0.950	0.125	0.313	0.650	0.803	17,637	2,420	1.176
A2082NP	2.000	0.625	1.125	0.950	0.125	0.313	0.650	0.803	17,637	2,420	1.176

NICKEL-PLATED ANSI/ASME STANDARD DOUBLE PITCH C TYPE



1. Designed for **low speed** and long distance **conveyor applications**.
2. Nickel-plated roller chain provides a **quality corrosion resistance** for applications with high humidity and water exposures or wash-downs.
3. All PEER roller chain is **pre-loaded** during the manufacturing process to minimize initial elongation.
4. **Hot-dipped lubrication** ensures 100% lubrication of all chain components to extend wear life and reduce maintenance costs.

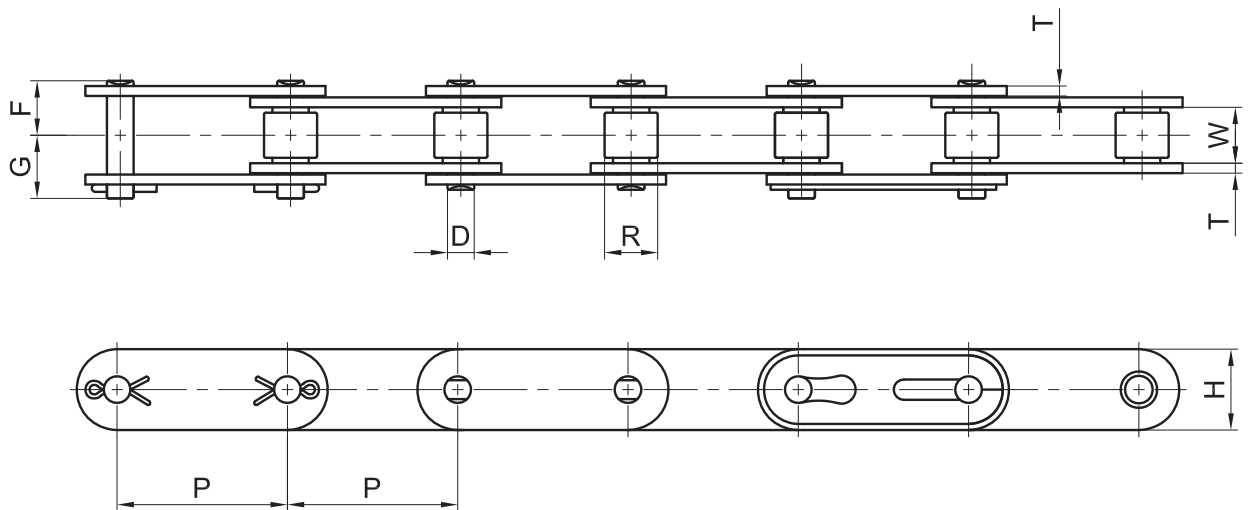

Dimensions: inch

Chain No.	Pitch P	Roller		Plate		Pin Dia. D	Overall Width		Avg. Ult. Tensile Strength (Lbs.)	Max. Working Load (Lbs.)	Avg. Weight Per Foot (Lbs.)
		Width W	Dia. R	Height H	Thickness T		F	G			
C2040NP	1.000	0.312	0.312	0.475	0.060	0.157	0.324	0.406	4,189	661	0.316
C2042NP	1.000	0.312	0.625	0.475	0.060	0.157	0.324	0.406	4,189	661	0.558
C2050NP	1.250	0.375	0.400	0.594	0.080	0.200	0.400	0.488	6,834	990	0.538
C2052NP	1.250	0.375	0.750	0.594	0.080	0.200	0.400	0.488	6,834	990	0.853
C2060NP	1.500	0.500	0.469	0.712	0.094	0.235	0.501	0.601	9,259	1,433	0.759
C2060HNP	1.500	0.500	0.469	0.712	0.125	0.235	0.567	0.606	12,125	1,543	0.947
C2062HNP	1.500	0.500	0.875	0.712	0.125	0.235	0.567	0.606	12,125	1,543	1.431
C2080HNP	2.000	0.625	0.625	0.950	0.156	0.313	0.715	0.888	20,503	2,646	1.599
C2082HNP	2.000	0.625	1.125	0.950	0.156	0.313	0.715	0.888	20,503	2,646	2.318
C2100HNP	2.500	0.750	0.750	1.187	0.187	0.376	0.860	0.998	30,865	4,079	2.459
C2102HNP	2.500	0.750	1.562	1.187	0.187	0.376	0.860	0.998	30,865	4,079	3.944
C2120HNP	3.000	1.000	0.875	1.369	0.219	0.437	1.072	1.265	40,345	5,512	3.481
C2122HNP	3.000	1.000	1.750	1.369	0.219	0.437	1.072	1.265	40,345	5,512	5.436
C2160HNP	4.000	1.250	1.125	1.900	0.281	0.562	1.339	1.546	69,446	9,259	5.745
C2162HNP	4.000	1.250	2.250	1.900	0.281	0.562	1.339	1.546	69,446	9,259	8.729

NICKEL-PLATED ISO BRITISH METRIC STANDARD



1. Nickel-plated roller chain provides **corrosion resistance** for applications with high humidity and water exposures or wash-downs.
2. All chain components are **heat-treated** to achieve maximum strength and greater wear resistance.
3. All PEER roller chain is **pre-loaded** during the manufacturing process to minimize initial elongation.
4. **Hot-dipped lubrication** ensures 100% lubrication of all chain components to extend wear life and reduce maintenance costs.

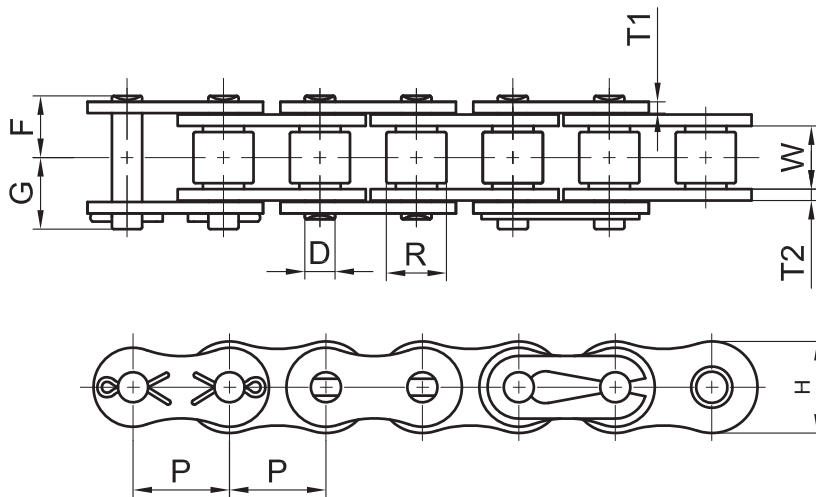

Dimensions: inch

Chain No.	Pitch P	Roller		Plate		Pin Dia. D	Overall Width		Avg. Ult. Tensile Strength (Lbs.)	Max. Working Load (Lbs.)	Avg. Weight Per Foot (Lbs.)	
		Width W	Dia. R	Height H	Thickness T1 T2		F	G				
04BNP	0.236	0.110	0.157	0.197	0.024	0.024	0.073	0.132	0.175	728	110	0.087
05BNP	0.315	0.118	0.197	0.280	0.031	0.031	0.091	0.154	0.185	1,279	200	0.108
06BNP	0.375	0.225	0.250	0.325	0.039	0.050	0.129	0.241	0.279	2,381	315	0.276
08BNP	0.500	0.305	0.335	0.465	0.059	0.062	0.175	0.324	0.368	4,233	700	0.443
083NP	0.500	0.192	0.305	0.406	0.050	0.050	0.161	0.254	0.274	3,307	450	0.282
10BNP	0.625	0.380	0.400	0.580	0.067	0.067	0.200	0.388	0.455	5,997	880	0.618
12BNP	0.750	0.460	0.475	0.635	0.073	0.073	0.225	0.444	0.526	7,231	1,230	0.813
16BNP	1.000	0.670	0.625	0.830	0.125	0.157	0.326	0.713	0.776	17,108	2,800	1.787
20BNP	1.250	0.770	0.750	1.040	0.125	0.176	0.401	0.791	0.961	23,149	3,350	2.433
24BNP	1.500	1.000	1.000	1.315	0.189	0.236	0.576	1.066	1.267	39,683	5,650	4.737
28BNP	1.750	1.220	1.100	1.460	0.236	0.287	0.626	1.474	1.297	57,200	7,920	6.84
32BNP	2.000	1.220	1.150	1.665	0.236	0.276	0.701	1.502	1.305	63,580	8,440	6.59

ZINC-PLATED ANSI/ASME STANDARD



1. Zinc-plated roller chain provides **corrosion resistance** for applications with high humidity and salt water exposures or wash-downs.
2. All chain components are **heat-treated** to achieve maximum strength and greater wear resistance.
3. All PEER roller chain is **pre-loaded** during the manufacturing process to minimize initial elongation.
4. **Hot-dipped lubrication** ensures 100% lubrication of all chain components to extend wear life and reduce maintenance costs.

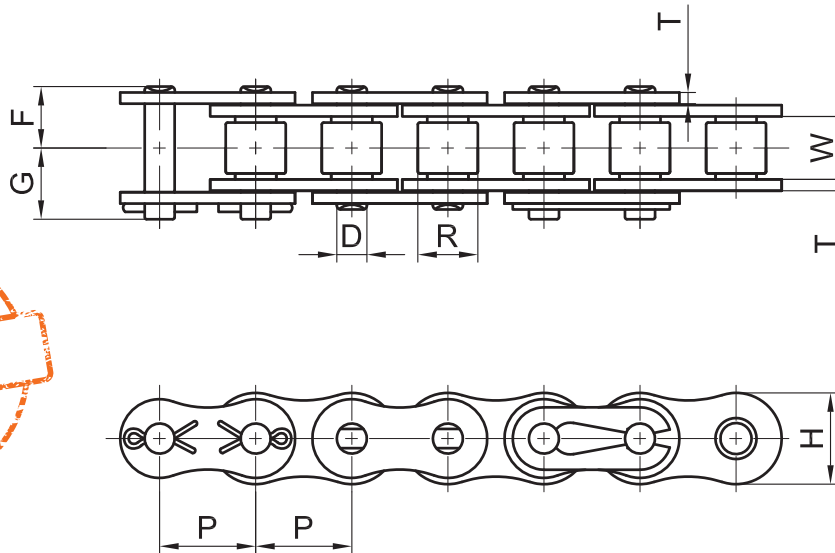

Dimensions: inch

Chain No.	Pitch P	Roller		Plate		Pin Dia. D	Overall Width		Avg. Ult. Tensile Strength (Lbs.)	Max. Working Load (Lbs.)	Avg. Weight Per Foot (Lbs.)
		Width	Dia.	Height	Thickness		F	G			
		W	R	H	T						
25ZP	0.250	0.125	0.130	0.228	0.030	0.091	0.154	0.185	1,036	165	0.087
35ZP	0.375	0.188	0.200	0.356	0.050	0.142	0.232	0.303	2,469	485	0.215
41ZP	0.500	0.250	0.306	0.390	0.050	0.142	0.263	0.334	2,866	529	0.276
40ZP	0.500	0.312	0.312	0.475	0.060	0.157	0.324	0.406	4,188	816	0.417
50ZP	0.625	0.375	0.400	0.594	0.080	0.200	0.400	0.488	6,834	1,400	0.679
60ZP	0.750	0.500	0.469	0.673	0.094	0.235	0.500	0.601	9,259	2,094	0.974
80ZP	1.000	0.625	0.625	0.950	0.125	0.313	0.650	0.803	17,636	3,307	1.714
100ZP	1.250	0.750	0.750	1.187	0.156	0.376	0.781	0.950	25,353	5,071	2.654
120ZP	1.500	1.000	0.875	1.425	0.187	0.437	1.005	1.174	34,392	6,834	3.790
140ZP	1.750	1.000	1.000	1.662	0.219	0.500	1.074	1.267	46,297	9,039	4.959
160ZP	2.000	1.250	1.125	1.900	0.250	0.563	1.290	1.459	57,761	11,905	6.317

ZINC-PLATED ANSI/ASME STANDARD DOUBLE PITCH A TYPE



1. Designed for **low speed** and long distance **drive applications**.
2. Zinc-plated roller chain provides **corrosion resistance** for applications with high humidity and salt water exposures or wash-downs.
3. All PEER roller chain is **pre-loaded** during the manufacturing process to minimize initial elongation.
4. **Hot-dipped lubrication** ensures 100% lubrication of all chain components to extend wear life and reduce maintenance costs.

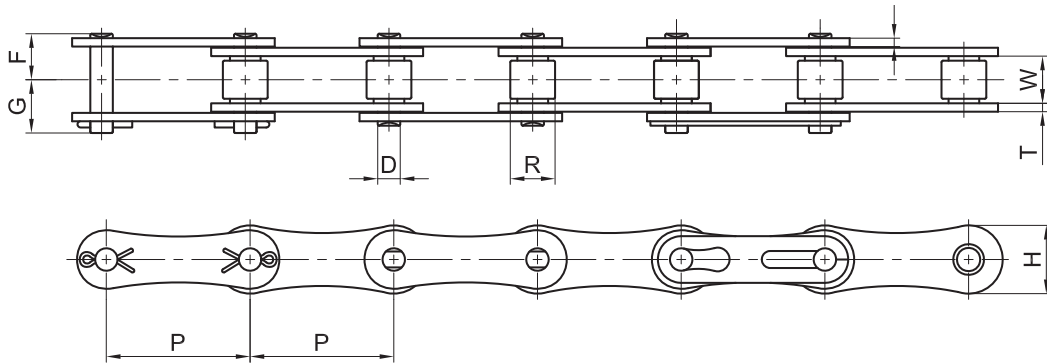

Dimensions: inch

Chain No.	Pitch	Roller		Plate		Pin Dia.	Overall Width		Avg. Ult. Tensile Strength (Lbs.)	Max. Working Load (Lbs.)	Avg. Weight Per Foot (Lbs.)
		Width	Dia.	Height	Thickness		F	G			
	P	W	R	H	T	D	F	G			
A2040ZP	1.000	0.312	0.312	0.475	0.060	0.157	0.324	0.406	4,189	529	0.276
A2042ZP	1.000	0.312	0.625	0.475	0.060	0.157	0.324	0.406	4,189	529	0.276
A2050ZP	1.250	0.375	0.400	0.594	0.080	0.200	0.400	0.488	6,834	792	0.457
A2052ZP	1.250	0.375	0.750	0.594	0.080	0.200	0.400	0.488	6,834	353	0.457
A2060ZP	1.500	0.500	0.469	0.712	0.094	0.235	0.501	0.601	9,259	1,144	0.638
A2062ZP	1.500	0.500	0.875	0.712	0.094	0.235	0.501	0.601	9,259	794	0.638
A2080ZP	2.000	0.625	0.625	0.950	0.125	0.313	0.650	0.803	17,637	1,936	1.176
A2082ZP	2.000	0.625	1.125	0.950	0.125	0.313	0.650	0.803	17,637	1,146	1.176

ZINC-PLATED ANSI/ASME STANDARD DOUBLE PITCH C TYPE



1. Designed for **low speed** and long distance **conveyor applications**.
2. Zinc-plated roller chain provides **corrosion resistance** for applications with high humidity and salt water exposures or wash-downs.
3. All PEER roller chain is **pre-loaded** during the manufacturing process to minimize initial elongation.
4. **Hot-dipped lubrication** ensures 100% lubrication of all chain components to extend wear life and reduce maintenance costs.

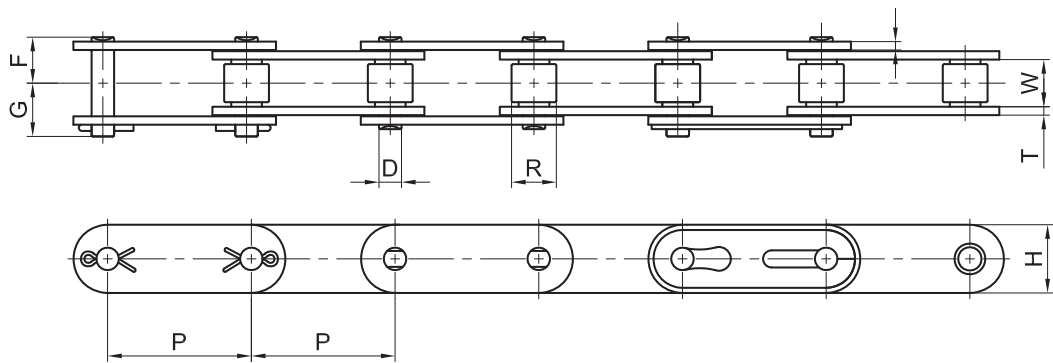

Dimensions: inch

Chain No.	Pitch P	Roller		Plate		Pin Dia. D	Overall Width		Avg. Ult. Tensile Strength (Lbs.)	Max. Working Load (Lbs.)	Avg. Weight Per Foot (Lbs.)
		Width W	Dia. R	Height H	Thickness T		F	G			
C2040ZP	1.000	0.312	0.312	0.475	0.060	0.157	0.324	0.406	4,189	529	0.316
C2042ZP	1.000	0.312	0.625	0.475	0.060	0.157	0.324	0.406	4,189	529	0.558
C2050ZP	1.250	0.375	0.400	0.594	0.080	0.200	0.400	0.488	6,834	794	0.538
C2052ZP	1.250	0.375	0.750	0.594	0.080	0.200	0.400	0.488	6,834	794	0.853
C2060ZP	1.500	0.500	0.469	0.712	0.094	0.235	0.501	0.601	9,259	1,146	0.759
C2060HWP	1.500	0.500	0.469	0.712	0.125	0.235	0.567	0.606	12,125	1,235	0.947
C2062HWP	1.500	0.500	0.875	0.712	0.125	0.235	0.567	0.606	12,125	1,235	1.431
C2080HWP	2.000	0.625	0.625	0.950	0.156	0.313	0.715	0.888	20,503	2,116	1.599
C2082HWP	2.000	0.625	1.125	0.950	0.156	0.313	0.715	0.888	20,503	2,116	2.318
C2100HWP	2.500	0.750	0.750	1.187	0.187	0.376	0.860	0.998	30,865	3,263	2.459
C2102HWP	2.500	0.750	1.562	1.187	0.187	0.376	0.860	0.998	30,865	3,263	3.944
C2120HWP	3.000	1.000	0.875	1.369	0.219	0.437	1.072	1.265	40,345	4,409	3.481
C2122HWP	3.000	1.000	1.750	1.369	0.219	0.437	1.072	1.265	40,345	4,409	5.436
C2160HWP	4.000	1.250	1.125	1.900	0.281	0.562	1.339	1.546	69,446	7,408	5.745
C2162HWP	4.000	1.250	2.250	1.900	0.281	0.562	1.339	1.546	69,446	7,408	8.729

ZINC-PLATED ISO BRITISH METRIC STANDARD



1. Zinc-plated roller chain provides **corrosion resistance** for applications with high humidity and salt water exposures or wash-downs.
2. All chain components are **heat-treated** to achieve maximum strength and greater wear resistance.
3. All PEER roller chain is **pre-loaded** during the manufacturing process to minimize initial elongation.
4. **Hot-dipped lubrication** ensures 100% lubrication of all chain components to extend wear life and reduce maintenance costs.

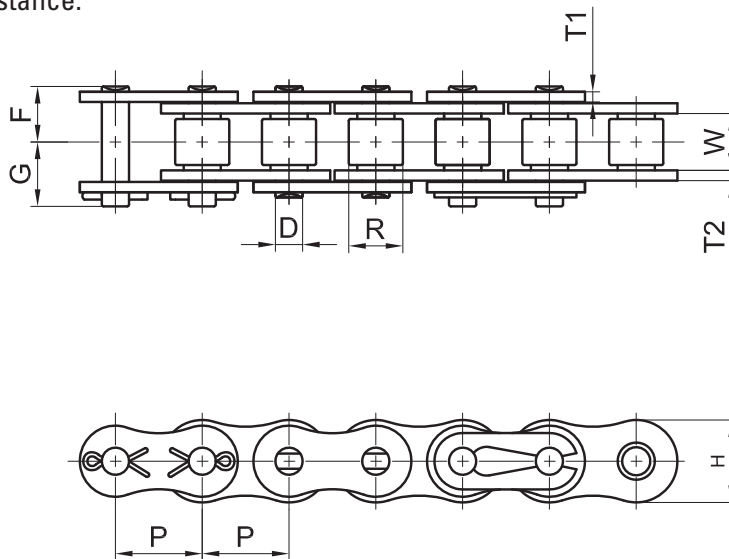

Dimensions: inch

Chain No.	Pitch P	Roller		Plate		Pin Dia. D	Overall Width		Avg. Ult. Tensile Strength (Lbs.)	Max. Working Load (Lbs.)	Avg. Weight Per Foot (Lbs.)	
		Width W	Dia. R	Height H	Thickness T1 T2		F	G				
04BZP	0.236	0.110	0.157	0.197	0.024	0.024	0.073	0.132	0.175	728	132	0.087
05BZP	0.315	0.118	0.197	0.280	0.031	0.031	0.091	0.154	0.185	1,280	243	0.108
06BZP	0.375	0.225	0.250	0.325	0.039	0.050	0.129	0.241	0.279	2,383	397	0.276
08BZP	0.500	0.305	0.335	0.465	0.059	0.062	0.175	0.324	0.368	4,236	883	0.443
083ZP	0.500	0.192	0.305	0.406	0.050	0.050	0.161	0.254	0.274	3,310	552	0.282
10BZP	0.625	0.380	0.400	0.580	0.067	0.067	0.200	0.388	0.455	6,001	1,103	0.618
12BZP	0.750	0.460	0.475	0.635	0.073	0.073	0.225	0.444	0.526	7,237	1,544	0.813
16BZP	1.000	0.670	0.625	0.830	0.125	0.157	0.326	0.713	0.776	17,122	3,530	1.787
20BZP	1.250	0.770	0.750	1.040	0.125	0.176	0.401	0.791	0.961	23,167	4,192	2.433
24BZP	1.500	1.000	1.000	1.315	0.189	0.236	0.576	1.066	1.267	39,716	7,061	4.737
28BZP	1.750	1.220	1.100	1.460	0.236	0.287	0.626	1.474	1.297	57,367	9,929	6.437
32BZP	2.000	1.220	1.150	1.665	0.236	0.276	0.701	1.502	1.305	63,766	10,591	6.196

STAINLESS STEEL SS

ANSI/ASME STANDARD

SINGLE STRAND



1. Provides **exceptional corrosion resistance** and commonly used in applications with high humidity, outdoor environments, and saltwater applications.
2. Commonly used in **food processing** or applications where chain is exposed to **chemicals**.
3. Used in **high** and **low** temperature environments.
4. All PEER roller chain is **pre-loaded** during the manufacturing process to minimize initial elongation.

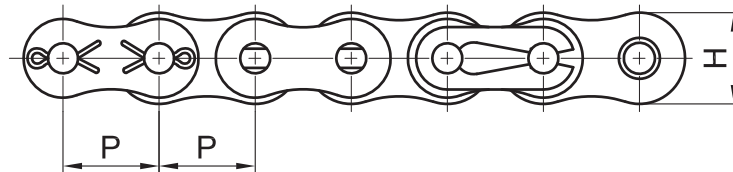
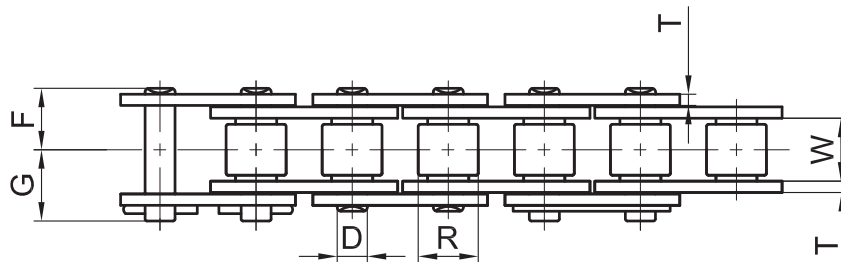

Dimensions: inch

Chain No.	Pitch P	Roller		Plate		Pin Dia. D	Overall Width		Avg. Ult. Tensile Strength (Lbs.)	Max. Working Load (Lbs.)	Avg. Weight Per Foot (Lbs.)
		Width W	Dia. R	Height H	Thickness T		F	G			
25SS	0.250	0.125	0.130	0.228	0.030	0.091	0.154	0.185	473	18	0.090
35SS	0.375	0.188	0.200	0.356	0.050	0.142	0.232	0.277	1,755	65	0.240
41SS	0.500	0.250	0.306	0.390	0.050	0.142	0.263	0.334	1,600	90	0.290
40SS	0.500	0.312	0.312	0.475	0.060	0.157	0.324	0.406	2,880	108	0.420
50SS	0.625	0.375	0.400	0.594	0.080	0.200	0.400	0.488	4,500	171	0.710
60SS	0.750	0.500	0.469	0.712	0.094	0.235	0.501	0.601	5,940	225	0.970
80SS	1.000	0.625	0.625	0.950	0.125	0.313	0.650	0.803	10,710	405	1.680
100SS	1.250	0.750	0.750	1.187	0.156	0.376	0.781	0.950	12,600	473	2.540
120SS	1.500	1.000	0.875	1.425	0.187	0.437	1.005	1.174	17,775	675	3.790

STAINLESS STEEL SS ANSI/ASME STANDARD MULTI STRAND



1. Provides **exceptional corrosion resistance** and commonly used in applications with high humidity, outdoor environments, and saltwater applications.
2. Commonly used in **food processing** or applications where chain is exposed to **chemicals**.
3. Used in **high** and **low** temperature environments.
4. All PEER roller chain is **pre-loaded** during the manufacturing process to minimize initial elongation.

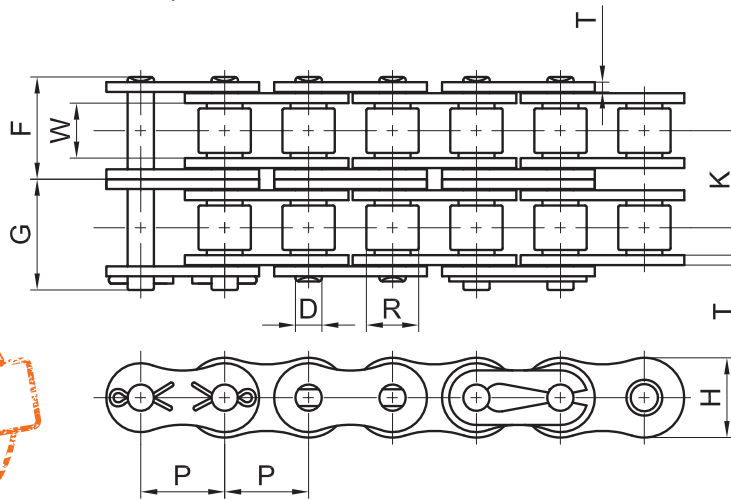

Dimensions: inch

Chain No.	Pitch P	Roller		Plate		Pin Dia. D	Overall Width		Transverse Pitch K	Avg. Ult. Tensile Strength (Lbs.)	Max. Working Load (Lbs.)	Avg. Weight Per Foot (Lbs.)
		Width	Dia.	Height	Thickness		F	G				
		W	R	H	T							
25-2SS	0.250	0.125	0.130	0.228	0.030	0.091	0.280	0.311	0.252	945	36	0.168
25-3SS	0.250	0.125	0.130	0.228	0.030	0.091	0.415	0.446	0.252	1,360	49	0.29
35-2SS	0.375	0.188	0.200	0.356	0.050	0.142	0.441	0.469	0.399	3,510	130	0.460
35-3SS	0.375	0.188	0.200	0.356	0.050	0.142	0.633	0.704	0.399	3,860	139	0.75
40-2SS	0.500	0.312	0.312	0.475	0.060	0.157	0.608	0.690	0.566	5,760	216	0.850
40-3SS	0.500	0.312	0.312	0.475	0.060	0.157	0.890	0.975	0.566	6,000	216	1.36
50-2SS	0.625	0.375	0.400	0.594	0.080	0.200	0.755	0.850	0.713	9,000	342	1.370
50-3SS	0.625	0.375	0.400	0.594	0.080	0.200	1.113	1.207	0.713	11,420	411	2.21
60-2SS	0.750	0.500	0.469	0.712	0.094	0.235	0.949	1.055	0.897	11,880	450	2.040
60-3SS	0.750	0.500	0.469	0.712	0.094	0.235	1.400	1.506	0.897	13,860	499	3.24
80-2SS	1.000	0.625	0.625	0.950	0.125	0.313	1.224	1.386	1.153	21,420	910	3.410
80-3SS	1.000	0.625	0.625	0.950	0.125	0.313	1.799	1.965	1.153	26,100	940	5.64
100-2SS	1.250	0.750	0.750	1.187	0.156	0.376	1.502	1.655	1.408	25,200	945	5.282
100-3SS	1.250	0.750	0.750	1.187	0.156	0.376	2.224	2.338	1.408	33,920	1,221	8.41
120-2SS	1.500	1.000	0.875	1.425	0.187	0.437	1.895	2.060	1.789	25,200	1,350	8.36
120-3SS	1.500	1.000	0.875	1.425	0.187	0.437	2.773	2.974	1.789	52,460	1,889	12.52

STAINLESS STEEL SS

ANSI/ASME STANDARD

HEAVY H SERIES



1. Provides **exceptional corrosion resistance** and commonly used in applications with high humidity, outdoor environments, and saltwater applications.
2. Commonly used in **food processing** or applications where chain is exposed to **chemicals**.
3. Used in **high** and **low** temperature environments.
4. All PEER roller chain is **pre-loaded** during the manufacturing process to minimize initial elongation.

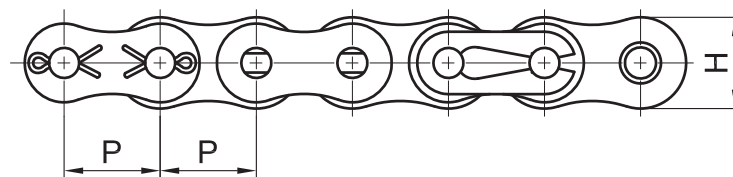
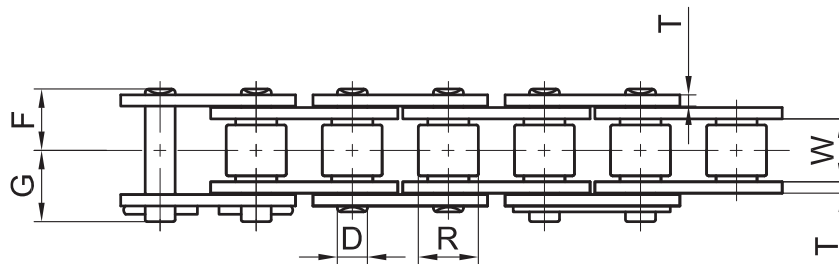

Dimensions: inch

Chain No.	Pitch P	Roller		Plate		Pin Dia. D	Overall Width		Avg. Ult. Tensile Strength (Lbs.)	Max. Working Load (Lbs.)	Avg. Weight Per Foot (Lbs.)
		Width W	Dia. R	Height H	Thickness T		F	G			
40HSS	0.500	0.312	0.312	0.480	0.080	0.157	0.361	0.456	2,688	97	0.500
50HSS	0.625	0.375	0.400	0.573	0.094	0.200	0.435	0.474	4,771	172	0.766
60HSS	0.750	0.500	0.469	0.765	0.125	0.235	0.567	0.618	5,667	204	1.163
80HSS	1.000	0.625	0.625	0.956	0.156	0.313	0.715	0.793	10,237	369	1.996
100HSS	1.250	0.750	0.750	1.146	0.187	0.376	0.860	0.998	14,918	537	3.017
120HSS	1.500	1.000	0.875	1.464	0.219	0.437	1.072	1.265	22,019	793	4.207

STAINLESS STEEL SS

ANSI/ASME STANDARD

DOUBLE PITCH

A TYPE



1. Provides **exceptional corrosion resistance** and commonly used in applications with high humidity, outdoor environments, and saltwater applications.
2. Commonly used in **food processing** or applications where chain is exposed to **chemicals**.
3. Used in **high** and **low** temperature environments.
4. All PEER roller chain is **pre-loaded** during the manufacturing process to minimize initial elongation.

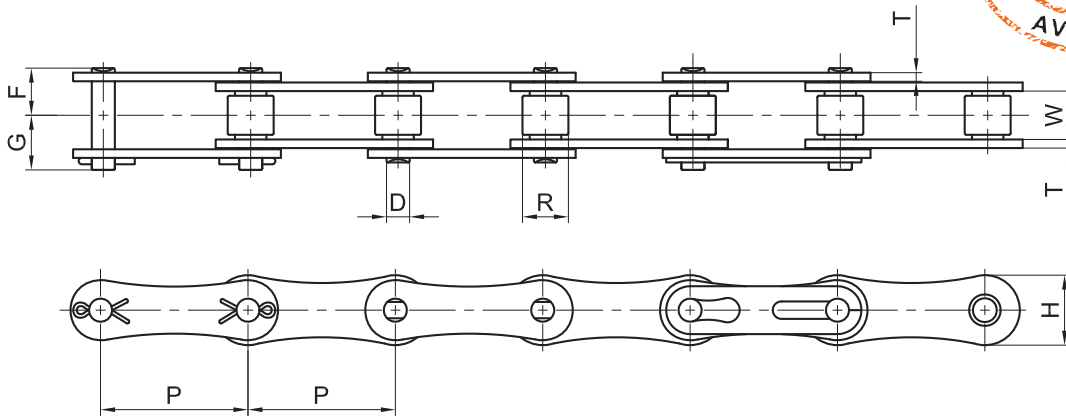

Dimensions: inch

Chain No.	Pitch	Roller		Plate		Pin Dia.	Overall Width		Avg. Ult. Tensile Strength (Lbs.)	Max. Working Load (Lbs.)	Avg. Weight Per Foot (Lbs.)
		Width	Dia.	Height	Thickness		F	G			
	P	W	R	H	T	D	F	G			
A2040SS	1.000	0.312	0.312	0.475	0.060	0.157	0.324	0.406	2,880	108	0.276
A2042SS	1.000	0.312	0.625	0.475	0.060	0.157	0.324	0.406	2,688	430	0.276
A2050SS	1.250	0.375	0.400	0.594	0.080	0.200	0.400	0.488	4,500	171	0.457
A2052SS	1.250	0.375	0.750	0.594	0.080	0.200	0.400	0.488	4,500	171	0.457
A2060SS	1.500	0.500	0.469	0.712	0.094	0.235	0.501	0.601	5,940	225	0.638
A2062SS	1.500	0.500	0.875	0.712	0.094	0.235	0.501	0.601	5,940	225	0.638
A2080SS	2.000	0.625	0.625	0.950	0.125	0.313	0.650	0.803	10,710	405	1.176
A2082SS	2.000	0.625	1.125	0.950	0.125	0.313	0.650	0.803	10,710	405	1.176

STAINLESS STEEL SS

ANSI/ASME STANDARD

DOUBLE PITCH

C TYPE



1. Provides **exceptional corrosion resistance** and commonly used in applications with high humidity, outdoor environments, and saltwater applications.
2. Commonly used in **food processing** or applications where chain is exposed to **chemicals**.
3. Used in **high** and **low** temperature environments.
4. All PEER roller chain is **pre-loaded** during the manufacturing process to minimize initial elongation.

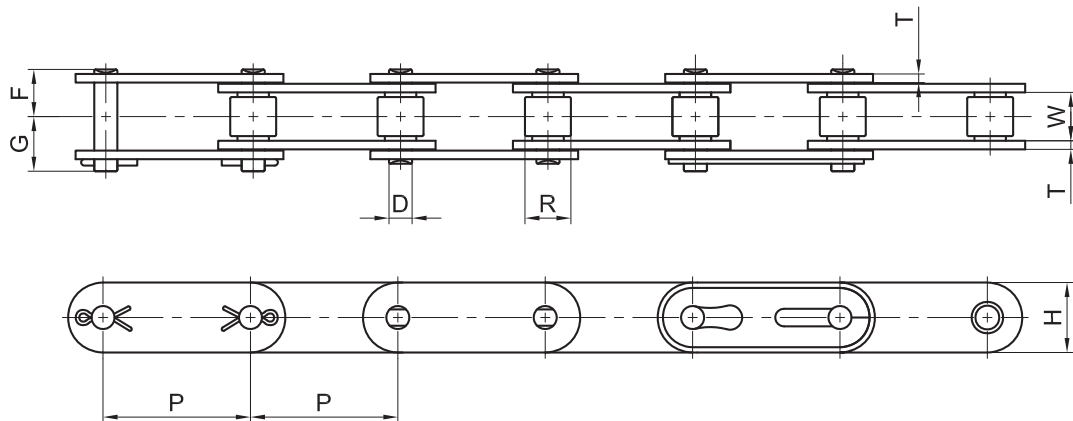

Dimensions: inch

Chain No.	Pitch P	Roller		Plate		Pin Dia. D	Overall Width		Avg. Ult. Tensile Strength (Lbs.)	Max. Working Load (Lbs.)	Avg. Weight Per Foot (Lbs.)
		Width W	Dia. R	Height H	Thickness T		F	G			
C2040SS	1.000	0.312	0.312	0.475	0.060	0.157	0.324	0.406	2,880	108	0.316
C2042SS	1.000	0.312	0.625	0.475	0.060	0.157	0.324	0.406	2,880	108	0.558
C2050SS	1.250	0.375	0.400	0.594	0.080	0.200	0.400	0.488	4,500	171	0.538
C2052SS	1.250	0.375	0.750	0.594	0.080	0.200	0.400	0.488	4,500	171	0.853
C2060SS	1.500	0.500	0.469	0.712	0.094	0.235	0.501	0.601	5,940	225	0.759
C2060HSS	1.500	0.500	0.469	0.712	0.125	0.235	0.567	0.606	6,821	259	0.947
C2062HSS	1.500	0.500	0.875	0.712	0.125	0.235	0.567	0.606	6,821	259	1.431
C2080HSS	2.000	0.625	0.625	0.950	0.156	0.313	0.715	0.888	11,995	453	1.599
C2082HSS	2.000	0.625	1.125	0.950	0.156	0.313	0.715	0.888	11,995	453	2.318
C2100HSS	2.500	0.750	0.750	1.187	0.187	0.376	0.860	0.998	13,230	496	2.459
C2102HSS	2.500	0.750	1.562	1.187	0.187	0.376	0.860	0.998	13,230	496	3.944
C2120HSS	3.000	1.000	0.875	1.369	0.219	0.437	1.072	1.265	18,663	708	3.481
C2122HSS	3.000	1.000	1.750	1.369	0.219	0.437	1.072	1.265	18,663	708	5.436

STAINLESS STEEL SS

ISO BRITISH METRIC STANDARD



1. Provides **exceptional corrosion resistance** and commonly used in applications with high humidity, outdoor environments, and saltwater applications.
2. Commonly used in **food processing** or applications where chain is exposed to **chemicals**.
3. Used in **high** and **low** temperature environments.
4. All PEER roller chain is **pre-loaded** during the manufacturing process to minimize initial elongation.

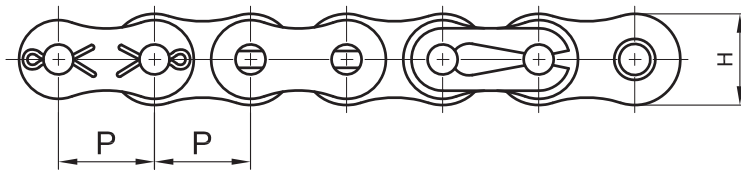
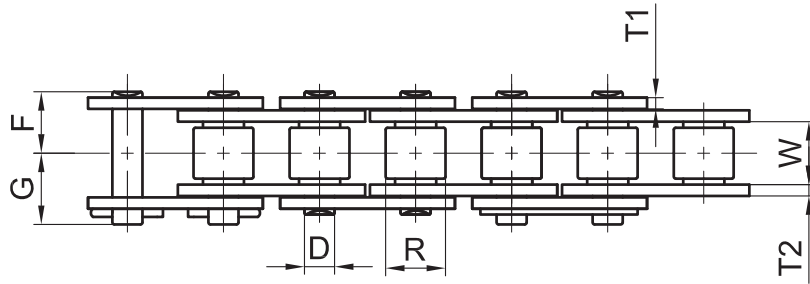

Dimensions: inch

Chain No.	Pitch P	Roller		Plate		Pin Dia. D	Overall Width		Avg. Ult. Tensile Strength (Lbs.)	Max. Working Load (Lbs.)	Avg. Weight Per Foot (Lbs.)	
		Width W	Dia. R	Height H	Thickness T1 T2		F	G				
04BSS	0.236	0.110	0.157	0.197	0.024	0.024	0.073	0.132	0.175		0.087	
05BSS	0.315	0.118	0.197	0.280	0.031	0.031	0.091	0.154	0.185	941	34	0.108
06BSS	0.375	0.225	0.250	0.325	0.039	0.050	0.129	0.241	0.279	1,277	46	0.276
08BSS	0.500	0.305	0.335	0.465	0.059	0.062	0.175	0.324	0.368	2,733	98	0.443
083SS	0.500	0.192	0.305	0.406	0.050	0.050	0.161	0.254	0.274			0.282
10BSS	0.625	0.380	0.400	0.580	0.067	0.067	0.200	0.388	0.455	3,402	122	0.618
12BSS	0.750	0.460	0.475	0.635	0.073	0.073	0.225	0.444	0.574	3,717	134	0.813
16BSS	1.000	0.670	0.625	0.830	0.125	0.157	0.326	0.713	0.776	9,807	353	1.787
20BSS	1.250	0.770	0.750	1.040	0.125	0.176	0.401	0.791	0.961	13,503	486	2.433
24BSS	1.500	1.000	1.000	1.315	0.189	0.236	0.576	1.066	1.267	24,276	874	4.737

STAINLESS STEEL MSS

ANSI/ASME STANDARD



1. Provides **superior corrosion resistance** for chemical and acidic environments, especially where chlorine and sulfur are present.
2. Commonly used in **food contact** or **low magnetic permeable** applications.
3. Used in **high** and **low** temperature environments.
4. All PEER roller chain is **pre-loaded** during the manufacturing process to minimize initial elongation.

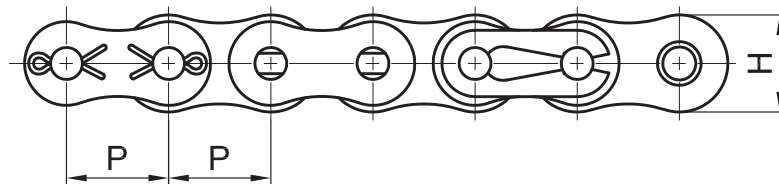
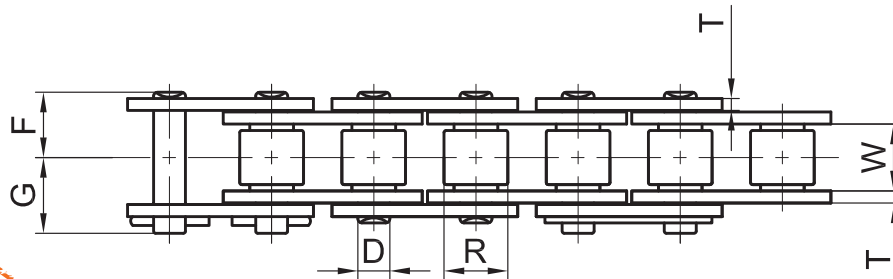

Dimensions: inch

Chain No.	Pitch P	Roller		Plate		Pin Dia. D	Overall Width		Avg. Ult. Tensile Strength (Lbs.)	Max. Working Load (Lbs.)	Avg. Weight Per Foot (Lbs.)
		Width W	Dia. R	Height H	Thickness T		F	G			
25MSS	0.250	0.125	0.130	0.228	0.030	0.091	0.154	0.185	473	18	0.090
35MSS	0.375	0.188	0.200	0.356	0.050	0.142	0.232	0.277	1,755	65	0.240
41MSS	0.500	0.250	0.306	0.390	0.050	0.142	0.263	0.334	1,600	90	0.290
40MSS	0.500	0.312	0.312	0.475	0.060	0.157	0.324	0.406	2,880	108	0.420
50MSS	0.625	0.375	0.400	0.594	0.080	0.200	0.400	0.488	4,500	171	0.710
60MSS	0.750	0.500	0.469	0.712	0.094	0.235	0.501	0.601	5,940	225	0.970
80MSS	1.000	0.625	0.625	0.950	0.125	0.313	0.650	0.803	10,710	405	1.680
100MSS	1.250	0.750	0.750	1.187	0.156	0.376	0.781	0.950	12,600	473	2.540
120MSS	1.500	1.000	0.875	1.425	0.187	0.437	1.005	1.174	17,775	675	3.790

STAINLESS STEEL MSS ANSI/ASME STANDARD DOUBLE PITCH A TYPE



1. Provides **superior corrosion resistance** for chemical and acidic environments, especially where chlorine and sulfur are present.
2. Commonly used in **food contact** or **low magnetic permeable** applications.
3. Used in **high** and **low** temperature environments.
4. All PEER roller chain is **pre-loaded** during the manufacturing process to minimize initial elongation.

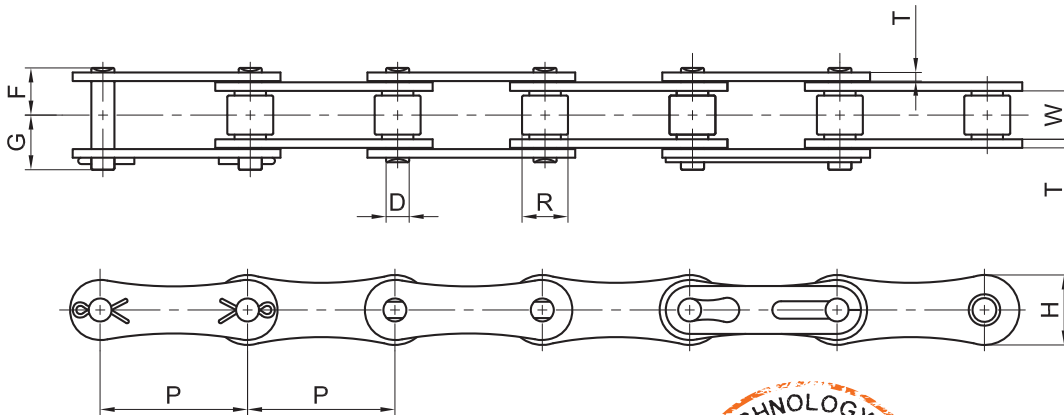

Dimensions: inch

Chain No.	Pitch P	Roller		Plate		Pin Dia. D	Overall Width		Avg. Ult. Tensile Strength (Lbs.)	Max. Working Load (Lbs.)	Avg. Weight Per Foot (Lbs.)
		Width W	Dia. R	Height H	Thickness T		F	G			
A2040MSS	1.000	0.312	0.312	0.475	0.060	0.157	0.324	0.406	2,880	108	0.276
A2042MSS	1.000	0.312	0.625	0.475	0.060	0.157	0.324	0.406	2,688	430	0.276
A2050MSS	1.250	0.375	0.400	0.594	0.080	0.200	0.400	0.488	4,500	171	0.457
A2052MSS	1.250	0.375	0.750	0.594	0.080	0.200	0.400	0.488	4,500	171	0.457
A2060MSS	1.500	0.500	0.469	0.712	0.094	0.235	0.501	0.601	5,940	225	0.638
A2062MSS	1.500	0.500	0.875	0.712	0.094	0.235	0.501	0.601	5,940	225	0.638
A2080MSS	2.000	0.625	0.625	0.950	0.125	0.313	0.650	0.803	10,710	405	1.176
A2082MSS	2.000	0.625	1.125	0.950	0.125	0.313	0.650	0.803	10,710	405	1.176

STAINLESS STEEL MSS

ANSI/ASME STANDARD

DOUBLE PITCH

C TYPE



1. Provides **superior corrosion resistance** for chemical and acidic environments, especially where chlorine and sulfur are present.
2. Commonly used in **food contact** or **low magnetic permeable** applications.
3. Used in **high** and **low** temperature environments.
4. All PEER roller chain is **pre-loaded** during the manufacturing process to minimize initial elongation.

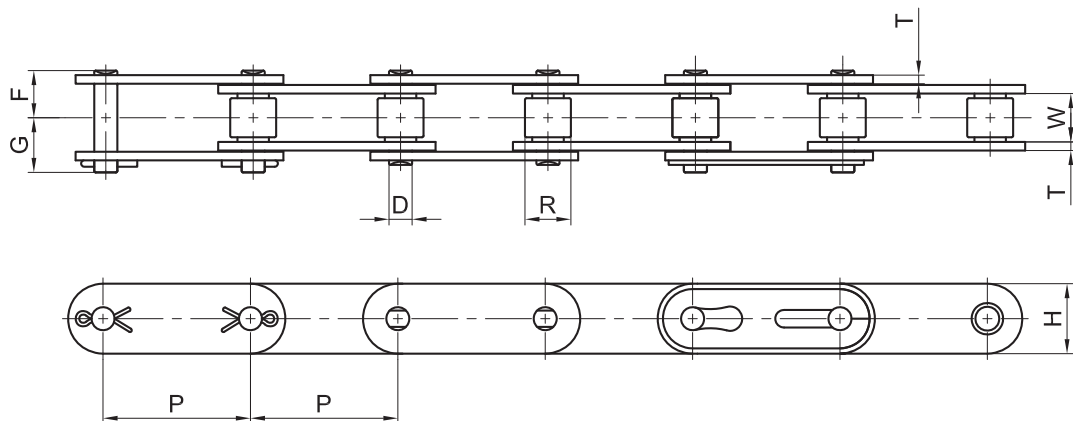

Dimensions: inch

Chain No.	Pitch P	Roller		Plate		Pin Dia. D	Overall Width		Avg. Ult. Tensile Strength (Lbs.)	Max. Working Load (Lbs.)	Avg. Weight Per Foot (Lbs.)
		Width W	Dia. R	Height H	Thickness T		F	G			
C2040MSS	1.000	0.312	0.312	0.475	0.060	0.157	0.324	0.406	2,880	108	0.316
C2042MSS	1.000	0.312	0.625	0.475	0.060	0.157	0.324	0.406	2,880	108	0.558
C2050MSS	1.250	0.375	0.400	0.594	0.080	0.200	0.400	0.488	4,500	171	0.538
C2052MSS	1.250	0.375	0.750	0.594	0.080	0.200	0.400	0.488	4,500	171	0.853
C2060MSS	1.500	0.500	0.469	0.712	0.094	0.235	0.501	0.601	5,940	225	0.759
C2060HMSS	1.500	0.500	0.469	0.712	0.125	0.235	0.567	0.606	6,821	259	0.947
C2062HMSS	1.500	0.500	0.875	0.712	0.125	0.235	0.567	0.606	6,821	259	1.431
C2080HMSS	2.000	0.625	0.625	0.950	0.156	0.313	0.715	0.888	11,995	453	1.599
C2082HMSS	2.000	0.625	1.125	0.950	0.156	0.313	0.715	0.888	11,995	453	2.318
C2100HMSS	2.500	0.750	0.750	1.187	0.187	0.376	0.860	0.998	13,230	496	2.459
C2102HMSS	2.500	0.750	1.562	1.187	0.187	0.376	0.860	0.998	13,230	496	3.944
C2120HMSS	3.000	1.000	0.875	1.369	0.219	0.437	1.072	1.265	18,663	708	3.481
C2122HMSS	3.000	1.000	1.750	1.369	0.219	0.437	1.072	1.265	18,663	708	5.436

STAINLESS STEEL PHSS ANSI/ASME STANDARD



1. Provides **exceptional corrosion resistance** for applications requiring higher working loads.
2. Working load of 600 series is **higher than** 304 and 316 series.
3. Used in **high** and **low** temperature environments.
4. All PEER roller chain is **pre-loaded** during the manufacturing process to minimize initial elongation.

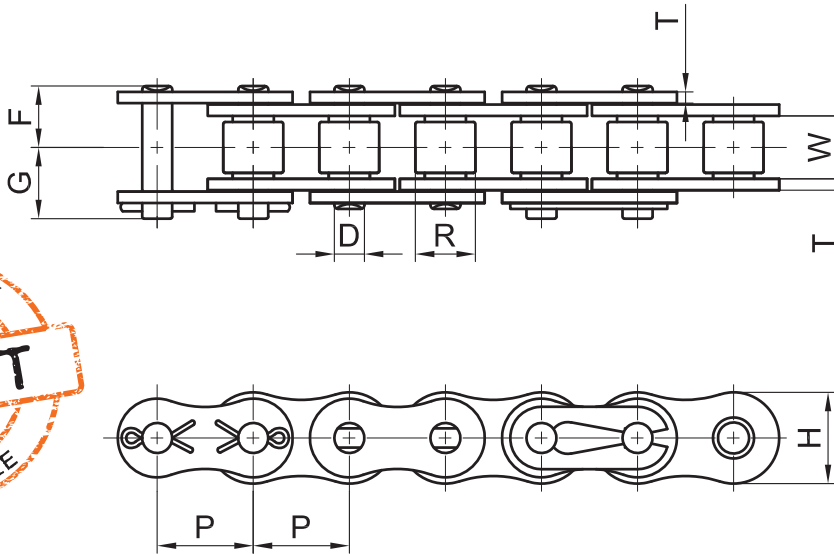

Dimensions: inch

Chain No.	Pitch P	Roller		Plate		Pin Dia. D	Overall Width		Avg. Ult. Tensile Strength (Lbs.)	Max. Working Load (Lbs.)	Avg. Weight Per Foot (Lbs.)
		Width W	Dia. R	Height H	Thickness T		F	G			
		25PHSS	0.250	0.125	0.130		0.228	0.030			
35PHSS	0.375	0.188	0.200	0.356	0.050	0.142	0.232	0.303	1,694	90	0.240
40PHSS	0.500	0.312	0.312	0.475	0.060	0.157	0.324	0.406	3,190	160	0.420
50PHSS	0.625	0.375	0.400	0.594	0.080	0.200	0.400	0.488	5,324	229	0.710
60PHSS	0.750	0.500	0.469	0.712	0.094	0.235	0.501	0.601	7,095	352	0.970
80PHSS	1.000	0.625	0.625	0.950	0.125	0.313	0.650	0.803	13,244	595	1.680
100PHSS	1.250	0.750	0.750	1.187	0.156	0.376	0.781	0.950	12,600	663	2.540
120PHSS	1.500	1.000	0.875	1.425	0.187	0.437	1.005	1.174	20,441	945	3.790

STAINLESS STEEL PHSS

ANSI/ASME STANDARD DOUBLE PITCH



1. Provides **exceptional corrosion resistance** for applications requiring higher working loads.
2. Working load of 600 series is **higher than** 304 and 316 series.
3. Used in **high** and **low** temperature environments.
4. All PEER roller chain is **pre-loaded** during the manufacturing process to minimize initial elongation.

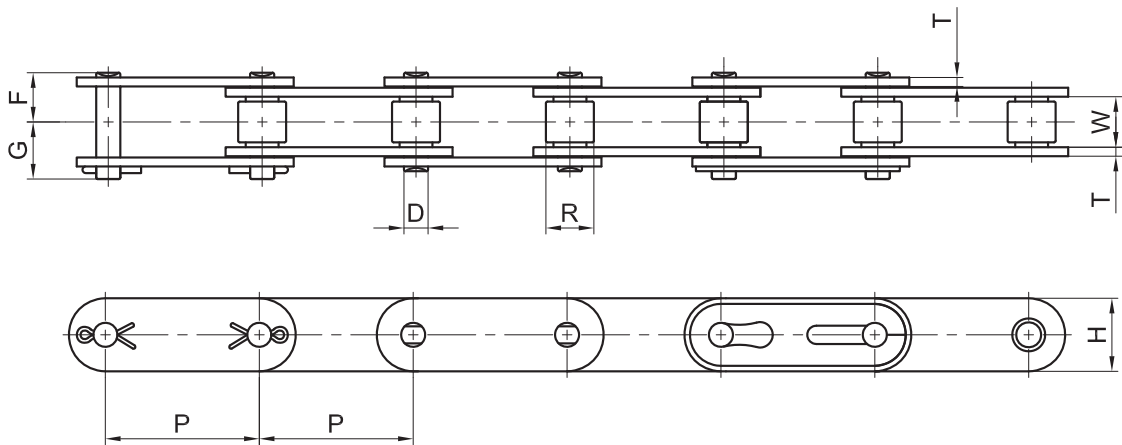

Dimensions: inch

Chain No.	Pitch P	Roller		Plate		Pin Dia. D	Overall Width		Avg. Ult. Tensile Strength (Lbs.)	Max. Working Load (Lbs.)	Avg. Weight Per Foot (Lbs.)
		Width	Dia.	Height	Thickness		F	G			
		W	R	H	T						
C2040PHSS	1.000	0.312	0.312	0.475	0.060	0.157	0.324	0.406	2,750	160	0.316
C2042PHSS	1.000	0.312	0.625	0.475	0.060	0.157	0.324	0.406	2,750	160	0.558
C2050PHSS	1.250	0.375	0.400	0.594	0.080	0.200	0.400	0.488	4,950	229	0.538
C2052PHSS	1.250	0.375	0.750	0.594	0.080	0.200	0.400	0.488	4,950	229	0.853
C2060PHSS	1.500	0.500	0.469	0.712	0.094	0.235	0.501	0.601	6,160	352	0.759
C2060HPHSS	1.500	0.500	0.469	0.712	0.125	0.235	0.567	0.606	6,600	380	0.947
C2062HPHSS	1.500	0.500	0.875	0.712	0.125	0.235	0.567	0.606	6,600	380	1.431
C2080HPHSS	2.000	0.625	0.625	0.950	0.156	0.313	0.715	0.888	11,440	629	1.599
C2082HPHSS	2.000	0.625	1.125	0.950	0.156	0.313	0.715	0.888	11,440	629	2.318

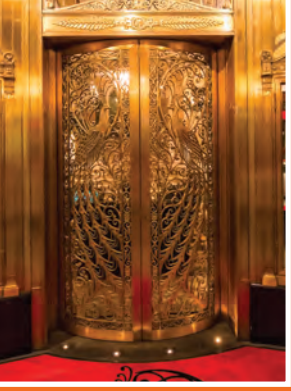

SELF LUBE

When there is an environment that is difficult to access or maintain, PEER Chain offers self-lubricating chain options. Our self-lubricating chain improves the lifecycle of equipment while minimizing maintenance costs associated with the cost of daily lubrication. Our PEER Chain self-lubricating chain is a suitable choice for both drive and conveyance applications.

SL Series chain incorporates oil impregnated sintered-bushing chain designed for challenging operating environments. The tensile strength of the SL Series is different than our ANSI/ASME standard roller chain.

SLB Series chain is the ideal choice for moist applications because the side plates and pins are coated. Unlike the SL Series, this chain offers the same tensile strength as our ANSI/ASME standard roller chain. This is the optimum choice for conveyance applications.

SLH Series chain provides the same maximum working load as our ANSI standard roller chain. While SLH Series chain provides the same features as SLB Series, it is the optimal choice for drive applications at low to moderate speeds.



Double Puzzle

LUYQTAI

--	--	--	--	--	--	--

6

TCUSMURROOTENSONSIL

--	--	--	--	--	--	--	--

8 16 11 12 13 1 7

--	--	--	--	--	--	--	--	--	--

9 10

EENUUYRPNIGNKO

--	--	--	--

--	--	--

3

--	--	--	--	--	--	--	--

15

RCRPAFNMOEE

--	--	--	--	--	--	--	--	--	--	--

14

4

PEPEOL

--	--	--	--	--	--

2

SOPSINA

--	--	--	--	--	--	--

5

W	
---	--

1

		V	
--	--	---	--

2 3 4

--	--	--

5 6 7

--	--	--	--	--	--	--	--	--

8 9 10 11 12 13 14 15 16

**At the beginning of each Escape Room, you will find a puzzle. Solve each puzzle to find the cryptic message in each Escape Room. Once you have completed the puzzles, visit our website (peerchain.com) and search for the discrete door and enter! Once you complete the form, what follows is all about our relationship with you!*

ANSI/ASME STANDARD SL SERIES



1. Maximizes chain life with **oil impregnated sintered bushings**.
2. A **rollerless** chain with bushing OD equivalent to the OD of standard roller chain rollers.
3. Ideal for applications where it is difficult to access or maintain chain.
4. Our PEER Chain self-lube chain is a suitable choice for both **drive and conveyance** applications.

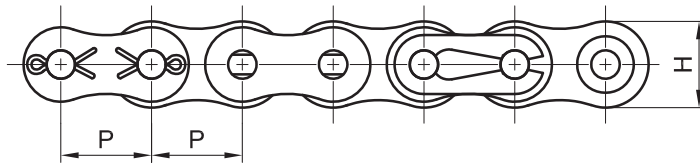
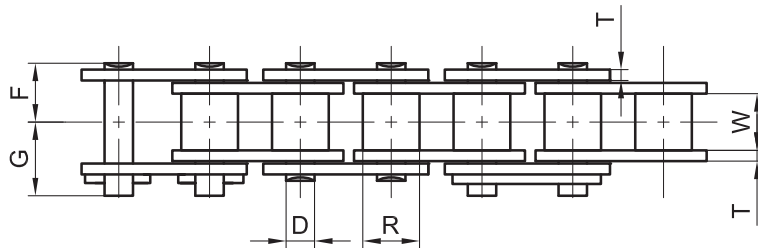

Dimensions: inch

Chain No.	Pitch P	Roller		Plate		Pin Dia. D	Overall Width		Avg. Ult. Tensile Strength (Lbs.)	Avg. Weight Per Foot (Lbs.)
		Width	Dia.	Height	Thickness		F	G		
		W	R	H	T					
35 SL	0.375	0.188	0.200	0.356	0.050	0.118	0.232	0.277	2,310	0.21
40 SL	0.500	0.312	0.312	0.475	0.060	0.157	0.324	0.406	2,970	0.42
50 SL	0.625	0.375	0.400	0.594	0.080	0.200	0.400	0.488	4,620	0.69
60 SL	0.750	0.500	0.469	0.712	0.094	0.235	0.501	0.601	6,380	0.97
80 SL	1.000	0.625	0.625	0.950	0.125	0.313	0.650	0.803	11,440	1.74
100 SL	1.250	0.750	0.750	1.187	0.156	0.376	0.781	0.950	18,480	2.57

ANSI/ASME STANDARD DOUBLE PITCH SL SERIES



1. Maximizes chain life with **oil impregnated sintered bushings**.
2. A **rollerless** chain with bushing OD equivalent to the OD of standard roller chain rollers.
3. Ideal for applications where it is difficult to access or maintain chain.
4. Our PEER Chain self-lube chain is a suitable choice for both **drive and conveyance** applications.

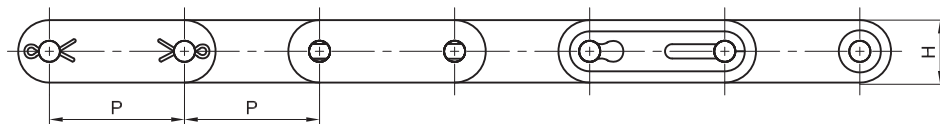
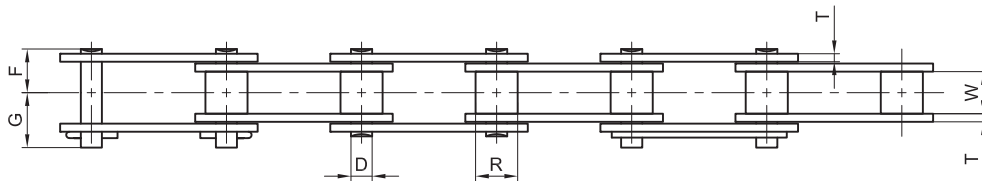

Dimensions: inch

Chain No.	Pitch P	Roller		Plate		Pin Dia. D	Overall Width		Avg. Ult. Tensile Strength (Lbs.)	Avg. Weight Per Foot (Lbs.)
		Width W	Dia. R	Height H	Thickness T		F	G		
C2040 SL	1.000	0.312	0.312	0.463	0.060	0.157	0.324	0.406	2,860	0.33
C2042 SL	1.000	0.312	0.625	0.463	0.060	0.157	0.324	0.406	2,860	0.58
C2050 SL	1.250	0.375	0.400	0.594	0.080	0.200	0.400	0.488	4,620	0.54
C2052 SL	1.250	0.375	0.750	0.594	0.080	0.200	0.400	0.488	4,620	0.89
C2060H SL	1.500	0.500	0.469	0.712	0.125	0.235	0.567	0.618	8,360	0.94
C2062H SL	1.500	0.500	0.875	0.712	0.125	0.235	0.567	0.618	8,360	1.47
C2080H SL	2.000	0.625	0.625	0.950	0.156	0.313	0.720	0.793	14,520	1.68
C2082H SL	2.000	0.625	1.125	0.950	0.156	0.313	0.720	0.793	14,520	2.64
C2102H SL	2.500	0.750	1.562	1.187	0.187	0.376	0.860	0.997	30,800	4.13
C2122H SL	3.000	1.000	1.750	1.425	0.219	0.437	1.072	1.265	40,260	5.69

ANSI/ASME STANDARD SLB SERIES



1. Features assembled rollers, **oil impregnated sintered bushings**, and **phosphate coated** roller link plates with nickel-plated pins.
2. SLB series chains are designed with the same **tensile strength** as ANSI/ASME standard chain and provide **greater resistance** to corrosion and wear.
3. Ideal for applications where it is difficult to access or maintain chain and a greater tensile strength is required.
4. SLB series chain is the **optimum choice** for conveyance applications.

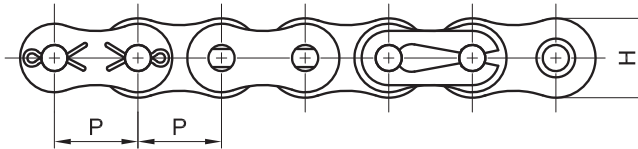
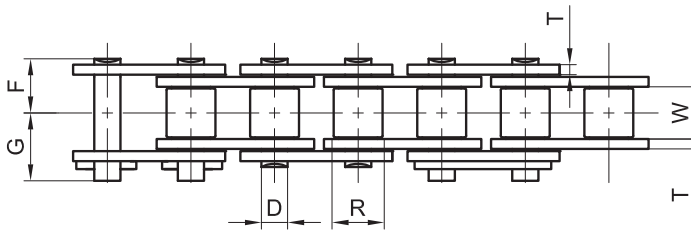

Dimensions: inch

Chain No.	Pitch	Roller		Plate		Pin Dia.	Overall Width		Avg. Ult. Tensile Strength (Lbs.)	Max. Working Load (Lbs.)	Avg. Weight Per Foot (Lbs.)
		Width	Dia.	Height	Thickness		F	G			
	P	W	R	H	T	D	F	G			
40 SLB	0.500	0.312	0.312	0.475	0.060	0.157	0.406	0.324	4,180	816	0.52
50 SLB	0.625	0.375	0.400	0.622	0.080	0.200	0.488	0.400	6,820	1,400	0.75
60 SLB	0.750	0.500	0.469	0.712	0.094	0.235	0.601	0.501	9,240	2,094	1.04
80 SLB	0.800	0.625	0.625	0.950	0.125	0.313	0.803	0.650	17,600	3,307	1.90
100 SLB	1.000	0.750	0.750	1.187	0.156	0.376	0.950	0.781	25,300	5,071	2.87
120 SLB	1.250	1.000	0.875	1.425	0.187	0.437	1.174	1.005	34,320	6,834	4.70
140 SLB	1.750	1.000	1.000	1.662	0.219	0.500	1.267	1.074	46,200	9,039	5.39
160 SLB	2.000	1.250	1.125	1.900	0.250	0.563	1.459	1.290	57,860	11,905	6.91

ANSI/ASME STANDARD DOUBLE PITCH SLB SERIES



1. Features assembled rollers, **oil impregnated sintered bushings**, and **phosphate coated** roller link plates with nickel-plated pins.
2. SLB series chains are designed with the same **tensile strength** as ANSI/ASME standard chain and provide **greater resistance** to corrosion and wear.
3. Ideal for applications where it is difficult to access or maintain chain and a greater tensile strength is required.
4. SLB series chain is the **optimum choice** for conveyance applications.

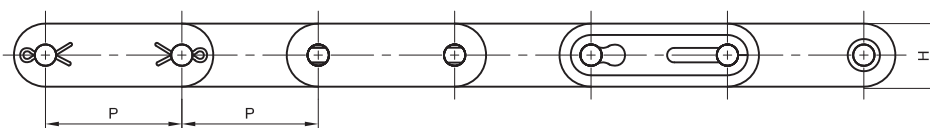
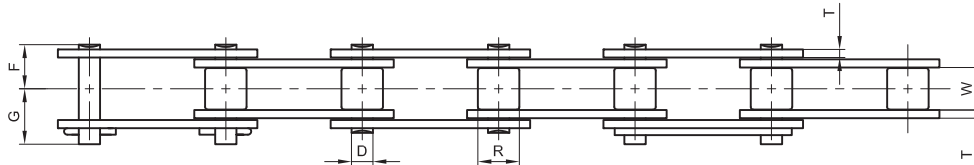

Dimensions: inch

Chain No.	Pitch	Roller		Plate		Pin Dia.	Overall Width		Avg. Ult. Tensile Strength (Lbs.)	Avg. Weight Per Foot (Lbs.)
		Width	Dia.	Height	Thickness		F	G		
	P	W	R	H	T	D	F	G		
C2040 SLB	1.000	0.312	0.312	0.463	0.060	0.157	0.406	0.324	4,180	0.39
C2050 SLB	1.250	0.375	0.400	0.594	0.080	0.200	0.488	0.400	7,810	0.58
C2060H SLB	1.500	0.500	0.469	0.712	0.125	0.235	0.665	0.567	12,540	1.04

ANSI/ASME STANDARD SLH SERIES



1. Features assembled rollers, **oil impregnated sintered bushings**, and **phosphate coated** roller link plates with nickel-plated pins.
2. SLH series chain is designed with the same features as SLB with the addition of thicker roller link plates providing the same maximum working loads and ANSI standard roller chain.
2. Ideal for applications where it is difficult to access or maintain chain and a greater working load is required.
4. SLB series chain is the optimal choice for **drive applications** at low to moderate speeds.

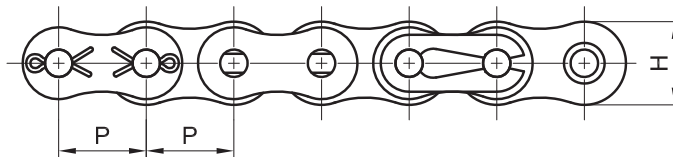
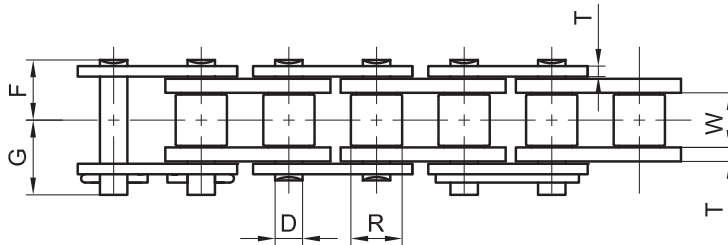

Dimensions: inch

Chain No.	Pitch	Roller		Plate			Pin Dia.	Overall Width		Avg. Ult. Tensile Strength (Lbs.)	Max. Working Load (Lbs.)	Avg. Weight Per Foot (Lbs.)
		Width	Dia.	Height	Thickness	Thickness		F	G			
	P	W	R	H	T1	T2	D	F	G			
40 SLH	0.500	0.312	0.312	0.475	0.060	0.080	0.157	0.665	0.567	4,180	816	0.50
50 SLH	0.625	0.375	0.400	0.594	0.080	0.094	0.200	0.411	0.344	6,820	1,400	0.79
60 SLH	0.750	0.500	0.469	0.712	0.094	0.125	0.235	0.490	0.423	9,240	2,094	1.22
80 SLH	1.000	0.625	0.625	0.950	0.125	0.156	0.313	0.616	0.541	17,600	3,307	1.98



ATTACHMENT CHAIN

Our PEER Chain attachment chain inventory spans a wide variety of sizes and configurations, available for a quick turn-a-round. We carry common, standard attachments for single and double pitch chain and also provide wide -contour attachments for both single and double pitch chain. Attachment chains are available in both carbon and stainless steel. Our expansive attachment inventory allows you to choose the attachment chains most suitable to your operation. PEER Chain also provides a multitude of special attachments to meet your needs. If you don't find what you are looking for, please contact us with your specifications.



Match Game

Test Your Knowledge!

Sure, you can “cheat” by looking at page, but what’s the fun in that? Create your own roller link from plate to plate!

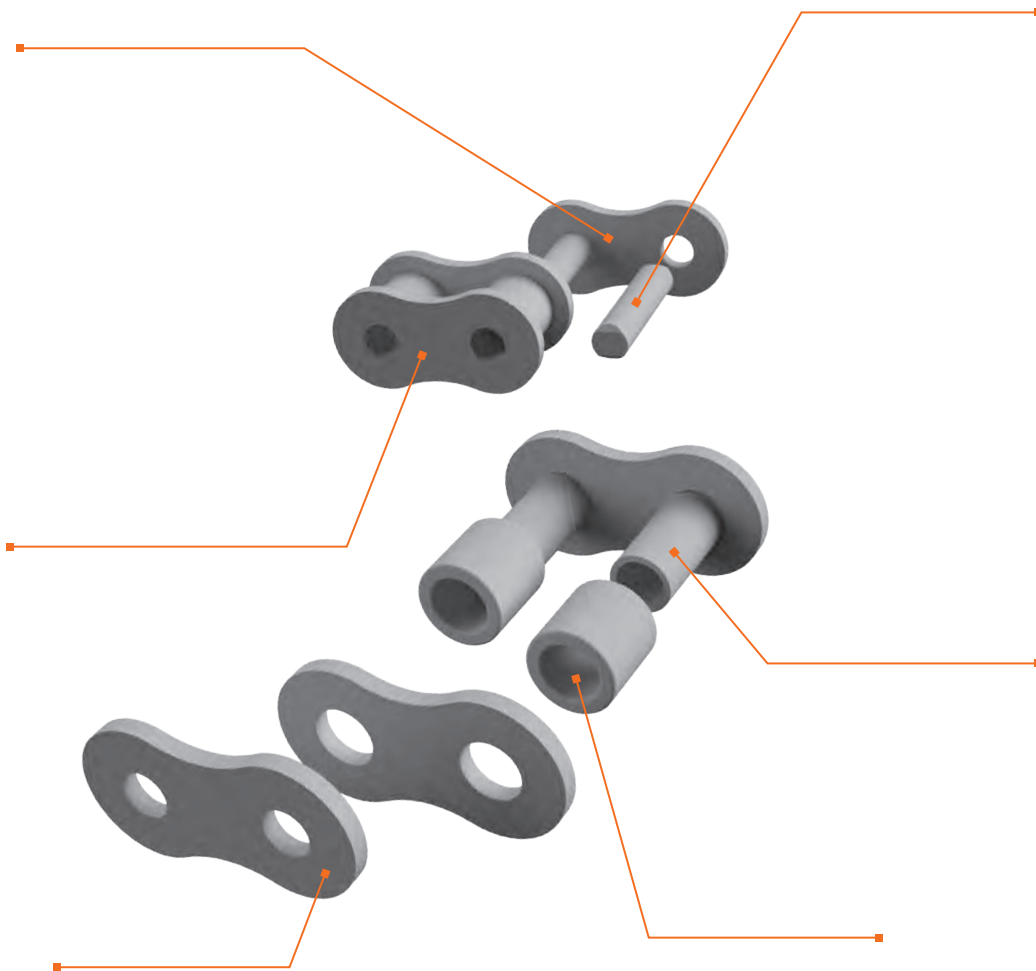

**At the beginning of each Escape Room, you will find a puzzle. Solve each puzzle to find the cryptic message in each Escape Room. Once you have completed the puzzles, visit our website (peerchain.com) and search for the discrete door and enter! Once you complete the form, what follows is all about our relationship with you!*

ANSI/ASME STANDARD ATTACHMENTS A-1 K-1

A-1 Attachment

Bent lug, one side with one hole in each tab

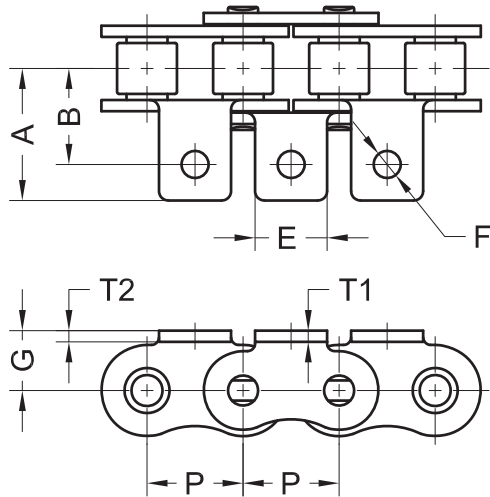

K-1 Attachment

Bent lug, both sides with one hole in each tab

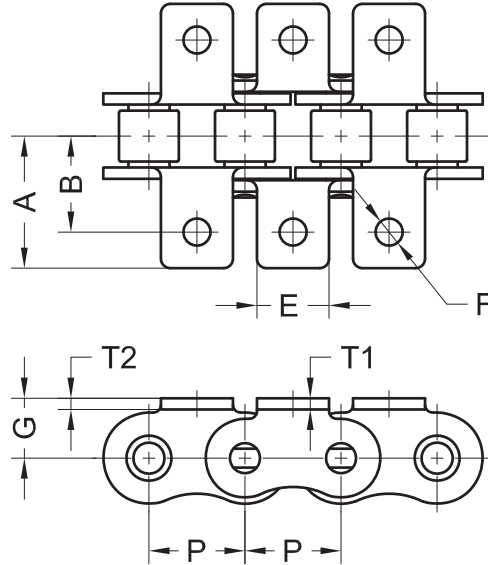

Dimensions: inch

Chain No.	Pitch	Attachment dimensions					
	P	A	B	E	F	G	T
35	0.375	0.516	0.375	0.313	0.102	0.250	0.050
35-2	0.375	0.516	0.375	0.313	0.102	0.250	0.050
40	0.500	0.687	0.500	0.375	0.141	0.312	0.060
40-2	0.500	0.687	0.500	0.375	0.141	0.312	0.060
41	0.500	0.641	0.469	0.375	0.141	0.281	0.050
50	0.625	0.972	0.625	0.562	0.203	0.406	0.080
50-2	0.625	0.972	0.625	0.562	0.203	0.406	0.080
60	0.750	1.103	0.750	0.625	0.203	0.469	0.094
60-2	0.750	1.103	0.750	0.625	0.203	0.469	0.094
80	1.000	1.378	1.000	0.750	0.266	0.625	0.125
80-2	1.000	1.378	1.000	0.750	0.266	0.625	0.125
100	1.250	1.693	1.250	1.000	0.328	0.781	0.156
100-2	1.250	1.693	1.250	1.000	0.328	0.781	0.156
120	1.500	2.091	1.500	1.125	0.392	0.906	0.187
120-2	1.500	2.091	1.500	1.125	0.392	0.906	0.187
140	1.750	2.498	1.750	1.375	0.450	1.125	0.219
140-2	1.750	2.498	1.750	1.375	0.450	1.125	0.219
160	2.000	2.672	2.000	1.500	0.518	1.250	0.250
160-2	2.000	2.672	2.000	1.500	0.518	1.250	0.250

ANSI/ASME STANDARD

ATTACHMENTS AA-1 KK-1

AA-1

Two bends, one side with one hole in each tab

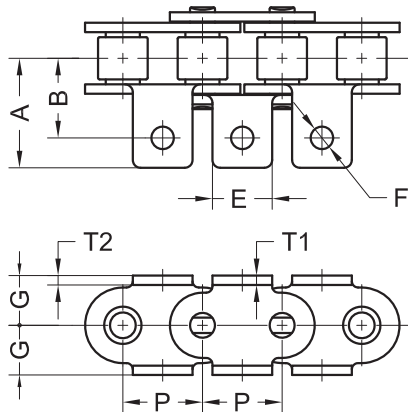

KK-1

Two bends, two sides with one hole in each tab

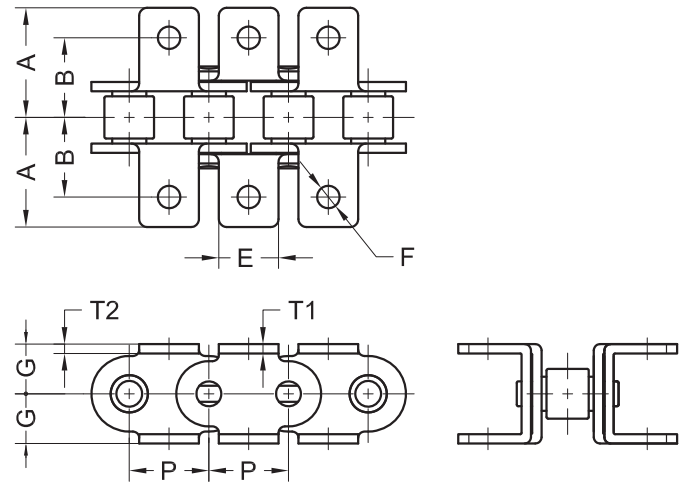

Dimensions: inch

Chain No.	Pitch	Attachment dimensions					
	P	A	B	E	F	G	T
35	0.375	0.516	0.375	0.313	0.102	0.250	0.050
35-2	0.375	0.516	0.375	0.313	0.102	0.250	0.050
40	0.500	0.687	0.500	0.375	0.141	0.312	0.060
40-2	0.500	0.687	0.500	0.375	0.141	0.312	0.060
41	0.500	0.641	0.469	0.375	0.141	0.281	0.050
50	0.625	0.972	0.625	0.562	0.203	0.406	0.080
50-2	0.625	0.972	0.625	0.562	0.203	0.406	0.080
60	0.750	1.103	0.750	0.625	0.203	0.469	0.094
60-2	0.750	1.103	0.750	0.625	0.203	0.469	0.094
80	1.000	1.378	1.000	0.750	0.266	0.625	0.125
80-2	1.000	1.378	1.000	0.750	0.266	0.625	0.125
100	1.250	1.693	1.250	1.000	0.328	0.781	0.156
100-2	1.250	1.693	1.250	1.000	0.328	0.781	0.156
120	1.500	2.091	1.500	1.125	0.392	0.906	0.187
120-2	1.500	2.091	1.500	1.125	0.392	0.906	0.187
140	1.750	2.498	1.750	1.375	0.450	1.125	0.219
140-2	1.750	2.498	1.750	1.375	0.450	1.125	0.219
160	2.000	2.672	2.000	1.500	0.518	1.250	0.250
160-2	2.000	2.672	2.000	1.500	0.518	1.250	0.250

ANSI/ASME STANDARD ATTACHMENTS SA-1 SK-1

SA-1 Straight one side with one hole in each tab
SK-1 Straight two sides with one hole in each tab

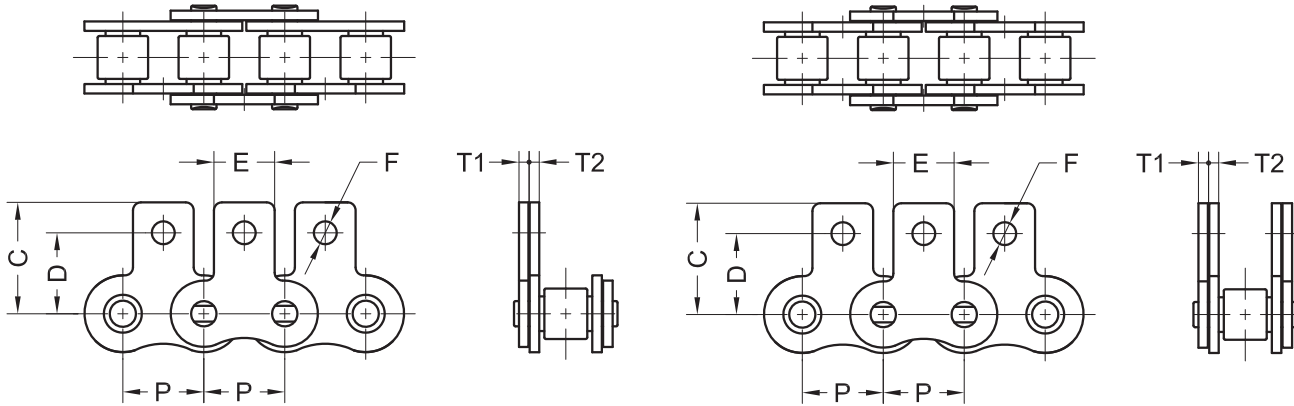

Dimensions: inch

Chain No.	Pitch	Attachment dimensions				
	P	C	D	E	F	T
35	0.375	0.528	0.375	0.313	0.102	0.050
35-2	0.375	0.528	0.375	0.313	0.102	0.050
40	0.500	0.691	0.500	0.375	0.141	0.060
40-2	0.500	0.691	0.500	0.375	0.141	0.060
41	0.500	0.648	0.500	0.375	0.141	0.050
50	0.625	0.969	0.625	0.562	0.203	0.080
50-2	0.625	0.969	0.625	0.562	0.203	0.080
60	0.750	1.037	0.719	0.625	0.203	0.094
60-2	0.750	1.037	0.719	0.625	0.203	0.094
80	1.000	1.341	0.969	0.750	0.266	0.125
80-2	1.000	1.341	0.969	0.750	0.266	0.125
100	1.250	1.657	1.250	1.000	0.328	0.156
100-2	1.250	1.657	1.250	1.000	0.328	0.156
120	1.500	2.022	1.438	1.125	0.392	0.187
120-2	1.500	2.022	1.438	1.125	0.392	0.187
140	1.750	2.500	1.752	1.375	0.450	0.219
140-2	1.750	2.500	1.752	1.375	0.450	0.219
160	2.000	2.605	2.000	1.500	0.518	0.250
160-2	2.000	2.605	2.000	1.500	0.518	0.250

ANSI/ASME STANDARD

ATTACHMENTS SAA-1 SKK-1

SAA-1

Two straight tabs one side
with one hole in each tab

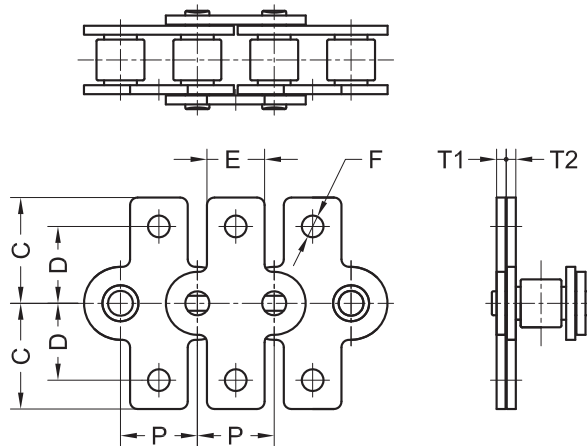

SKK-1

Two Straight tabs two sides
with one hole in each tab

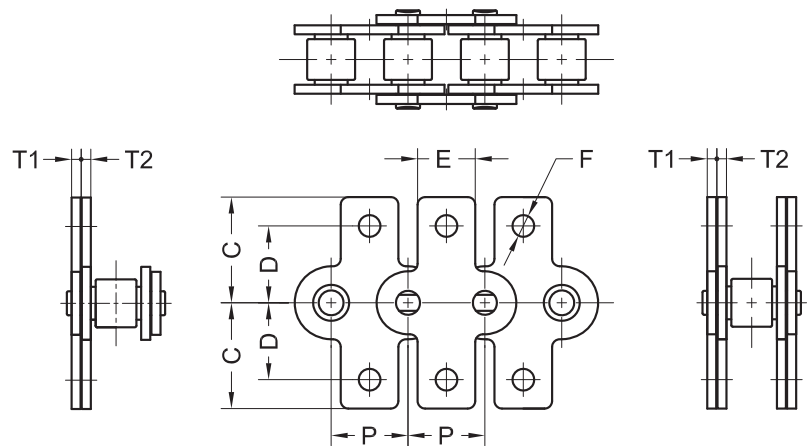

Dimensions: inch

Chain No.	Pitch P	Attachment dimensions					T
		C	D	E	F		
35	0.375	0.528	0.375	0.313	0.102	0.050	
35-2	0.375	0.528	0.375	0.313	0.102	0.050	
40	0.500	0.691	0.500	0.375	0.141	0.060	
40-2	0.500	0.691	0.500	0.375	0.141	0.060	
41	0.500	0.648	0.500	0.375	0.141	0.050	
50	0.625	0.969	0.625	0.562	0.203	0.080	
50-2	0.625	0.969	0.625	0.562	0.203	0.080	
60	0.750	1.037	0.719	0.625	0.203	0.094	
60-2	0.750	1.037	0.719	0.625	0.203	0.094	
80	1.000	1.341	0.969	0.750	0.266	0.125	
80-2	1.000	1.341	0.969	0.750	0.266	0.125	
100	1.250	1.657	1.250	1.000	0.328	0.156	
100-2	1.250	1.657	1.250	1.000	0.328	0.156	
120	1.500	2.022	1.438	1.125	0.392	0.187	
120-2	1.500	2.022	1.438	1.125	0.392	0.187	
140	1.750	2.500	1.752	1.375	0.450	0.219	
140-2	1.750	2.500	1.752	1.375	0.450	0.219	
160	2.000	2.605	2.000	1.500	0.518	0.250	
160-2	2.000	2.605	2.000	1.500	0.518	0.250	

ANSI/ASME STANDARD ATTACHMENTS WA-1 WK-1

WA-1

Wide contour bent one side with one hole in each tab

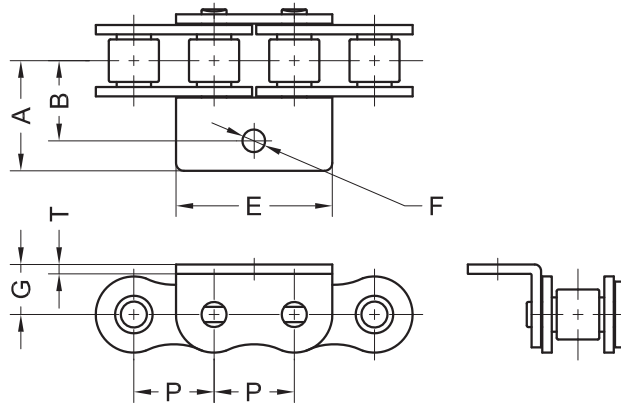

WK-1

Wide contour bent two sides with one hole in each tab

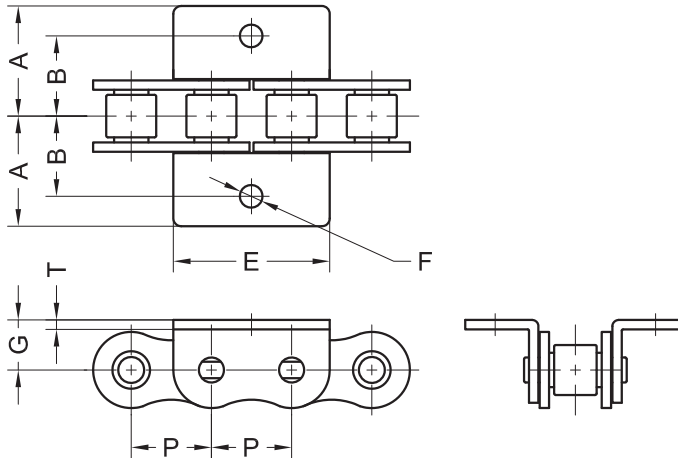

Dimensions: inch

Chain No.	Pitch	Attachment dimensions					
	P	A	B	E	F	G	T
35	0.375	0.566	0.375	0.722	0.109	0.250	0.050
40	0.500	0.687	0.500	0.909	0.141	0.312	0.060
41	0.500	0.776	0.588	0.823	0.187	0.305	0.050
50	0.625	0.972	0.625	1.131	0.203	0.406	0.080
60	0.750	1.063	0.750	1.427	0.203	0.469	0.094
80	1.000	1.387	1.000	1.915	0.266	0.625	0.125
100	1.250	1.776	1.250	2.437	0.328	0.781	0.156
120	1.500	2.091	1.500	2.799	0.392	0.906	0.187
140	1.750	2.498	1.750	3.181	0.450	1.125	0.219
160	2.000	2.815	2.000	3.890	0.518	1.250	0.250

ANSI/ASME STANDARD

ATTACHMENTS WA-2 WK-2

WA-2

Wide contour bent one side with two holes in each tab

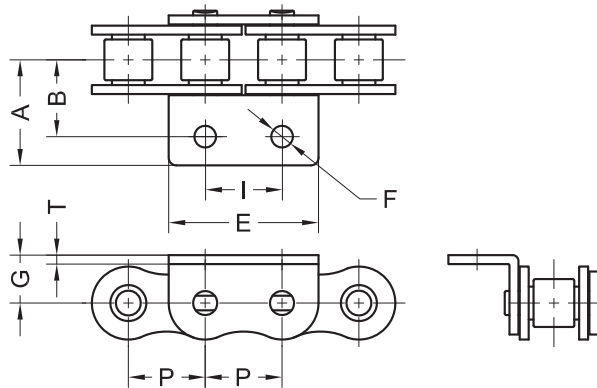

WK-2

Wide contour bent two sides with two holes in each tab

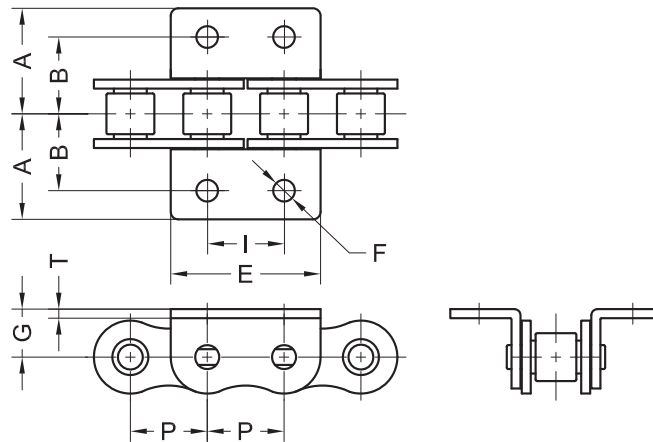

Dimensions: inch

Chain No.	Pitch P	Attachment dimensions						
		A	B	E	F	G	I	T
35	0.375	0.566	0.375	0.722	0.109	0.250	0.375	0.050
40	0.500	0.687	0.500	0.909	0.141	0.312	0.500	0.060
41	0.500	0.776	0.588	0.823	0.187	0.305	0.500	0.050
50	0.625	0.972	0.625	1.131	0.203	0.406	0.625	0.080
60	0.750	1.063	0.750	1.427	0.203	0.469	0.750	0.094
80	1.000	1.387	1.000	1.915	0.266	0.625	1.000	0.125
100	1.250	1.776	1.250	2.437	0.328	0.781	1.250	0.156
120	1.500	2.091	1.500	2.799	0.392	0.906	1.500	0.187
140	1.750	2.498	1.750	3.181	0.450	1.125	1.750	0.219
160	2.000	2.815	2.000	3.890	0.518	1.250	2.000	0.250

ANSI/ASME STANDARD ATTACHMENTS WSA-1 WSK-1

WSA-1

Wide contour straight one side with one hole in each tab

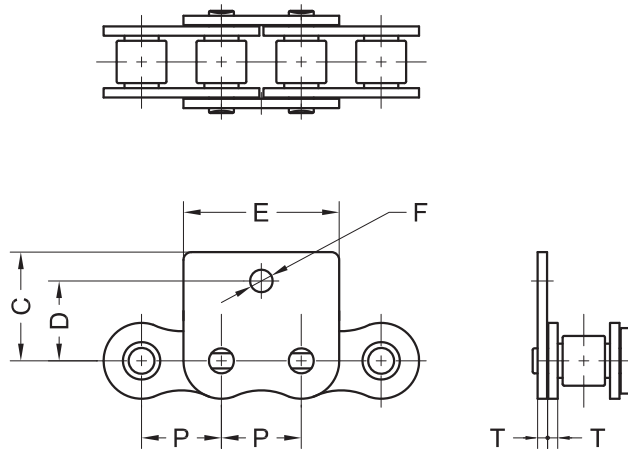

WSK-1

Wide contour straight two sides with one hole in each tab

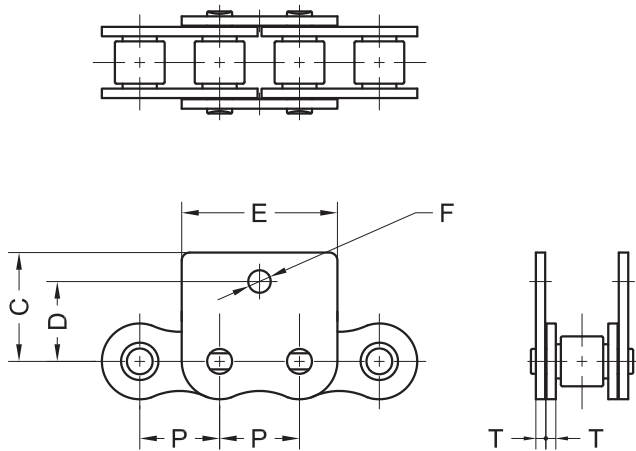

Dimensions: inch

Chain No.	Pitch	Attachment dimensions				
	P	C	D	E	F	T
35	0.375	0.581	0.375	0.722	0.109	0.050
40	0.500	0.685	0.500	0.909	0.141	0.060
50	0.625	0.972	0.625	1.131	0.203	0.080
60	0.750	1.024	0.719	1.427	0.203	0.094
80	1.000	1.355	0.969	1.915	0.266	0.125
100	1.250	1.732	1.250	2.437	0.328	0.156
120	1.500	2.022	1.438	2.925	0.392	0.187
140	1.750	2.500	1.750	3.413	0.450	0.219

ANSI/ASME STANDARD

ATTACHMENTS WSA-2 WSK-2

WSA-2

Wide contour straight one side with two holes in each tab

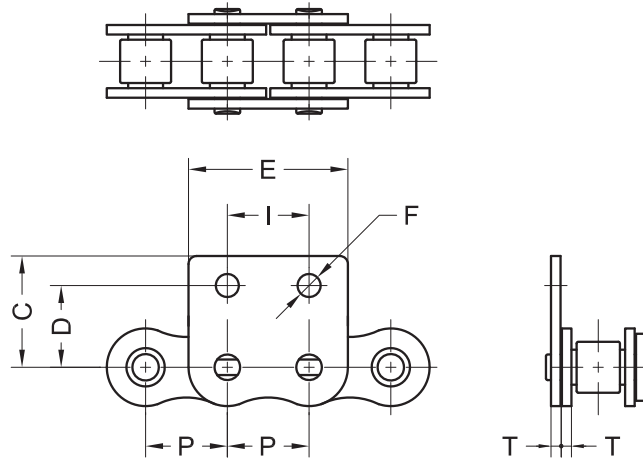

WSK-2

Wide contour straight two sides with two holes in each tab

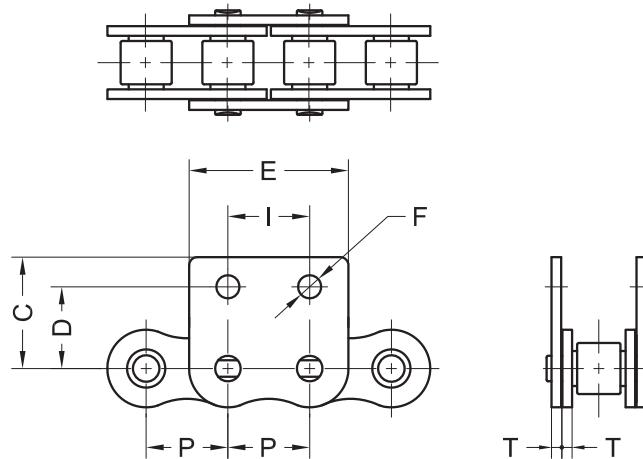

Dimensions: inch

Chain No.	Pitch	Attachment dimensions					
	P	C	D	E	F	I	T
35	0.375	0.581	0.375	0.722	0.109	0.375	0.050
40	0.500	0.685	0.500	0.909	0.141	0.500	0.060
50	0.625	0.972	0.625	1.131	0.203	0.625	0.080
60	0.750	1.024	0.719	1.427	0.203	0.750	0.094
80	1.000	1.355	0.969	1.915	0.266	1.000	0.125
100	1.250	1.732	1.250	2.437	0.328	1.250	0.156
120	1.500	2.022	1.438	2.925	0.392	1.500	0.187
140	1.750	2.500	1.750	3.413	0.450	1.750	0.219

ANSI/ASME STANDARD ATTACHMENTS D-1 DD-1

D-1

One pin extended one side

DD-1

One pin extended two sides

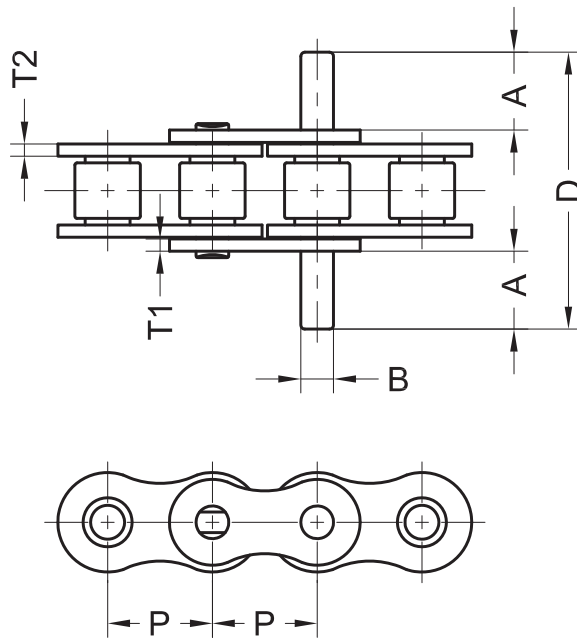
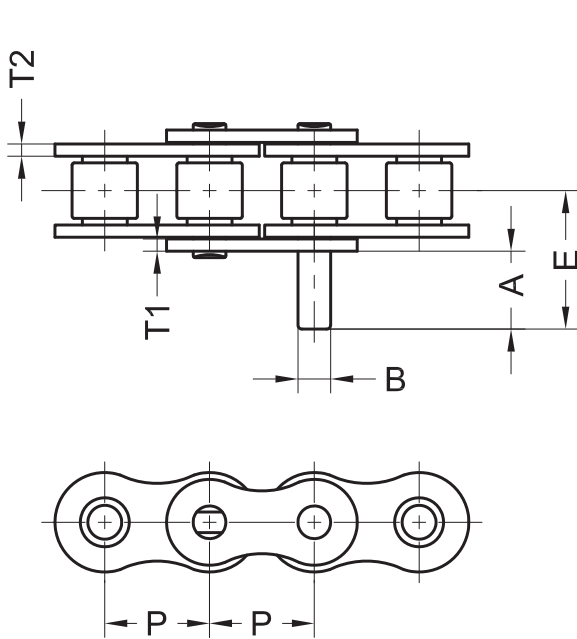

Dimensions: inch

Chain No.	Pitch	Attachment dimensions				
	P	A	B	D	E	T
35	0.375	0.375	0.141	1.150	0.575	0.050
40	0.500	0.375	0.156	1.322	0.661	0.060
41	0.500	0.375	0.141	1.216	0.608	0.050
50	0.625	0.469	0.200	1.654	0.827	0.080
60	0.750	0.562	0.234	2.036	1.018	0.094
80	1.000	0.750	0.312	2.670	1.335	0.125
100	1.250	0.938	0.375	3.296	1.648	0.156
120	1.500	1.125	0.437	4.048	2.024	0.187
140	1.750	1.312	0.500	4.528	2.264	0.219
160	2.000	1.500	0.562	5.308	2.654	0.250
200	2.500	1.875	0.781	6.805	3.402	0.312

ANSI/ASME STANDARD

ATTACHMENTS D-3 DD-3

D-3

Two pins extended one side

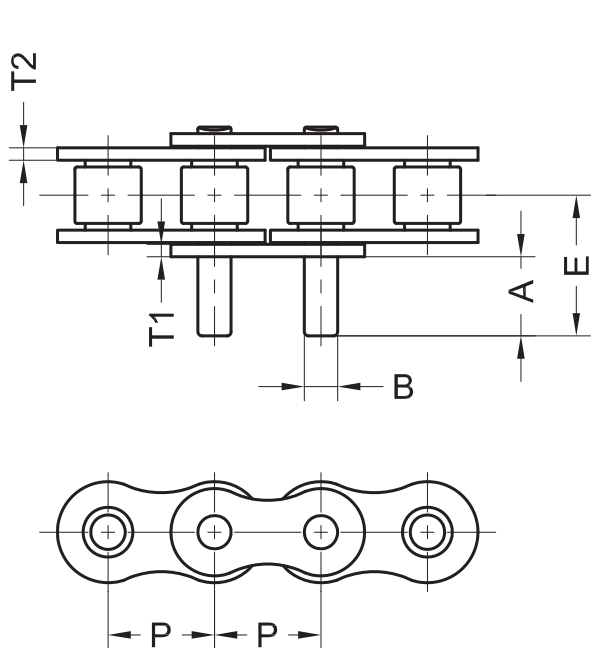

DD-3

Two pins extended two sides

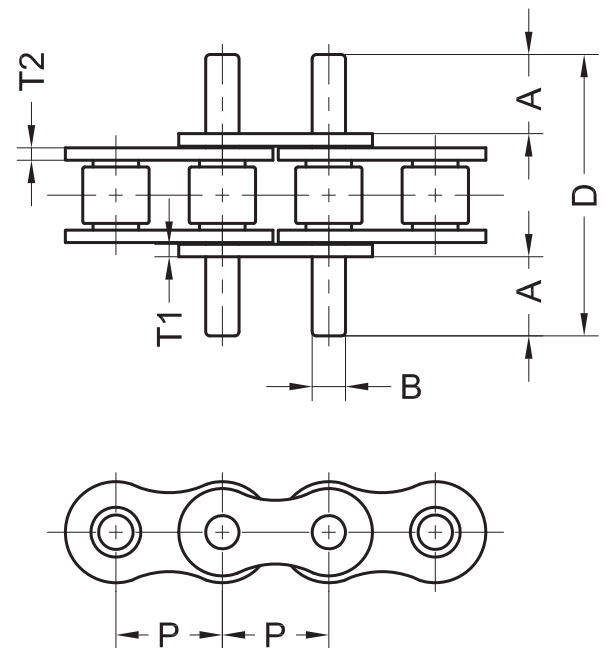

Dimensions: inch

Chain No.	Pitch	Attachment dimensions				
	P	A	B	D	E	T
35	0.375	0.375	0.141	1.150	0.575	0.050
40	0.500	0.375	0.156	1.322	0.661	0.060
41	0.500	0.375	0.141	1.216	0.608	0.050
50	0.625	0.469	0.200	1.654	0.827	0.080
60	0.750	0.562	0.234	2.036	1.018	0.094
80	1.000	0.750	0.312	2.670	1.335	0.125
100	1.250	0.938	0.375	3.296	1.648	0.156
120	1.500	1.125	0.437	4.048	2.024	0.187
140	1.750	1.312	0.500	4.528	2.264	0.219
160	2.000	1.500	0.562	5.308	2.654	0.250
200	2.250	1.875	0.781	6.805	3.402	0.312

ANSI/ASME STANDARD DOUBLE PITCH ATTACHMENTS A-1 K-1

ANSI/ASME
STANDARD

ANSI/ASME
HEAVY

DOUBLE
PITCH

ISO
BRITISH

CORROSION
RESISTANT

SELF
LUBE

ATTACHMENT
CHAIN

SPECIALTY
CHAIN

LEAF
CHAIN

A-1

Bent one side with one hole in each tab

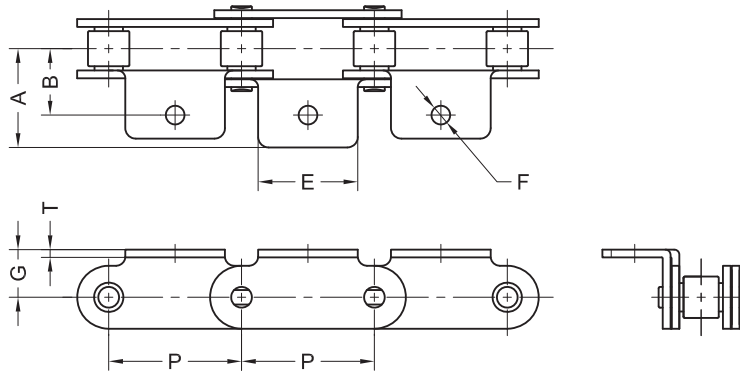

K-1

Bent two sides with one hole in each tab

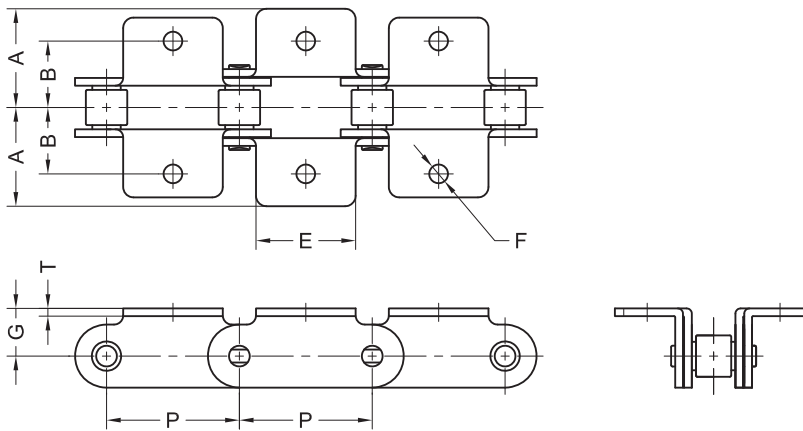

Dimensions: inch

Chain No.	Pitch	Attachment dimensions					
		P	A	B	E	F	G
C2040	1.000	0.742	0.500	0.750	0.141	0.359	0.060
C2050	1.250	0.945	0.625	1.000	0.203	0.438	0.080
C2060H	1.500	1.203	0.844	1.125	0.203	0.578	0.125
C2080H	2.000	1.575	1.094	1.500	0.266	0.750	0.156
C2100H	2.500	1.965	1.312	1.875	0.328	0.922	0.187
C2120H	3.000	2.390	1.562	2.250	0.391	1.094	0.219
C2160H	4.000	3.157	2.062	2.965	0.518	1.438	0.281

ANSI/ASME STANDARD DOUBLE PITCH ATTACHMENTS A-2 K-2

A-2

Bent one side with two holes in each tab

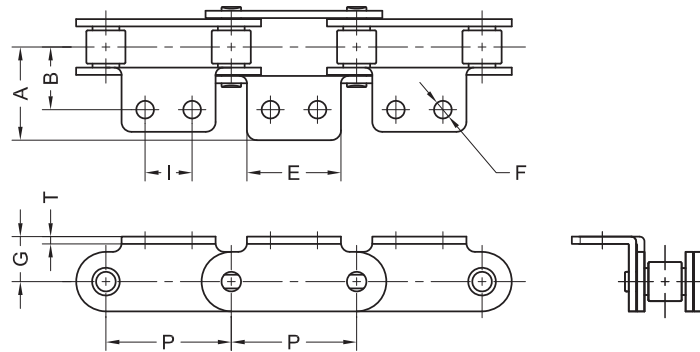

K-2

Bent two sides with two holes in each tab

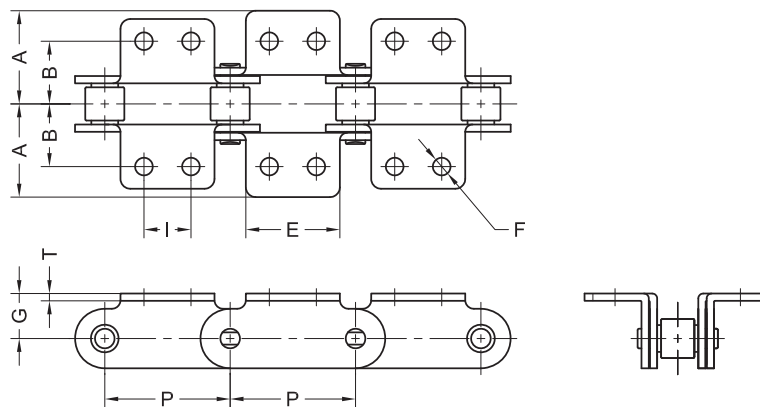

Dimensions: inch

Chain No.	Pitch	Attachment dimensions						
	P	A	B	E	F	G	I	T
C2040	1.000	0.742	0.500	0.750	0.141	0.359	0.375	0.060
C2050	1.250	0.945	0.625	1.000	0.203	0.438	0.469	0.080
C2060H	1.500	1.203	0.844	1.125	0.203	0.578	0.562	0.125
C2080H	2.000	1.575	1.094	1.500	0.266	0.750	0.750	0.156
C2100H	2.500	1.965	1.312	1.875	0.328	0.922	0.937	0.187
C2120H	3.000	2.390	1.562	2.250	0.391	1.094	1.125	0.219
C2160H	4.000	3.157	2.062	2.965	0.518	1.438	1.500	0.281

ANSI/ASME STANDARD DOUBLE PITCH ATTACHMENTS AA-1 KK-1

AA-1

Two bends one side with one hole in each tab

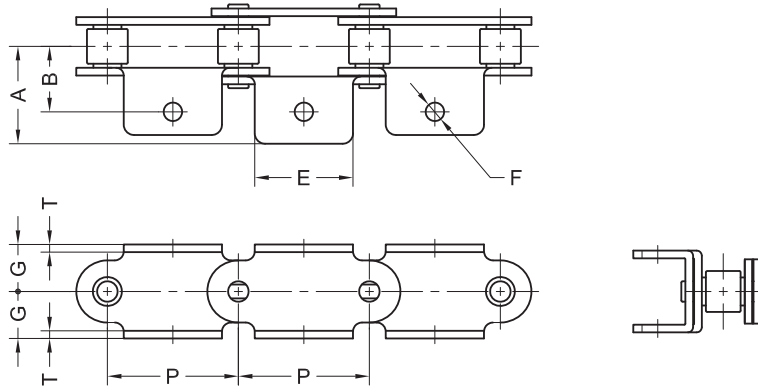

KK-1

Two bends two sides with one hole in each tab

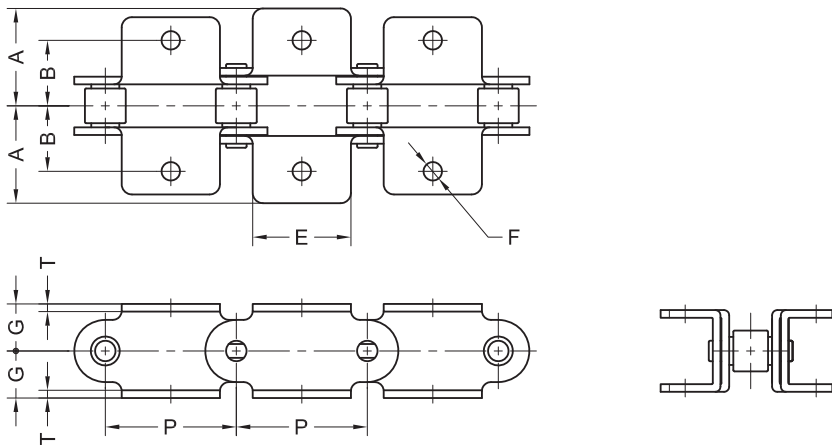

Dimensions: inch

Chain No.	Pitch	Attachment dimensions					
	P	A	B	E	F	G	T
C2040	1.000	0.742	0.500	0.750	0.141	0.359	0.060
C2050	1.250	0.945	0.625	1.000	0.203	0.438	0.080
C2060H	1.500	1.203	0.844	1.125	0.203	0.578	0.125
C2080H	2.000	1.575	1.094	1.500	0.266	0.750	0.156
C2100H	2.500	1.965	1.312	1.875	0.328	0.922	0.187
C2120H	3.000	2.390	1.562	2.250	0.391	1.094	0.219
C2160H	4.000	3.157	2.062	2.965	0.518	1.438	0.281

ANSI/ASME STANDARD DOUBLE PITCH ATTACHMENTS SA-1 SK-1

SA-1

Straight one side with one hole in each tab

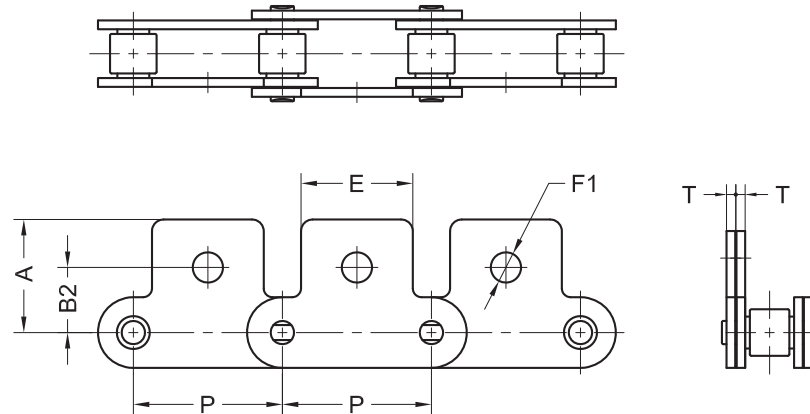

SK-1

Straight two sides with one hole in each tab

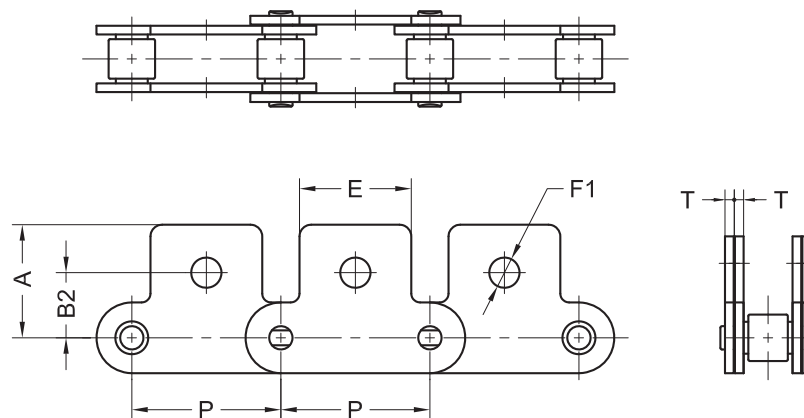

Dimensions: inch

Chain No.	Pitch	Attachment dimensions				
	P	A	B2	E	F	T
C2040	0.375	0.759	0.438	0.750	0.203	0.060
C2050	0.375	0.969	0.562	1.000	0.250	0.080
C2060H	0.500	1.172	0.688	1.125	0.328	0.125
C2080H	0.500	1.500	0.875	1.500	0.391	0.156
C2100H	0.500	1.984	1.125	1.875	0.516	0.187
C2120H	0.625	2.359	1.312	2.250	0.578	0.219
C2160H	0.625	3.025	1.750	2.965	0.766	0.281

ANSI/ASME STANDARD DOUBLE PITCH ATTACHMENTS SA-2 SK-2

SA-2

Straight one side with two holes in each tab

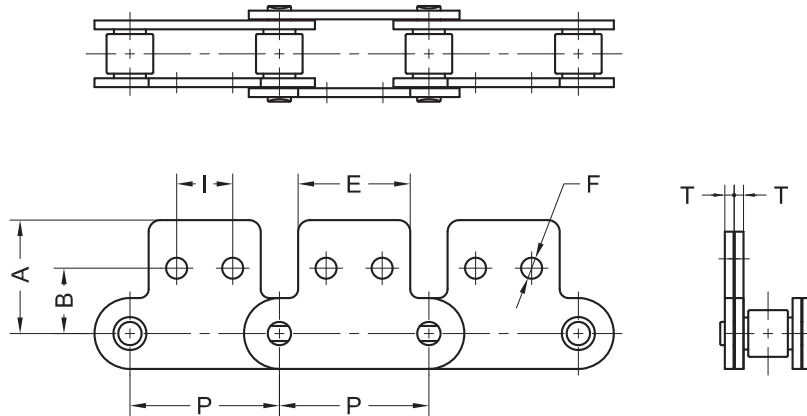

SK-2

Straight two sides with two holes in each tab

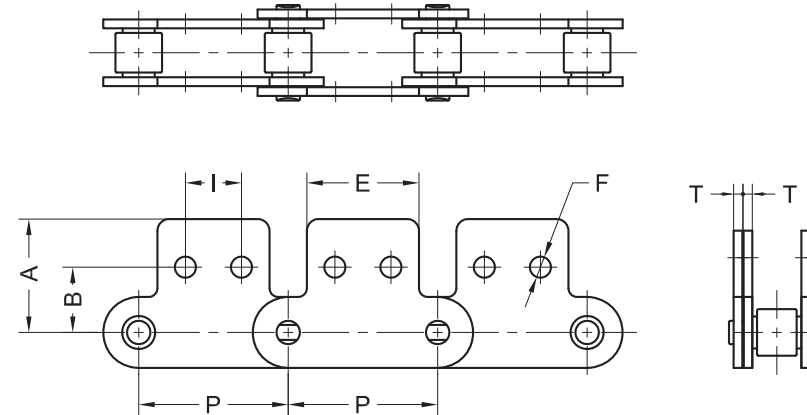

Dimensions: inch

Chain No.	Pitch	Attachment dimensions					
	P	A	B	E	F	I	T
C2040	0.375	0.759	0.531	0.750	0.141	0.375	0.060
C2050	0.375	0.969	0.625	1.000	0.203	0.469	0.080
C2060H	0.500	1.172	0.750	1.125	0.203	0.562	0.125
C2080H	0.500	1.500	1.000	1.500	0.266	0.750	0.156
C2100H	0.500	1.984	1.250	1.875	0.328	0.938	0.187
C2120H	0.625	2.359	1.469	2.250	0.390	1.125	0.219
C2160H	0.625	3.025	2.000	2.965	0.521	1.500	0.281

ANSI/ASME STANDARD

DOUBLE PITCH

ATTACHMENTS SAA-1 SKK-1

SAA-1

Two straight one side with one hole in each tab

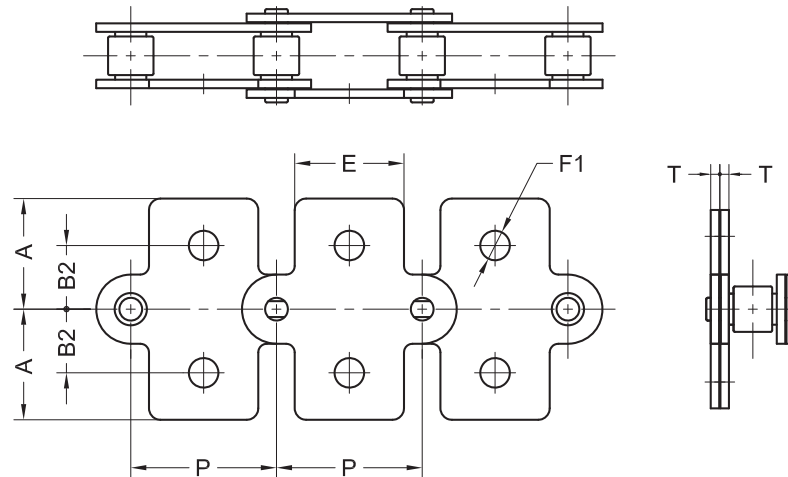

SKK-1

Two straight two sides with one hole in each tab

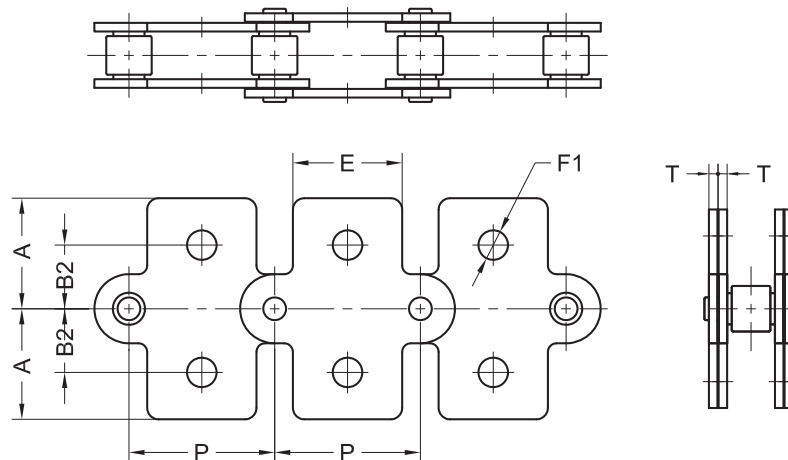

Dimensions: inch

Chain No.	Pitch	Attachment dimensions				
		P	A	B2	E	F
C2040	0.375	0.759	0.438	0.750	0.141	0.060
C2050	0.375	0.969	0.562	1.000	0.203	0.080
C2060H	0.500	1.172	0.688	1.125	0.203	0.125
C2080H	0.500	1.500	0.875	1.500	0.266	0.156
C2100H	0.500	1.984	1.125	1.875	0.328	0.187
C2120H	0.625	2.359	1.312	2.250	0.390	0.219
C2160H	0.625	3.025	1.750	2.965	0.521	0.281

ANSI/ASME STANDARD DOUBLE PITCH ATTACHMENTS D-1 DD-1

D-1

One pin extended one side

DD-1

One pin extended two sides

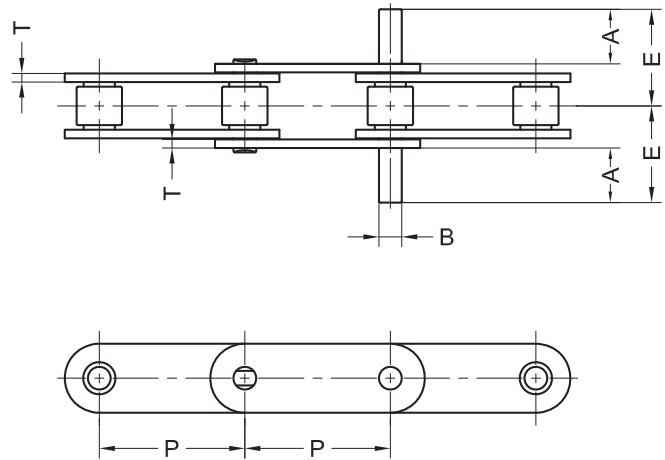
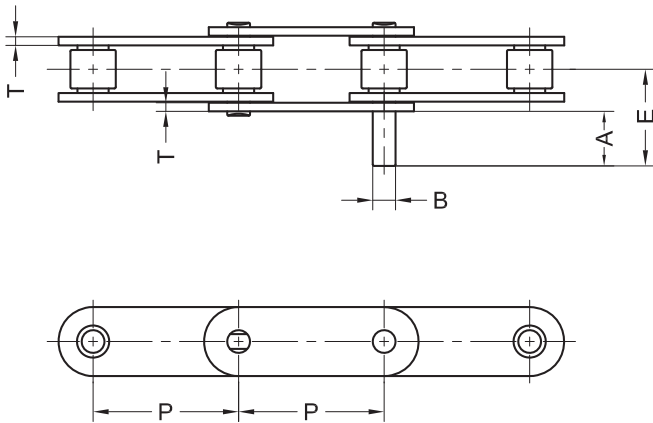

Dimensions: inch

Chain No.	Pitch	Attachment dimensions			
	P	A	B	T	E
C2040	1.000	0.375	0.157	0.060	0.661
C2050	1.250	0.469	0.200	0.080	0.827
C2060H	1.500	0.562	0.235	0.125	1.062
C2080H	2.000	0.750	0.313	0.156	1.375
C2100H	2.500	0.930	0.376	0.187	1.679
C2120H	3.000	1.125	0.437	0.219	2.063
C2160H	4.000	1.500	0.563	0.281	2.687

ANSI/ASME STANDARD

DOUBLE PITCH

ATTACHMENTS D-3 DD-3

D-3

Two pins extended one side

DD-3

Two pins extended two sides

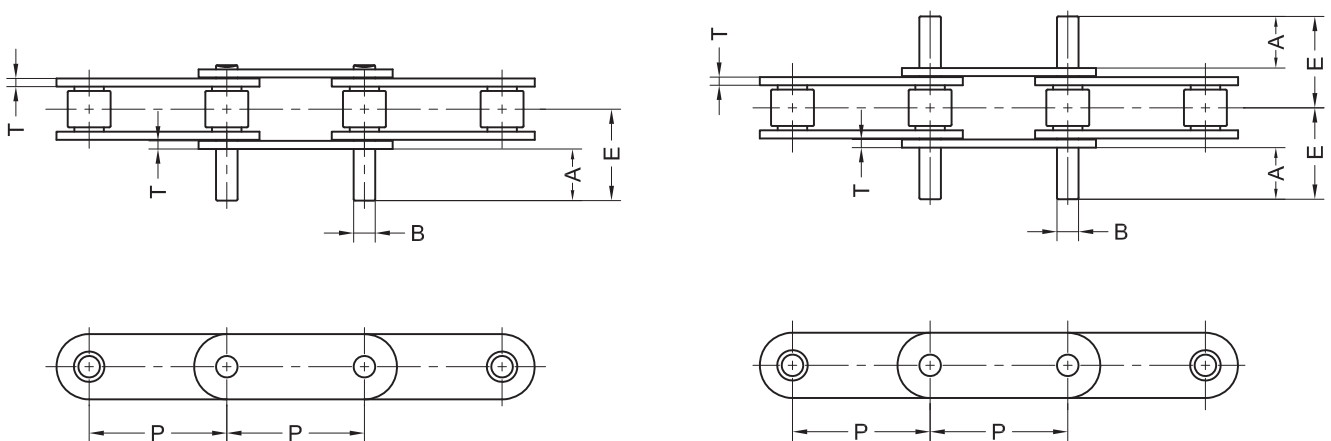

Dimensions: inch

Chain No.	Pitch	Attachment dimensions			
	P	A	B	T	E
C2040	1.000	0.375	0.157	0.060	0.661
C2050	1.250	0.469	0.200	0.080	0.827
C2060H	1.500	0.562	0.235	0.125	1.062
C2080H	2.000	0.750	0.313	0.156	1.375
C2100H	2.500	0.930	0.376	0.187	1.679
C2120H	3.000	1.125	0.437	0.219	2.063
C2160H	4.000	1.500	0.563	0.281	2.687

ANSI/ASME STANDARD DOUBLE PITCH ATTACHMENTS D-5

D-5

One pin extended on one side in center of the link

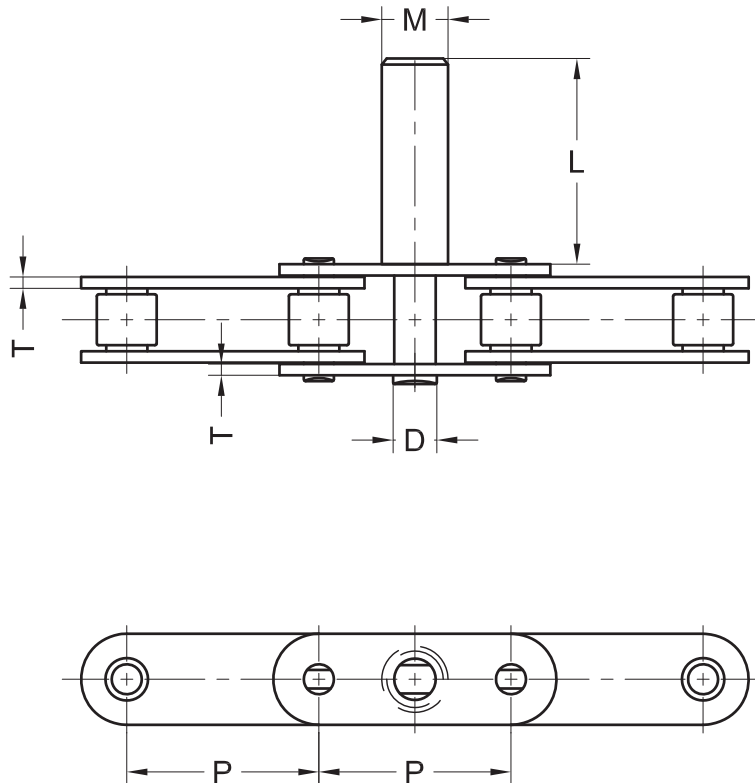

Dimensions: inch

Chain No.	Pitch	Attachment dimensions			
	P	L	M	D	T
C2040	1.000	0.750	0.250	0.157	0.060
C2050	1.250	0.773	0.282	0.200	0.080
C2060H 1/2"	1.500	1.625	0.500	0.313	0.125
C2060H 1/2" TD	1.500	1.625	0.500	0.235	0.125
C2060H 9/16"	1.500	1.625	0.563	0.313	0.125
C2080H 1/2"	2.000	1.625	0.500	0.313	0.156
C2080H 17/32"	2.000	1.250	0.523	0.313	0.156
C2100H	2.500	1.563	0.563	0.375	0.187

ANSI/ASME STANDARD DOUBLE PITCH ATTACHMENTS G-1

G-1

One thru hole on each plate in center of link

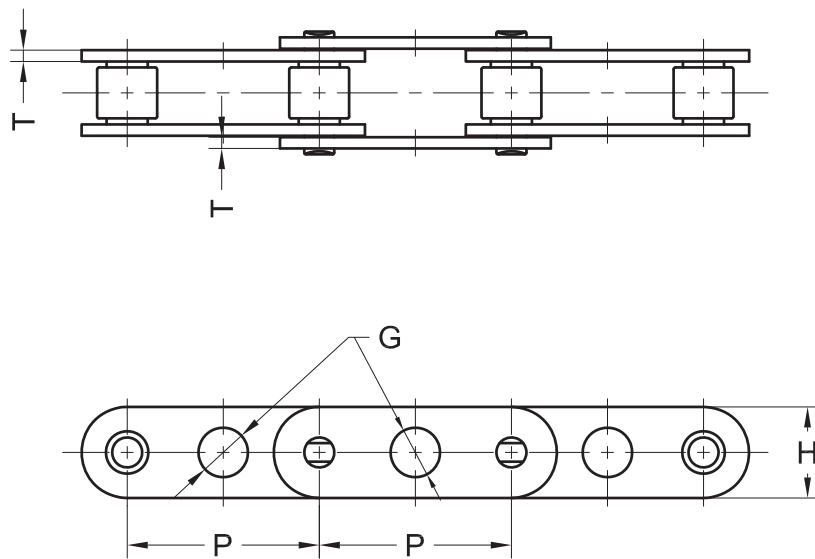

Dimensions: inch

Chain No.	Pitch	Attachment dimensions		
	P	H	G	T
C2040	1.000	0.463	0.156	0.060
C2040	1.000	0.463	0.250	0.060
C2040	1.000	0.463	0.313	0.060
C2050	1.250	0.594	0.219	0.080
C2060H	1.500	0.712	0.235	0.125
C2080H	2.000	0.950	0.313	0.156
C2100H	2.500	1.187	0.376	0.187

ISO BRITISH METRIC STANDARD ATTACHMENTS A-1 K-1

A-1

Bent one side with one hole in each tab

K-1

Bent two sides with one hole in each tab

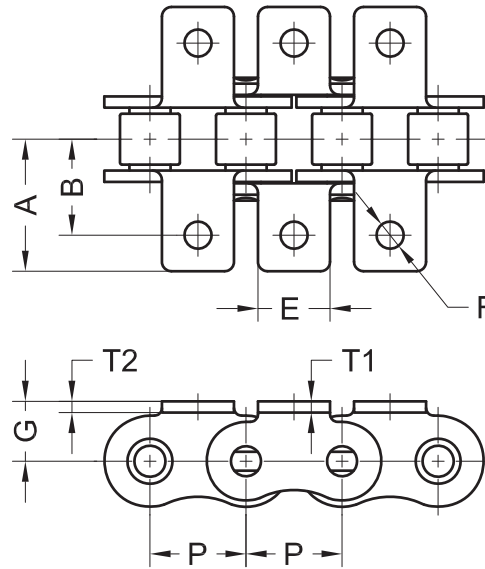
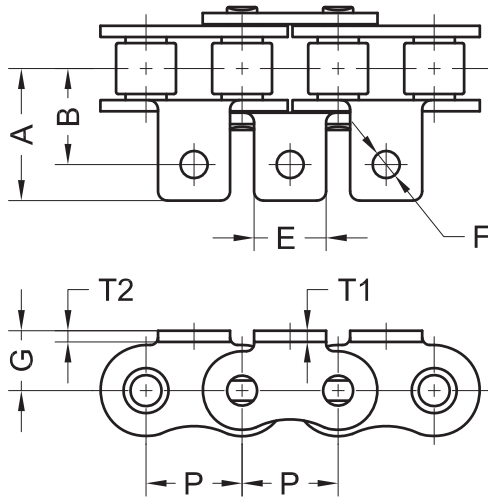

Dimensions: inch

Chain No.	Pitch P	Attachment dimensions						
		A	B	E	F	G	T1	T2
06B	0.375	0.531	0.375	0.315	0.102	0.256	0.039	0.050
08B	0.500	0.717	0.500	0.433	0.169	0.350	0.059	0.062
10B	0.325	0.878	0.625	0.562	0.209	0.406	0.067	0.067
12B	0.750	1.028	0.750	0.625	0.252	0.531	0.073	0.073
16B	1.000	1.429	1.000	0.750	0.252	0.626	0.125	0.157
20B	1.250	1.675	1.250	1.012	0.331	0.780	0.125	0.176
24B	1.500	2.134	1.500	1.181	0.413	1.051	0.189	0.236
28B	1.750	2.421	1.750	1.378	0.516	1.126	0.236	0.287

ISO BRITISH METRIC STANDARD

ATTACHMENTS SA-1 SK-1

SA-1

Straight one side with one hole in each tab

SK-1

Straight two sides with one hole in each tab

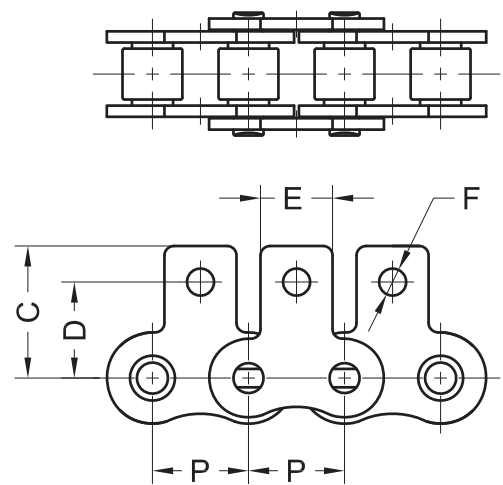
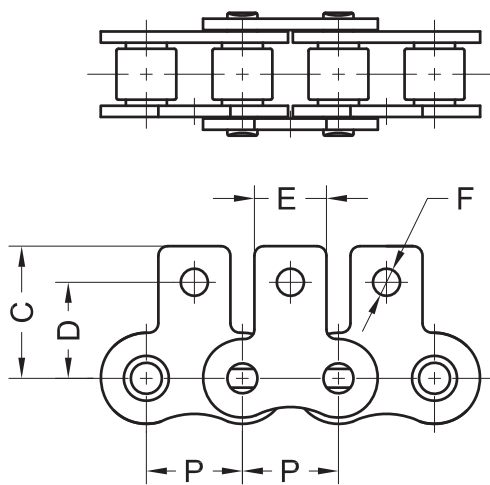

Dimensions: inch

Chain No.	Pitch	Attachment dimensions					
	P	C	D	E	F	T1	T2
06B	0.375	0.535	0.375	0.315	0.102	0.039	0.050
08B	0.500	0.742	0.526	0.433	0.169	0.059	0.062
10B	0.325	0.904	0.650	0.562	0.209	0.067	0.067
12B	0.750	1.122	0.844	0.625	0.252	0.073	0.073
16B	1.000	1.337	0.911	0.750	0.252	0.125	0.157
20B	1.250	1.657	1.201	1.012	0.331	0.125	0.176
24B	1.500	2.102	1.417	1.181	0.413	0.189	0.236
28B	1.750			1.378	0.516	0.236	0.287

ISO BRITISH METRIC STANDARD ATTACHMENTS WA-1 WK-1

ANSI/ASME
 STANDARD

ANSI/ASME
 HEAVY

DOUBLE
 PITCH

ISO
 BRITISH

CORROSION
 RESISTANT

SELF
 LUBE

ATTACHMENT
 CHAIN

SPECIALTY
 CHAIN

LEAF
 CHAIN

WA-1

Wide contour bent one side with one hole in each tab

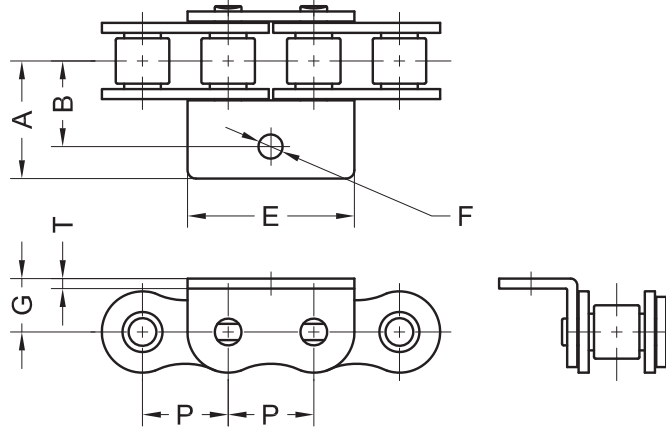

WK-1

Wide contour bent two sides with one hole in each tab

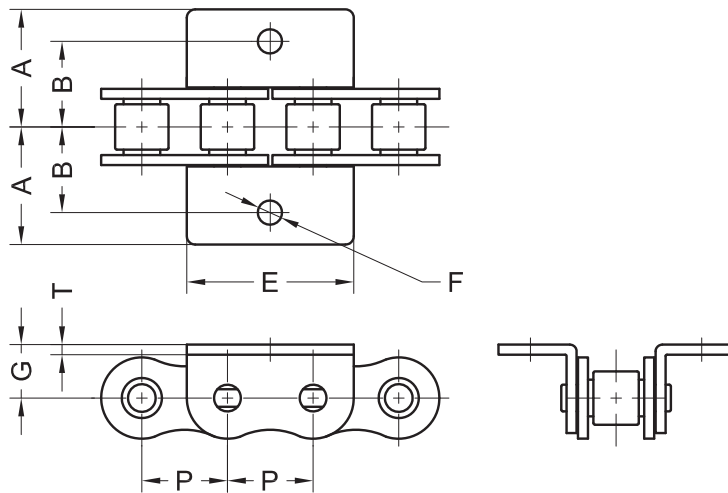

Dimensions: inch

Chain No.	Pitch P	Attachment dimensions						
		A	B	E	F	G	T1	T2
06B	0.375	0.531	0.375	0.701	0.102	0.256	0.039	0.050
08B	0.500	0.717	0.500	0.963	0.169	0.350	0.059	0.062
10B	0.625	0.878	0.625	1.204	0.209	0.406	0.067	0.067
12B	0.750	1.028	0.750	1.385	0.252	0.531	0.073	0.073
16B	1.000	1.429	1.000	1.815	0.252	0.626	0.125	0.157

ISO BRITISH METRIC STANDARD

ATTACHMENTS WA-2 WK-2

WA-2

Wide contour bent one side with two holes in each tab

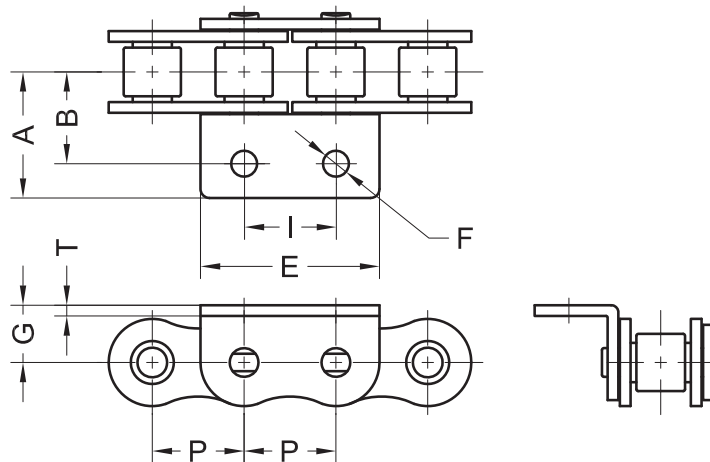

WK-2

Wide contour bent two sides with two holes in each tab

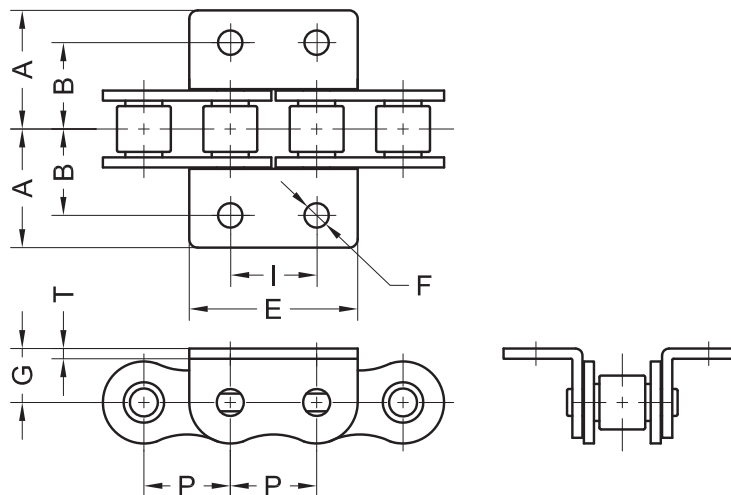

Dimensions: inch

Chain No.	Pitch	Attachment dimensions							
	P	A	B	E	F	G	I	T1	T2
06B	0.375	0.531	0.375	0.701	0.102	0.256	0.375	0.039	0.050
08B	0.500	0.717	0.500	0.963	0.169	0.350	0.500	0.059	0.062
10B	0.625	0.878	0.625	1.204	0.209	0.406	0.625	0.067	0.067
12B	0.750	1.028	0.750	1.385	0.252	0.531	0.750	0.073	0.073
16B	1.000	1.429	1.000	1.815	0.252	0.626	1.000	0.125	0.157

ISO BRITISH METRIC STANDARD

ATTACHMENTS WSA-1 WSK-1

WSA-1

Wide contour straight one side with one hole in each tab

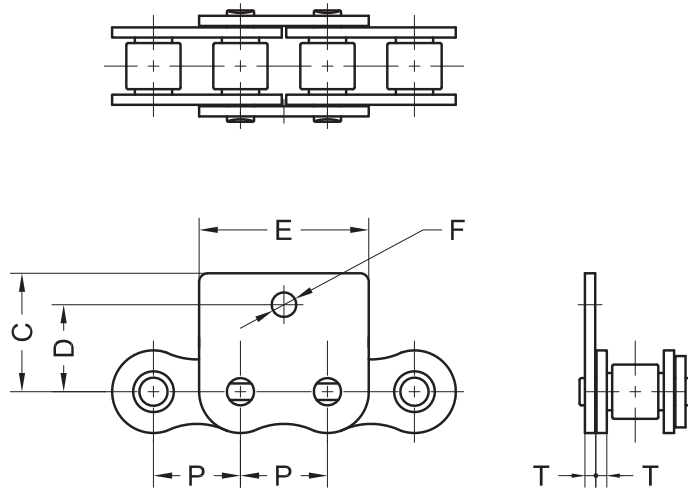

WSK-1

Wide contour straight two sides with one hole in each tab

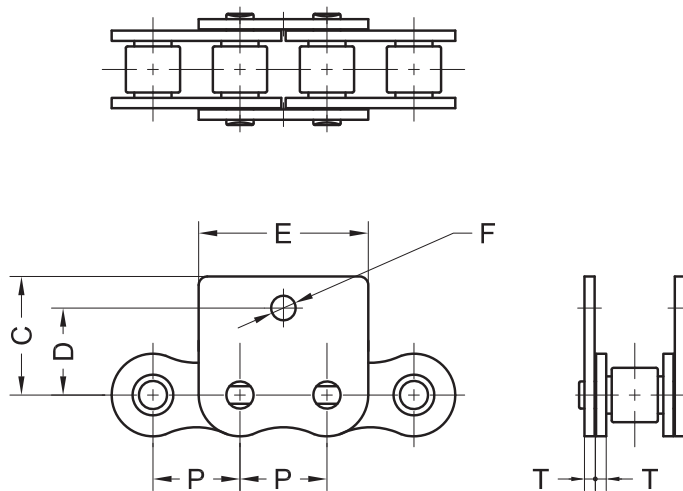

Dimensions: inch

Chain No.	Pitch	Attachment dimensions					
	P	C	D	E	F	T1	T2
06B	0.375	0.535	0.375	0.701	0.102	0.039	0.050
08B	0.500	0.742	0.526	0.963	0.169	0.059	0.062
10B	0.625	0.904	0.650	1.204	0.209	0.067	0.067
12B	0.750	1.122	0.844	1.385	0.252	0.073	0.073
16B	1.000	1.337	0.911	1.815	0.252	0.125	0.157

ISO BRITISH METRIC STANDARD

ATTACHMENTS WSA-2 WSK-2

WSA-2

Wide contour straight one side with two holes in each tab

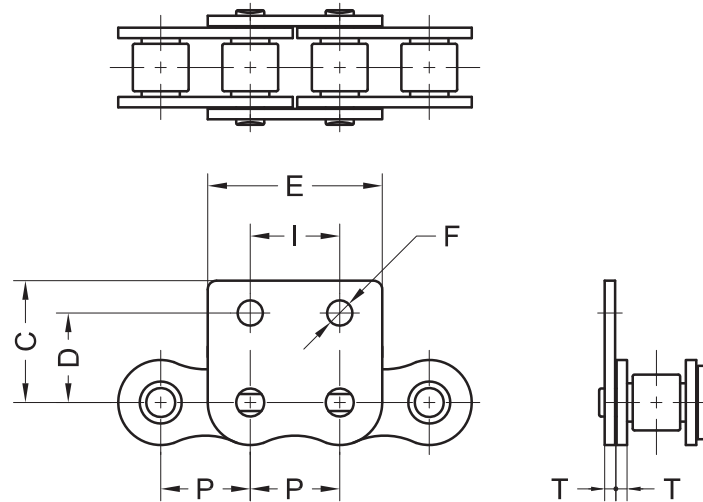

WSK-2

Wide contour straight two sides with two holes in each tab

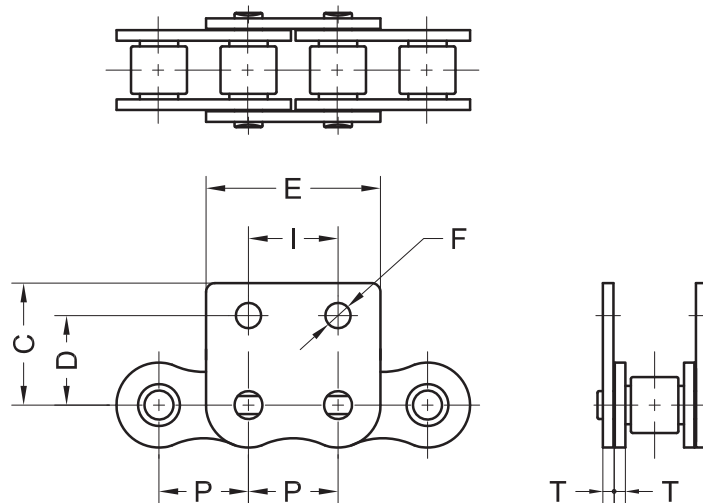

Dimensions: inch

Chain No.	Pitch	Attachment dimensions						
		P	C	D	E	F	I	T1
06B	0.375	0.535	0.375	0.701	0.102	0.375	0.039	0.050
08B	0.500	0.742	0.526	0.963	0.169	0.500	0.059	0.062
10B	0.625	0.904	0.650	1.204	0.209	0.625	0.067	0.067
12B	0.750	1.122	0.844	1.385	0.252	0.750	0.073	0.073
16B	1.000	1.337	0.911	1.815	0.252	1.000	0.125	0.157

ISO BRITISH METRIC STANDARD ATTACHMENTS D-1 DD-1

D-1

One pin extended one side

DD-1

One pin extended two sides

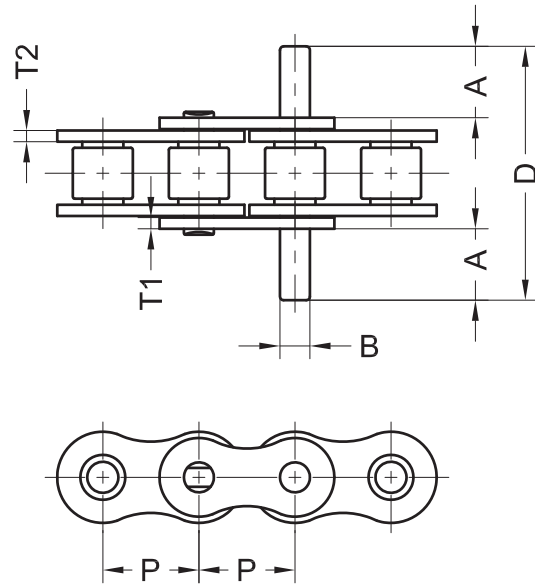
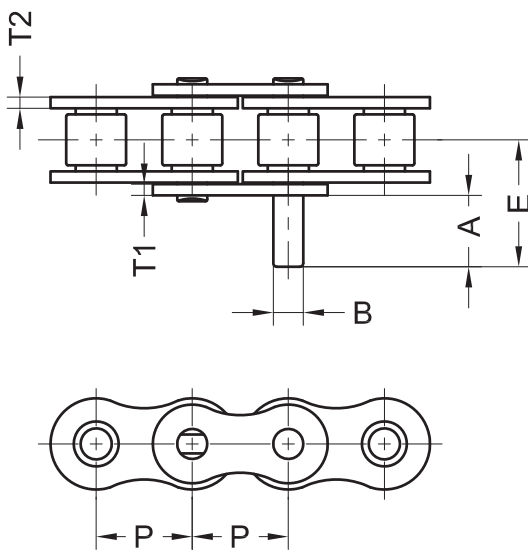

Dimensions: inch

Chain No.	Pitch	Attachment dimensions					
	P	A	B	D	E	T1	T2
06B	0.375	0.480	0.129	1.340	0.670	0.039	0.050
08B	0.500	0.610	0.175	1.760	0.880	0.059	0.062
10B	0.625	0.728	0.200	2.096	1.048	0.065	0.065
12B	0.750	0.846	0.225	2.436	1.218	0.071	0.071
16B	1.000	1.358	0.326	3.874	1.937	0.122	0.157
20B	1.250	1.551	0.401	4.360	2.180	0.122	0.173
24B	1.500	2.024	0.576	5.788	2.894	0.185	0.236

ISO BRITISH METRIC STANDARD

ATTACHMENTS D-3 DD-3

D-3

Two pins extended one side

DD-3

Two pins extended two sides

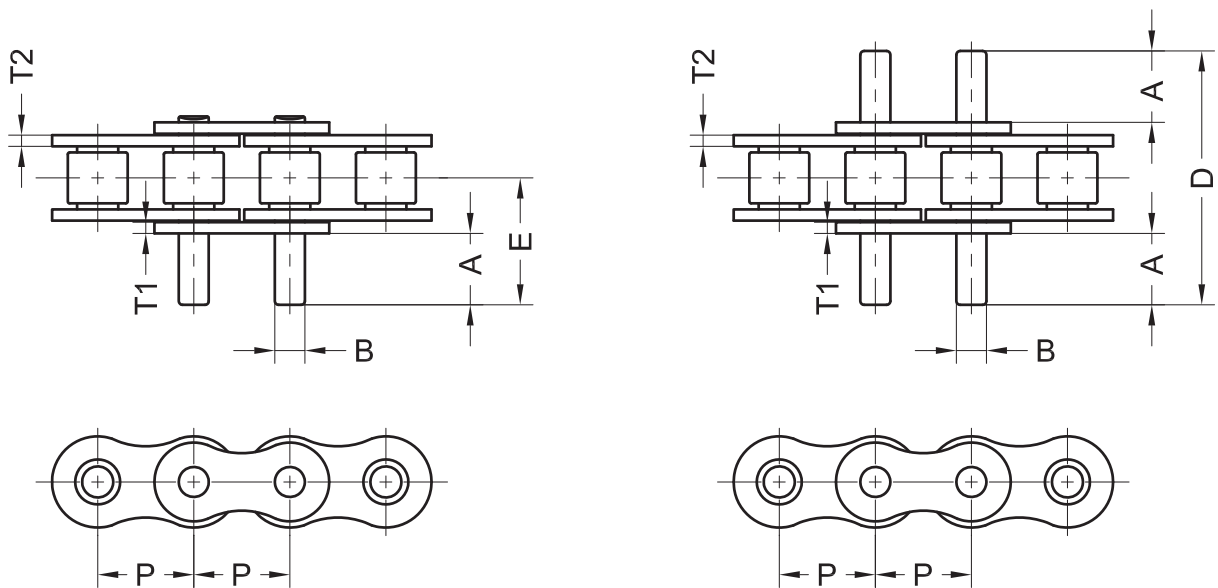

Dimensions: inch

Chain No.	Pitch	Attachment dimensions					
	P	A	B	D	E	T1	T2
06B	0.375	0.480	0.129	1.340	0.67	0.039	0.050
08B	0.500	0.610	0.175	1.760	0.880	0.059	0.062
10B	0.625	0.728	0.200	2.096	1.048	0.065	0.065
12B	0.750	0.846	0.225	2.436	1.218	0.071	0.071
16B	1.000	1.358	0.326	3.874	1.937	0.122	0.157
20B	1.250	1.551	0.401	4.360	2.180	0.122	0.173
24B	1.500	2.024	0.576	5.788	2.894	0.185	0.236



SPECIALTY CHAIN

Our PEER Chain ANSI/ASME roller chains provide solutions to many of your application needs. When you are unable to utilize a standard chain, we are here to help find the solution for you. PEER Chain offers specialized chains to meet many demanding industry needs. In in this guide, you will discover solutions to your needs such as hollow pin, side bow, snap-on top, o-ring, bindery, wrench chain, and many more. Unique challenges require unique solutions. Contact us when you are not able to find a standard chain to suit your application, and we will find a solution to align with your specific performance requirements.



Cryptogram

A	B	C	D	E	F	G	H	I	J	K	L	M	N	O	P	Q	R	S	T	U	V	W	X	Y	Z
24	1	20	15	3	21	7	26	6	18	16	22	11	4	2	5	19	9	8	13	17	10	12	23	14	25

$\frac{\quad}{2}$ $\frac{\quad}{17}$ $\frac{\quad}{9}$ $\frac{\quad}{13}$ $\frac{\quad}{3}$ $\frac{\quad}{24}$ $\frac{\quad}{11}$ $\frac{\quad}{26}$ $\frac{\quad}{3}$ $\frac{\quad}{22}$ $\frac{\quad}{5}$ $\frac{\quad}{8}$

$\frac{\quad}{14}$ $\frac{\quad}{2}$ $\frac{\quad}{17}$ $\frac{\quad}{9}$ $\frac{\quad}{13}$ $\frac{\quad}{3}$ $\frac{\quad}{24}$ $\frac{\quad}{11}$

$\frac{\quad}{3}$ $\frac{\quad}{8}$ $\frac{\quad}{20}$ $\frac{\quad}{24}$ $\frac{\quad}{5}$ $\frac{\quad}{3}$ $\frac{\quad}{13}$ $\frac{\quad}{2}$ $\frac{\quad}{13}$ $\frac{\quad}{26}$ $\frac{\quad}{3}$

$\frac{\quad}{8}$ $\frac{\quad}{2}$ $\frac{\quad}{22}$ $\frac{\quad}{17}$ $\frac{\quad}{13}$ $\frac{\quad}{6}$ $\frac{\quad}{2}$ $\frac{\quad}{4}$ $\frac{\quad}{8}$ $\frac{\quad}{13}$ $\frac{\quad}{26}$ $\frac{\quad}{24}$ $\frac{\quad}{13}$

$\frac{\quad}{8}$ $\frac{\quad}{17}$ $\frac{\quad}{6}$ $\frac{\quad}{13}$ $\frac{\quad}{14}$ $\frac{\quad}{2}$ $\frac{\quad}{17}$ $\frac{\quad}{9}$ $\frac{\quad}{4}$ $\frac{\quad}{3}$ $\frac{\quad}{3}$ $\frac{\quad}{15}$ $\frac{\quad}{8}$

**At the beginning of each Escape Room, you will find a puzzle. Solve each puzzle to find the cryptic message in each Escape Room. Once you have completed the puzzles, visit our website (peerchain.com) and search for the discrete door and enter! Once you complete the form, what follows is all about our relationship with you!*

HOLLOW-PIN CHAIN



1. All PEER hollow-pin chains are **manufactured** with **precision**.
2. PEER hollow-pin chain provides a **multitude** of possibilities for **attachments** and **cross-rod spacing**.
3. Ideal for **easy assembly** and disassembly of attachments.

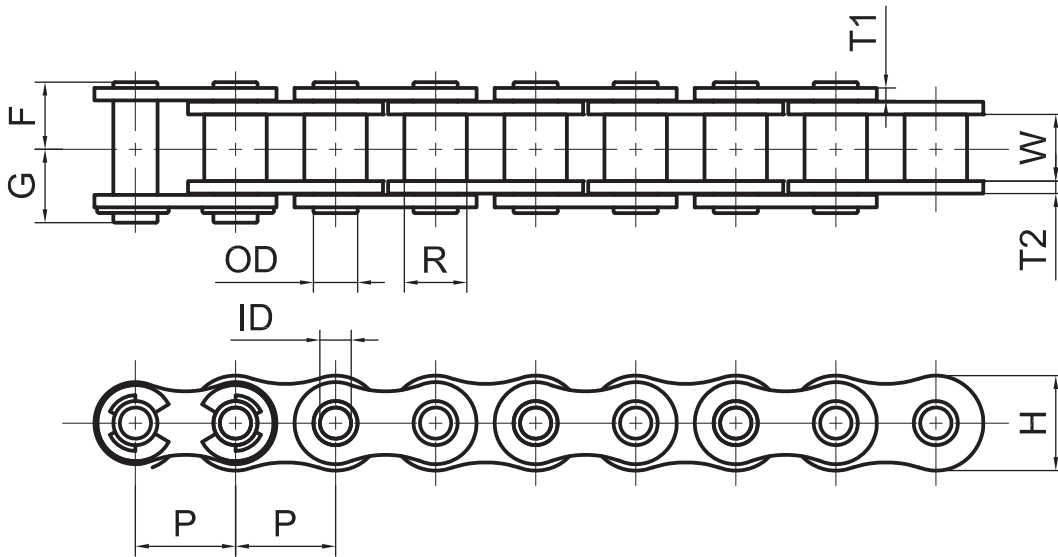

Dimensions: inch

Chain No.	Pitch	Bushing		Hollow Pin		Plate			Overall Width		Avg. Ult. Tensile Strength (Lbs.)	Max. Working Load (Lbs.)	Avg. Weight Per Foot
		Width	Dia.	Inside Dia.	Outside Dia.	Height	Thickness		F	G			
		W	R	ID	OD	H	T1	T2					
40HP	0.500	0.312	0.312	0.157	0.225	0.475	0.060	0.060	0.330	0.357	2,977	440	0.36
50HP	0.625	0.375	0.400	0.202	0.287	0.594	0.080	0.080	0.408	0.459	4,741	700	0.58
60HP	0.750	0.500	0.469	0.235	0.331	0.712	0.094	0.094	0.513	0.553	6,064	900	0.86
80HP	1.000	0.625	0.625	0.313	0.450	0.950	0.125	0.125	0.662	0.699	11,576	1710	1.48
08BHP	0.500	0.305	0.335	0.177	0.242	0.465	0.059	0.067	0.324	0.368	2,867	425	0.44
10BHP	0.625	0.380	0.400	0.202	0.287	0.580	0.067	0.067	0.383	0.430	4,079	600	0.54
12BHP	0.750	0.460	0.475	0.197	0.276	0.635	0.073	0.073	0.441	0.522	4,741	710	0.77

HOLLOW-PIN DOUBLE PITCH CHAIN



1. All PEER hollow-pin chains are **manufactured** with **precision**.
2. PEER hollow-pin chain provides a **multitude** of possibilities for **attachments** and **cross-rod spacing**.
3. Ideal for **easy assembly** and disassembly of attachments.

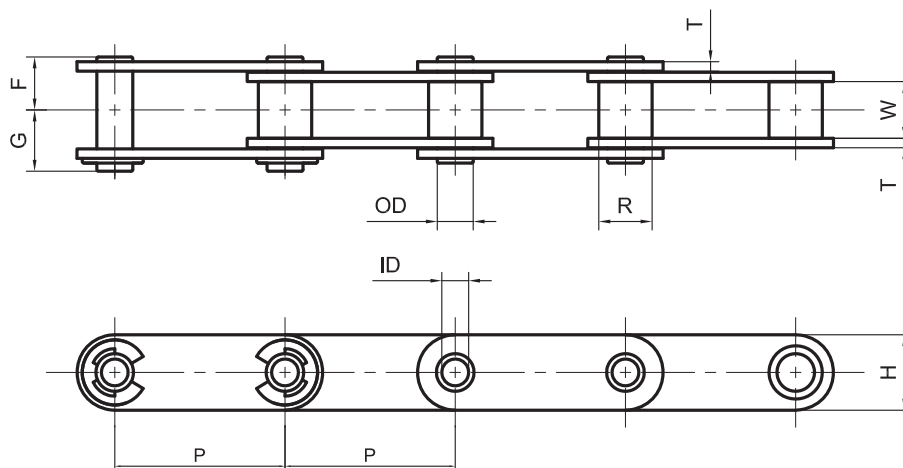

Dimensions: inch

Chain No.	Pitch P	Bushing		Roller	Hollow Pin		Plate		Overall Width		Avg. Ult. Tensile Strength (Lbs.)	Max Working Load (Lbs.)	Avg. Weight Per Foot
		Width	Dia.	Dia.	Inside Dia.	Outside Dia.	Height	Thickness	F	G			
		W	R1	R2	ID	OD	H	T					
C2040HP	1.000	0.312	0.312	-	0.157	0.225	0.463	0.060	0.330	0.357	2,976	440	0.316
C2042HP	1.000	0.312	-	0.625	0.157	0.225	0.463	0.060	0.330	0.357	2,976	440	0.558
C2050HP	1.250	0.375	0.400	-	0.202	0.287	0.594	0.080	0.408	0.459	4,740	700	0.538
C2052HP	1.250	0.375	-	0.750	0.202	0.287	0.594	0.080	0.408	0.459	4,740	700	0.853
C2060HP	1.500	0.500	0.469	-	0.235	0.331	0.712	0.094	0.513	0.553	6,063	900	0.759
C2062HP	1.500	0.500	-	0.875	0.235	0.331	0.712	0.094	0.513	0.553	6,063	900	0.947
C2080HP	2.000	0.625	0.625	-	0.313	0.450	0.950	0.125	0.662	0.699	11,574	1,700	1.144
C2082HP	2.000	0.625	-	1.125	0.313	0.450	0.950	0.125	0.662	0.699	11,574	1,700	1.854
C2060H HP	1.500	0.500	0.469	-	0.235	0.331	0.712	0.125	0.567	0.606	5,842	850	0.947
C2062H HP	1.500	0.500	-	0.875	0.235	0.331	0.712	0.125	0.567	0.606	5,842	850	1.431
C2080H HP	2.000	0.625	0.625	-	0.313	0.450	0.950	0.156	0.744	0.709	11,354	1,700	1.599
C2082H HP	2.000	0.625	-	1.125	0.313	0.450	0.950	0.156	0.744	0.709	11,354	1,700	2.318
C2120H HP	3.000	1.000	0.875	-	0.441	0.631	1.369	0.217	1.081	1.120	25,419	3,800	3.481
C2122H HP	3.000	1.000	-	1.750	0.441	0.639	1.369	0.217	1.081	1.120	25,420	3,800	5.436

SIDE BOW CHAIN



1. All PEER sidebow chains incorporate **tapered bushings**.
2. **Increased clearance** between pins, bushings, and sideplates allow for extra side bow.
3. Provides **greater flexibility** on curved tracks.

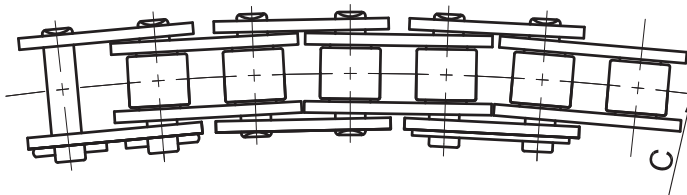
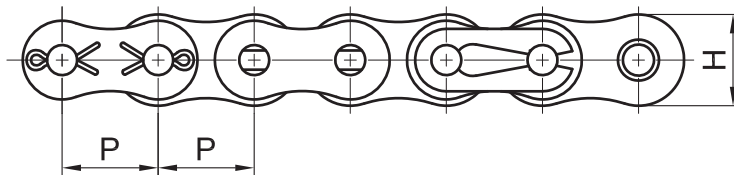
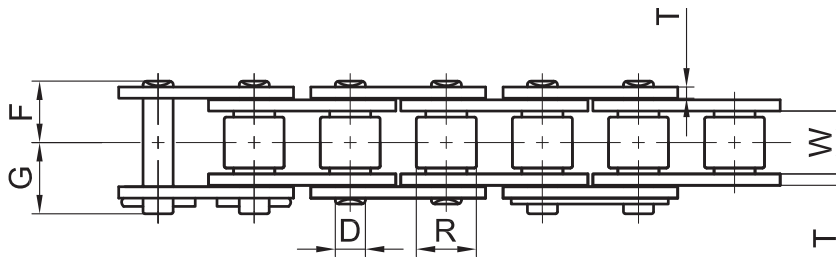

Dimensions: inch

Chain No.	Pitch P	Roller		Plate		Pin Dia. D	Overall Width		Min Radius of Curve C	Avg. Ult. Tensile Strength (Lbs.)	Max. Working Load (Lbs.)	Avg. Weight Per Foot (Lbs.)
		Width W	Dia. R	Height H	Thickness T		F	G				
35 SB	0.375	0.188	0.200	0.356	0.050	0.142	0.232	0.303	10.625	2,360	230	0.215
40 SB	0.500	0.312	0.312	0.475	0.060	0.157	0.336	0.419	14.000	3,520	420	0.417
50 SB	0.625	0.375	0.400	0.594	0.080	0.200	0.415	0.526	16.000	5,500	650	0.679
60 SB	0.750	0.500	0.469	0.712	0.094	0.235	0.526	0.627	20.000	7,700	910	0.974
80 SB	1.000	0.625	0.625	0.950	0.125	0.313	0.701	0.835	24.000	14,500	1,700	1.714

SIDE BOW DOUBLE PITCH CHAIN



1. All PEER sidebow chains incorporate **tapered bushings**.
2. **Increased clearance** between pins, bushings, and sideplates allow for extra side bow.
3. Provides **greater flexibility** on curved tracks.

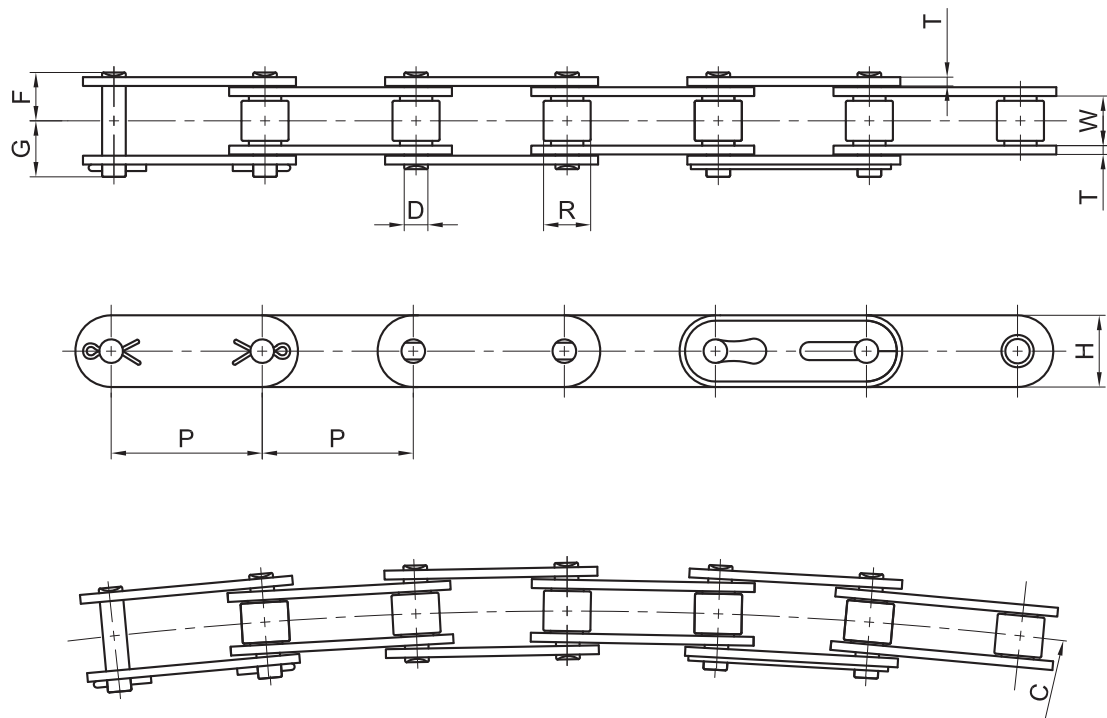

Dimensions: inch

Chain No.	Pitch	Roller		Plate		Pin Dia.	Overall Width		Min Radius of Curve	Avg. Ult. Tensile Strength (Lbs.)	Max. Working Load (Lbs.)	Avg. Weight Per Foot (Lbs.)
		Width	Dia.	Height	Thickness		F	G				
C2040 SB	1.000	0.312	0.312	0.463	0.060	0.157	0.335	0.419	27000	3,520	420	0.318
C2050 SB	1.250	0.375	0.400	0.594	0.080	0.200	0.415	0.526	31,496	5,500	650	0.541
C2060 SB	1.500	0.500	0.469	0.712	0.094	0.235	0.526	0.627	39,000	7,700	910	0.763
C2080 SB	2.000	0.625	0.625	0.950	0.125	0.313	0.681	0.835	47,000	14,520	1,700	1.400

SNAP-ON TOP CHAIN



1. PEER Snap-On chains are available in **standard** or **side bow** configurations.
2. The **rivetless pins are extended** to accommodate attachments and easily “snap” on or off.
3. Chains are available in Carbon Steel, Nickel-Plated, and Stainless Steel.

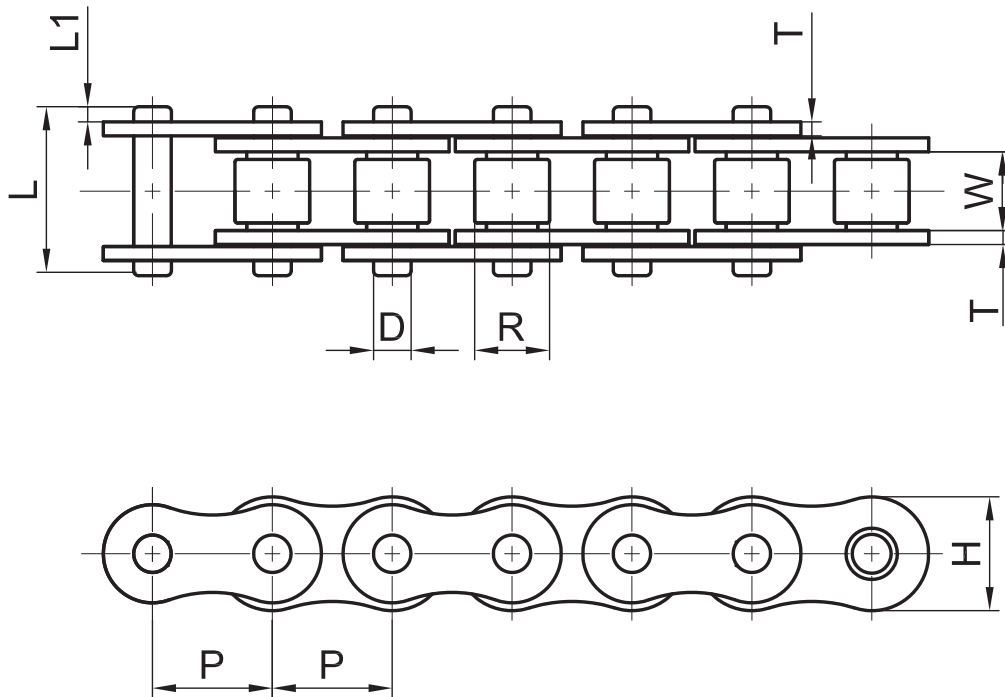

Dimensions: inch

Chain No.	Pitch P	Roller		Plate		Pin Dia. D	Overall Width		Avg. Ult. Tensile Strength (Lbs.)	Max. Working Load (Lbs.)	Avg. Weight Per Foot (Lbs.)
		Width W	Dia. R	Height H	Thickness T		L	G			
		43	0.500	0.312	0.312		0.463	0.060			
43NP	0.500	0.312	0.312	0.463	0.060	0.157	0.704	0.065	4,070	810	0.460
43SS	0.500	0.312	0.312	0.463	0.060	0.157	0.704	0.065	2,200	440	0.460
43PHSS	0.500	0.312	0.312	0.463	0.060	0.157	0.704	0.065	2,860	570	0.460
63	0.750	0.500	0.469	0.685	0.094	0.235	1.110	0.104	9,130	1,800	1.090
63NP	0.750	0.500	0.469	0.685	0.094	0.235	1.110	0.104	9,130	1,800	1.090
63SS	0.750	0.500	0.469	0.685	0.094	0.235	1.110	0.104	5,500	1,100	1.090
63PHSS	0.750	0.500	0.469	0.685	0.094	0.235	1.110	0.104	7,040	1,400	1.090

SIDE BOW SNAP-ON TOP CHAIN



1. PEER Snap-On chains are available in **standard** or **side bow** configurations.
2. The **rivetless pins are extended** to accommodate attachments and easily “snap” on or off.
3. Chains are available in Carbon Steel, Nickel-Plated, and Stainless Steel.

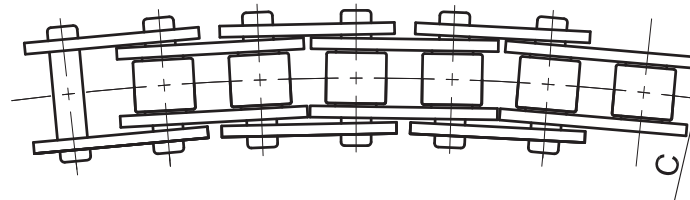
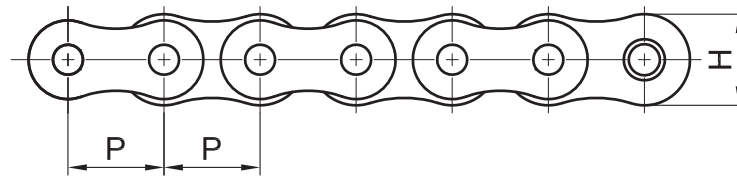
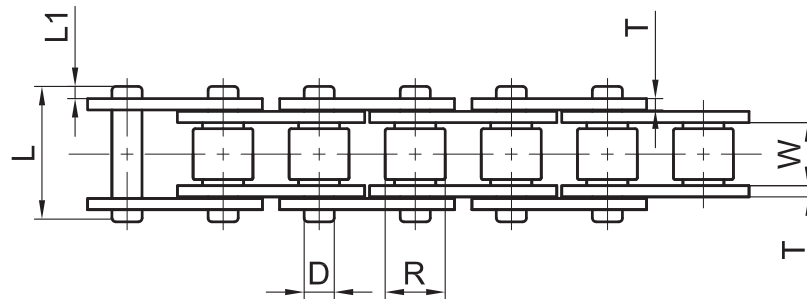

Dimensions: inch

Chain No.	Pitch P	Roller		Plate		Pin Dia. D	Overall Width		Min Radius of Curve C	Avg. Ult. Tensile Strength (Lbs.)	Max. Working Load (Lbs.)	Avg. Weight Per Foot (Lbs.)
		Width W	Dia. R	Height H	Thickness T		L	G				
		43 SB	0.500	0.312	0.312		0.463	0.060				
43NP SB	0.500	0.312	0.312	0.463	0.060	0.136	0.724	0.070	12.000	2,750	330	0.430
43SS SB	0.500	0.312	0.312	0.463	0.060	0.136	0.724	0.070	12.000	1,650	190	0.430
43PHSS SB	0.500	0.312	0.312	0.463	0.060	0.136	0.724	0.070	12.000	2,200	260	0.430
63 SB	0.750	0.500	0.469	0.685	0.094	0.200	1.140	0.120	14.000	6,050	720	1.010
63NP SB	0.750	0.500	0.469	0.685	0.094	0.200	1.140	0.120	14.000	6,050	720	1.010
63SS SB	0.750	0.500	0.469	0.685	0.094	0.200	1.140	0.120	14.000	3,630	460	1.010
63PHSS SB	0.750	0.500	0.469	0.685	0.094	0.200	1.140	0.120	14.000	4,840	580	1.010



1. Synthetic rubber O-Rings **seal in lubricant** within the bearing area of the chain.
2. Ideal for applications where keeping dirt and other **contaminants out** of the bearing area are critical.
3. Commonly used where continuous re-lubrication can be difficult.
4. All O-Ring chain has quad-staked pins to allow **greater pin push-out** force.

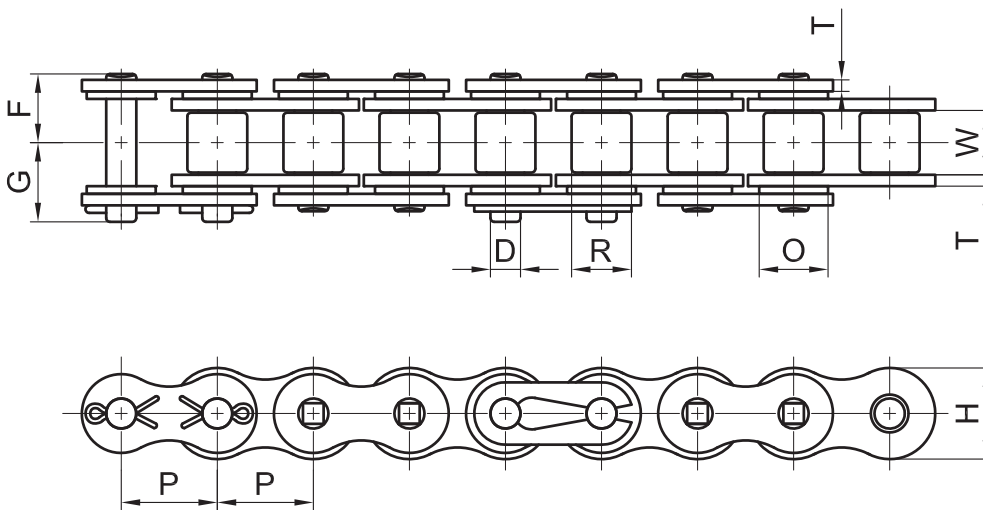

Dimensions: inch

Chain No.	Pitch	Roller		Plate		Pin Dia.	Overall Width		Avg. Ult. Tensile Strength (Lbs.)	Max. Working Load (Lbs.)	Avg. Weight Per Foot (Lbs.)
		Width	Dia.	Height	Thickness		F	G			
	P	W	R	H	T	D	F	G			
40 O-Ring	0.500	0.312	0.312	0.475	0.060	0.157	0.357	0.412	4,180	500	0.420
50 O-Ring	0.625	0.375	0.400	0.594	0.080	0.200	0.458	0.475	6,900	800	0.700
60 O-Ring	0.750	0.500	0.469	0.712	0.094	0.235	0.546	0.585	10,300	1,225	1.000
80 O-Ring	1.000	0.625	0.625	0.950	0.125	0.313	0.690	0.766	17,900	2,150	1.900
100 O-Ring	1.250	0.750	0.750	1.187	0.156	0.376	0.843	1.035	27,500	3,300	2.350
120 O-Ring	1.500	1.000	0.875	1.425	0.187	0.437	1.114	1.240	36,000	4,250	4.400

TOP ROLLER CHAIN

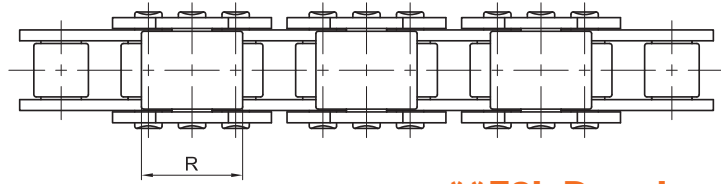

****E2L Drawing Shown**

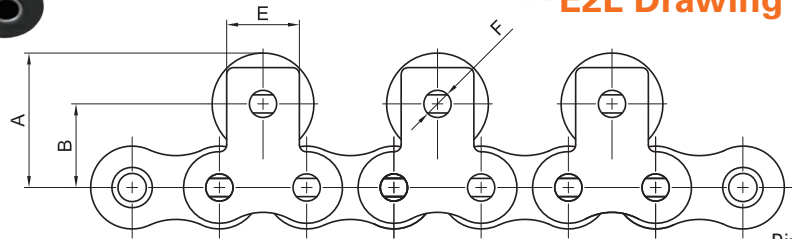

Dimensions: inch

Chain No.	Pitch P	Top Roller				Top Roller Diameter		*EL Avg. Weight Per Foot (Lbs.)	**E2L Avg. Weight Per Foot (Lbs.)
		Height A	Center B	Face E	Pin Dia F	*EL R	**E2L R		
60	0.625	1.031	0.719	0.625	0.235	0.709	0.875	2.45	2.27
80	1.000	1.341	0.969	0.750	0.313	0.945	1.125	4.10	3.97
100	1.250	1.752	1.252	1.000	0.376	1.181	1.562	6.25	5.81

*EL Top Roller Every Link

**E2L Top Roller Every Second Link

1. Top Roller Chains are typically used in **transfer systems**.
2. Top Rollers are available with **steel or plastic materials**.

TOP ROLLER DOUBLE PITCH CHAIN

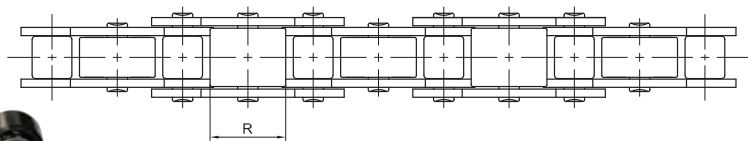

***EL Drawing Shown**

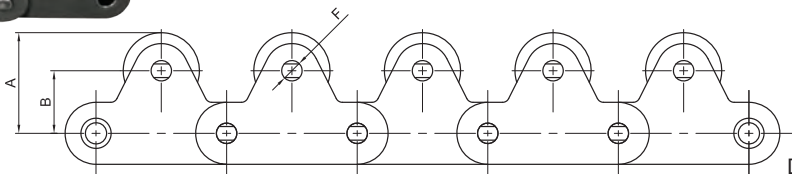

Dimensions: inch

Chain No.	Pitch P	Top Roller			Top Roller Diameter R	Avg. Weight Per Foot (Lbs.)
		Height A	Center B	Pin Dia. F		
C2060H	1.500	1.004	0.689	0.235	0.875	2.15
C2062H	1.500	1.316	1.001	0.235	0.875	3.00
C2080H	2.000	1.594	1.142	0.437	1.125	3.80
C2082H	2.000	1.594	1.142	0.437	1.125	4.55
C2100H	2.500	1.957	1.394	0.563	1.562	6.15
C2102H	2.500	1.957	1.394	0.563	1.562	7.70

DOUBLE CAPACITY CHAIN

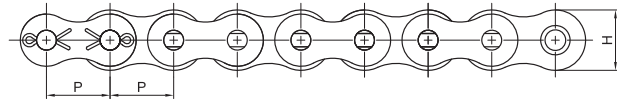
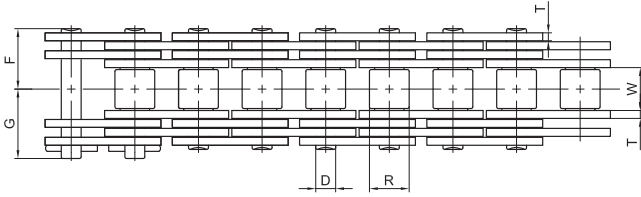

Dimensions: inch

Chain No.	Pitch	Roller		Plate		Pin Dia.	Overall Width		Avg. Ult. Tensile Strength (Lbs.)	Max. Working Load (Lbs.)	Avg. Weight Per Foot (Lbs.)
		Width	Dia.	Height	Thickness		F	G			
	P	W	R	H	T	D	F	G			
60 DC	0.750	0.500	0.469	0.712	0.094	0.235	0.695	0.795	18,920	2,250	1.62
80 DC	1.000	0.625	0.625	0.950	0.125	0.313	0.898	0.959	35,970	4,250	3.02
100 DC	1.250	0.750	0.750	1.187	0.156	0.376	1.098	1.171	58,630	7,000	4.66
120 DC	1.500	1.000	0.875	1.425	0.187	0.437	1.358	1.443	77,550	9,200	6.63
140 DC	1.750	1.000	1.000	1.662	0.219	0.500	1.504	1.596	101,200	12,100	8.70
160DC	2.000	1.250	1.125	1.900	0.250	0.563	1.772	1.872	128,700	14,150	11.44
180 DC	2.250	1.406	1.406	2.137	0.281	0.687	2.000	2.120	171,600	18,850	14.84
200 DC	2.500	1.500	1.562	2.375	0.312	0.781	2.189	2.362	247,500	27,225	18.33
240 DC	3.000	1.875	1.875	2.850	0.375	0.937	2.669	2.819	312,400	34,330	28.26



1. PEER Double Capacity Roller Chain incorporates **twice the link plates** per chain to double the chain's rated capacity.
2. Employs PEER Quest™ chain technology: Solid, one-piece cold formed bushings which **improves wear resistance** and provides **superior defiance to elongation**.
3. Commonly used in tension linkage applications, such as **high load hoists** and **severe duty drives** operating at slow to medium speed.

DOUBLE CAPACITY DOUBLE PITCH CHAIN

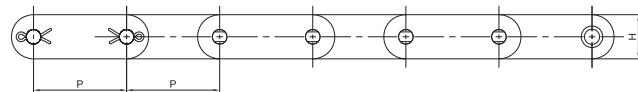
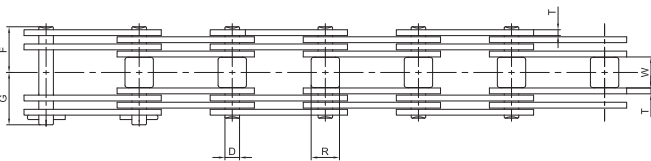

Dimensions: inch

Chain No.	Pitch	Roller		Plate		Pin Dia.	Overall Width		Avg. Ult. Tensile Strength (Lbs.)	Max. Working Load (Lbs.)	Avg. Weight Per Foot (Lbs.)
		Width	Dia.	Height	Thickness		F	G			
	P	W	R	H	T	D	F	G			
C2060H DC	1.500	1.000	0.469	0.712	0.125	0.235	0.829	0.925	24,200		1.71

BINDERY CHAIN 12B

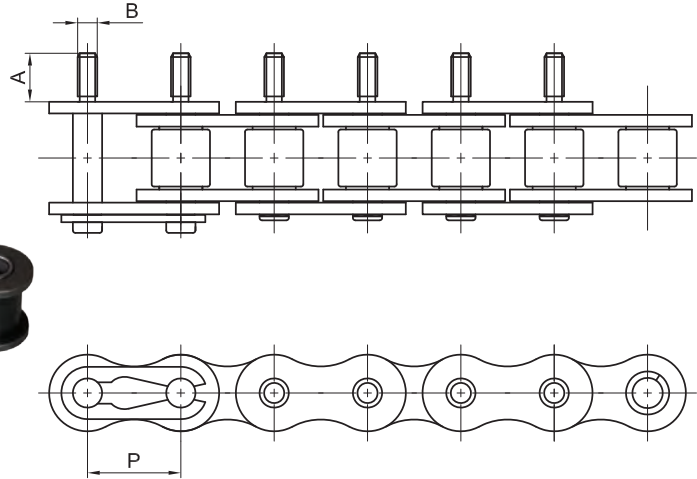

Dimensions: inch

Chain No.	Pitch	Bindery Attachment		Avg. Weight Per Foot (Lbs.)
	P	A	B	
12B Bindery	0.750	0.390	M4 x 0.7P	0.90

1. Commonly used in book binding applications.

BINDERY CHAIN 40R

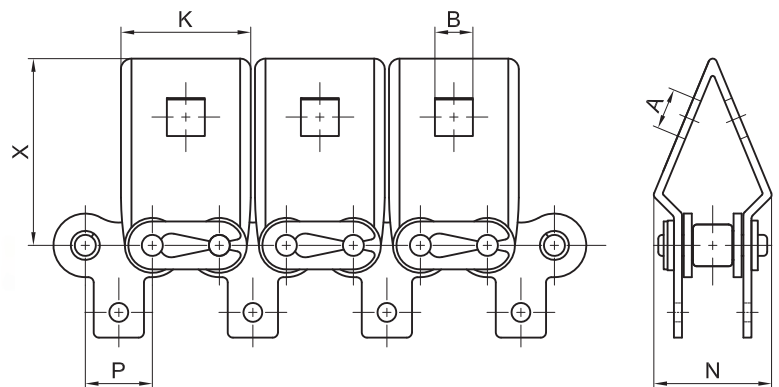

Dimensions: inch

Chain No.	Pitch	Bindery Attachment					Avg. Weight Per Foot (Lbs.)
	P	K	X	N	A	B	
40 Bindery	0.500	0.970	1.390	0.838	0.283	0.283	1.20



1. PEER wrench chain is commonly used to hold or turn smooth, circular objects such as pipe or car parts.

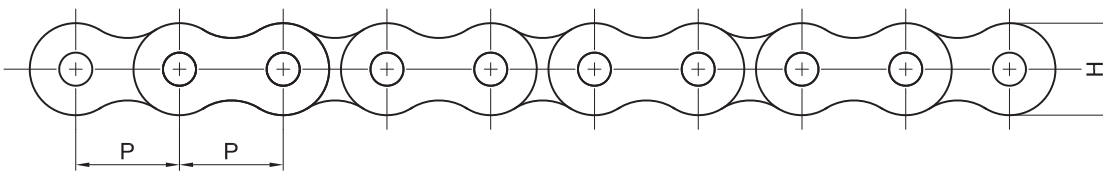
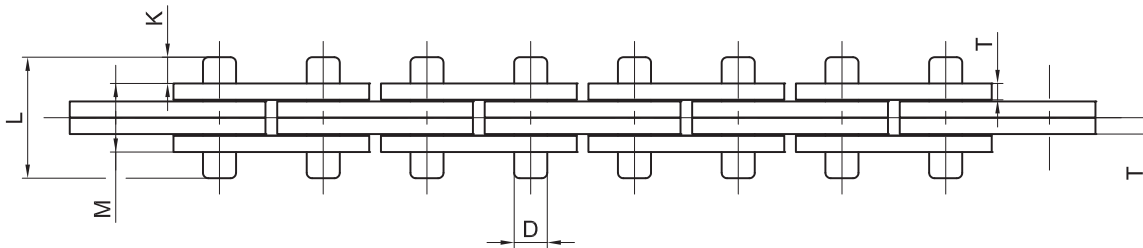

Dimensions: inch

Chain No.	Pitch	Lacing	Plate		Pin Dia.	Overall Width			Avg. Ult. Tensile Strength (Lbs.)	Avg. Weight Per Foot (Lbs.)
			Height	Thickness		L	K	M		
	P		H	T	D					
5/8WR	0.625	2 X 2	0.500	0.077	0.200	0.688	0.172	0.344	6,600	0.410
3/4WR	0.750	2 X 2	0.667	0.118	0.240	0.875	0.178	0.520	12,000	0.950

POLY STAINLESS STEEL CHAIN



1. All PEER Chain Poly Chain incorporates **plastic roller** links with **304 stainless steel pin link plates**.
2. The combination of stainless steel and plastic **prevent the need for lubrication**.
3. Poly Chain is commonly used in both **drive and conveyance applications**.

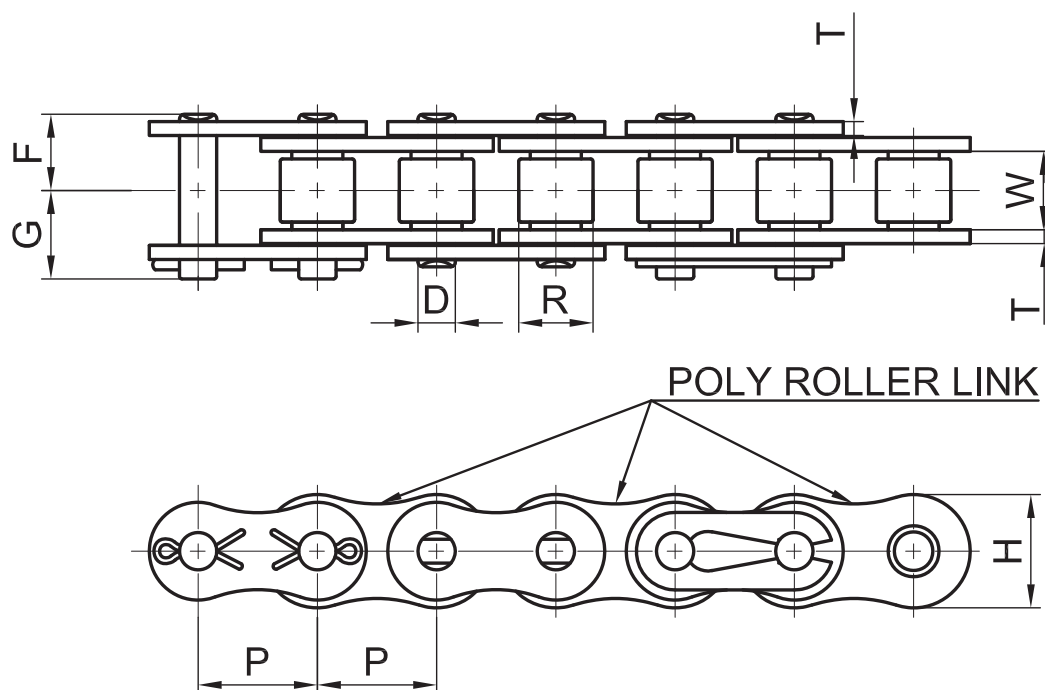

Dimensions: inch

Chain No.	Pitch P	Roller		Plate		Pin Dia. D	Overall Width		Max. Working Load (Lbs.)	Avg. Weight Per Foot (Lbs.)
		Width W	Dia. R	Height H	Thickness T		F	G		
		40 Poly	0.500	0.309	0.312		0.465	0.060		
50 Poly	0.625	0.370	0.400	0.579	0.080	0.200	0.407	0.470	150	0.550
60 Poly	0.750	0.495	0.469	0.701	0.094	0.234	0.504	0.581	200	0.700

NON-STANDARD ROLLER CHAIN



1. Non-Standard roller chains are ANSI/ASME base chains with modified dimensions to **meet demanding applications**.
2. All chain components are **heat-treated** to achieve maximum strength and greater wear resistance.
3. All PEER roller chain is **pre-loaded** during the manufacturing process to minimize initial elongation.
4. **Hot-dipped lubrication** ensures 100% lubrication of all chain components to extend wear life and reduce maintenance costs.

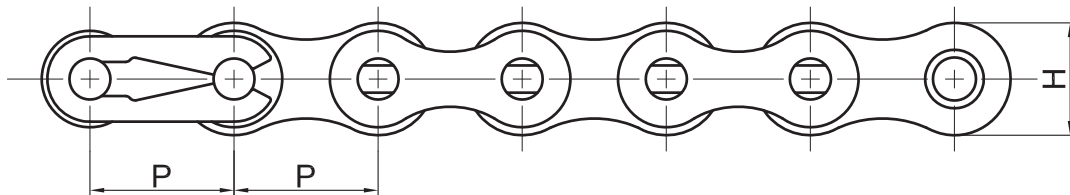
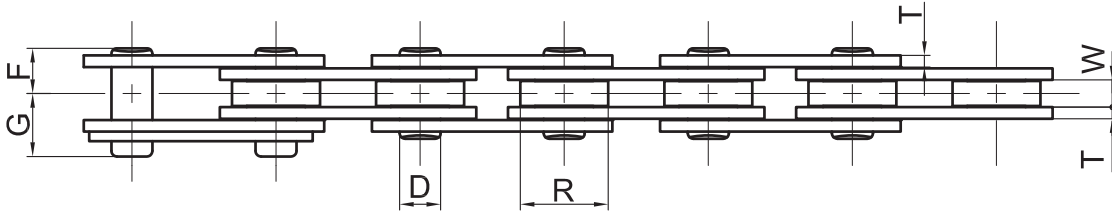

Dimensions: inch

Chain No.	Pitch P	Roller		Plate		Pin Dia. D	Overall Width		Avg. Ult. Tensile Strength (Lbs.)	Avg. Weight Per Foot (Lbs.)
		Width W	Dia. R	Height H	Thickness T		F	G		
410	0.500	0.125	0.306	0.390	0.039	0.142	0.184	0.233	1,900	0.190
408	0.500	0.094	0.306	0.390	0.039	0.142	0.149	0.190	1,900	0.180
415	0.500	0.188	0.306	0.390	0.039	0.142	0.216	0.262	2,100	0.240
415H	0.500	0.188	0.306	0.469	0.060	0.156	0.263	0.301	3,700	0.330
420	0.500	0.250	0.306	0.469	0.060	0.156	0.288	0.344	3,700	0.380
423	0.500	0.250	0.335	0.469	0.060	0.176	0.288	0.338	4,600	0.420
428	0.500	0.312	0.335	0.469	0.060	0.176	0.324	0.371	4,600	0.440
428H	0.500	0.313	0.335	0.476	0.071	0.176	0.350	0.392	5,300	0.550
520	0.625	0.250	0.400	0.585	0.079	0.200	0.344	0.394	6,100	0.640
525	0.625	0.312	0.400	0.585	0.079	0.200	0.376	0.425	6,100	0.680

ROLLERLESS CHAIN



1. Rollerless chains are assembled **without the roller** and have the same dimensional and tensile strengths as standard ANSI/ASME chains.
2. All chain components are **heat-treated** to achieve maximum strength and greater wear resistance.
3. All PEER roller chain is **pre-loaded** during the manufacturing process to minimize initial elongation.
4. **Hot-dipped lubrication** ensures 100% lubrication of all chain components to extend wear life and reduce maintenance costs.

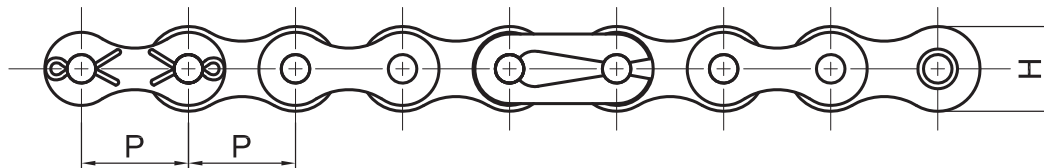
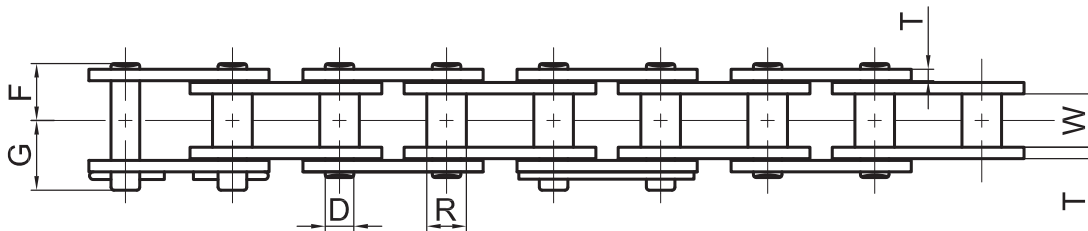

Dimensions: inch

Chain No.	Pitch P	Bushing		Plate		Pin Dia. D	Overall Width		Avg. Ult. Tensile Strength (Lbs.)	Avg. Weight Per Foot (Lbs.)
		Width W	Dia. R	Height H	Thickness T		F	G		
55	0.625	0.375	0.278	0.594	0.080	0.200	0.400	0.488	6,834	0.600
65	0.750	0.500	0.330	0.712	0.094	0.235	0.501	0.601	9,259	0.836
85	1.000	0.625	0.443	0.950	0.125	0.313	0.650	0.803	17,636	1.486
105	1.250	0.750	0.535	1.187	0.156	0.376	0.781	0.950	25,353	2.386
125	1.500	1.000	0.627	1.425	0.187	0.437	1.005	1.174	34,392	3.103



B Style Shown

- Block chain is available in three configurations:
 - B:** solid blocks made of powdered metal
 - BL:** laminated blocks made of steel plates
 - BLSS:** laminated blocks made of stainless steel
- Block Chains are used in **low speed** and **light-weight conveyance** applications.

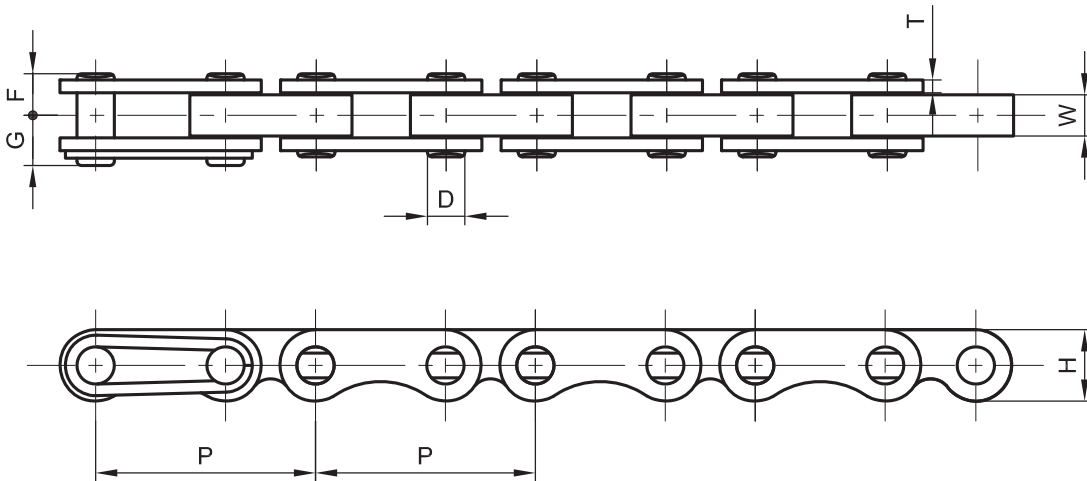

Dimensions: inch

Chain No.	Pitch	Block	Plate		Pin Dia.	Overall Width		Avg. Ult. Tensile Strength (Lbs.)	Avg. Weight Per Foot (Lbs.)
		Width	Height	Thickness		F	G		
	P	W	H	T	D	F	G		
502B	1.000	0.187	0.325	0.059	0.170	0.189	0.228	1,300	0.230
503B	1.000	0.250	0.325	0.059	0.170	0.222	0.262	1,500	0.264
504B	1.000	0.313	0.325	0.079	0.187	0.279	0.320	1,500	0.329
505B	1.000	0.375	0.325	0.079	0.187	0.311	0.350	1,975	0.371
506B	1.000	0.500	0.325	0.079	0.187	0.373	0.412	1,975	0.444



LEAF CHAIN

Leaf chains are known for their durability and high tensile strength. They are primarily used in lift device applications such as forklifts, lift trucks, and lift masts. These hard working chains handle the lifting and balancing of heavy loads with the use of sheaves instead of sprockets for guidance. One of the primary differences with leaf chain compared to roller chain is that it only consists of a series of stacked link plates and pins. With the proper selection of steel and heat treatment of the link plates and pins, PEER Chain can assist with the Leaf Chain Design to elevate your product needs.



Maze

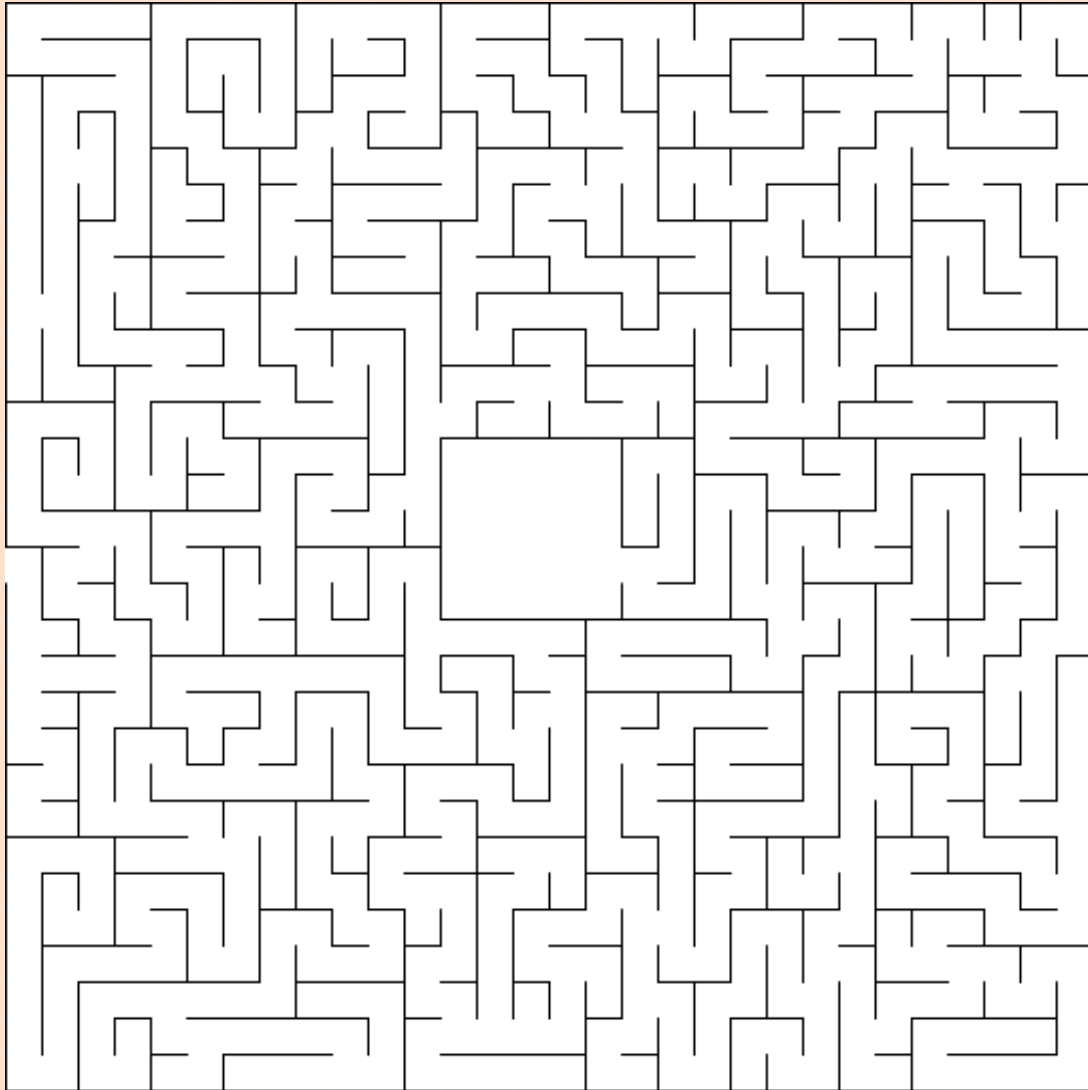

**At the beginning of each Escape Room, you will find a puzzle. Solve each puzzle to find the cryptic message in each Escape Room. Once you have completed the puzzles, visit our website (peerchain.com) and search for the discrete door and enter! Once you complete the form, what follows is all about our relationship with you!*

LEAF CHAIN

AL SERIES

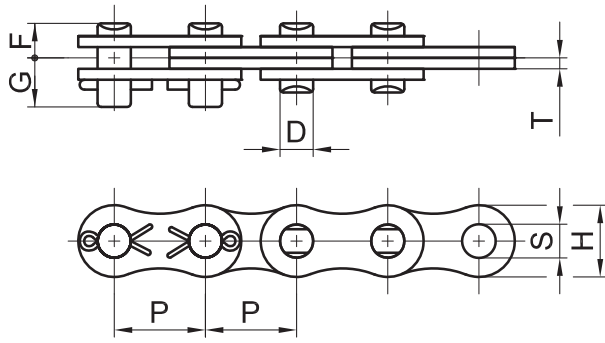

- Primarily used for **lifting** and **hoist applications** such as on fork lifts, lift trucks, and container lifts.
- Constructed with **stacked plates** and **pins**.
- Leaf chains provide **high strength** and **high load** for lift applications.
- PEER Chain recommends the use of BL Series Leaf Chain for more **demanding applications**.

Dimensions: inch

Chain No.	Lacing	Pitch	Pin Dia.	Plate		Overall Width		Avg. Ult. Tensile Strength (Lbs.)	Avg. Weight Per Foot (Lbs.)		
				Height	Thickness	F	G				
				P	D	H	T				
AL222	2 x 2	0.250	0.091	0.197	0.030	0.035	0.134	904	0.060		
AL322	2 x 2	0.375	0.142	0.307	0.050	0.138	0.250	2,260	0.141		
AL344	4 x 4					0.263	0.334			4,519	0.269
AL422	2 x 2	0.500	0.157	0.410	0.060	0.163	0.242	4,078	0.235		
AL444	4 x 4					0.287	0.368			8,157	0.464
AL466	6 x 6					0.408	0.487			12,236	0.692
AL522	2 x 2	0.625	0.200	0.512	0.080	0.212	0.297	6,614	0.390		
AL523	2 x 3					0.253	0.342			6,614	0.484
AL534	3 x 4					0.338	0.430			9,920	0.665
AL544	4 x 4					0.366	0.455			13,227	0.766
AL566	6 x 6					0.535	0.638			19,841	1.136
AL622	2 x 2					0.750	0.235			0.616	0.094
AL623	2 x 3	0.298	0.398	9,039	0.652						
AL644	4 x 4	0.440	0.542	18,078	1.028						
AL666	6 x 6	0.632	0.732	24,117	1.539						
AL688	8 x 8	0.789	0.925	36,155	2.050						
AL822	2 x 2	1.000	0.313	0.820	0.125			0.339	0.457		
AL844	4 x 4					0.589	0.750	34,172	1.888		
AL866	6 x 6					0.898	1.055	51,257	2.822		
AL888	8 x 8					1.116	1.274	68,343	3.743		
AL1022	2 x 2	1.250	0.376	1.025	0.156	0.411	0.555	24,912	1.761		
AL1044	4 x 4					0.742	0.864			49,824	3.152
AL1066	6 x 6					1.059	1.212			74,737	4.697
AL1088	8 x 8					1.385	1.535			99,648	6.243
AL1244	4 x 4	1.500	0.437	1.230	0.187	0.878	1.041	63,934	4.193		
AL1266	6 x 6					1.255	1.449			95,901	6.249
AL1288	8 x 8					1.647	1.840			127,868	8.312
AL1444	4 x 4	1.750	0.500	1.435	0.219	1.015	1.223	94,799	6.149		
AL1466	6 x 6					1.467	1.652			143,300	9.206
AL1488	8 x 8					1.914	2.111			191,140	12.297
AL1644	4 x 4	2.000	0.563	1.640	0.250	1.152	1.337	115,743	7.593		
AL1666	6 x 6					1.674	1.843			173,724	11.356
AL1688	8 x 8					2.189	2.386			251,327	15.186

ANSI/ASME
STANDARD

ANSI/ASME
HEAVY

DOUBLE
PITCH

ISO
BRITISH

CORROSION
RESISTANT

SELF
LUBE

ATTACHMENT
CHAIN

SPECIALTY
CHAIN

LEAF
CHAIN

LEAF CHAIN

BL SERIES



1. Primarily used for **lifting** and **hoist applications** such as on fork lifts, lift trucks, and container lifts.
2. Constructed with **stacked plates** and **pins**.
3. Leaf chains provide **high strength** and **high load** for lift applications.
4. PEER Chain recommends the use of BL Series Leaf Chain for more **demanding applications**.

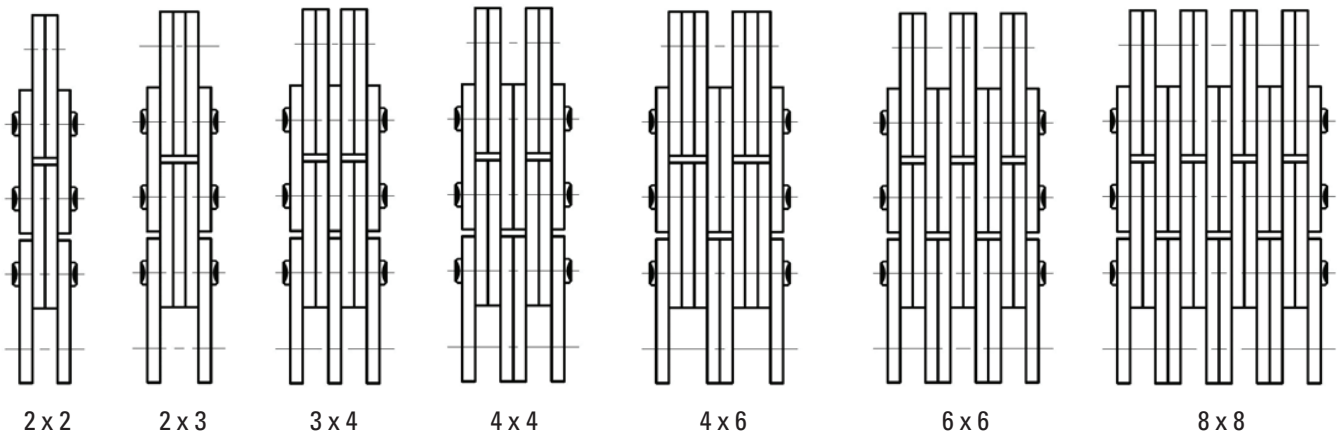

Dimensions: inch

Chain No.	Lacing	Pitch P	Pin Dia. D	Plate		Overall Width		Avg. Ult. Tensile Strength (Lbs.)	Avg. Weight Per Foot (Lbs.)
				Height H	Thickness T	F	G		
BL422	2 x 2	0.500	0.200	0.475	0.079	0.212	0.298	6,283	0.390
BL423	2 x 3					0.253	0.341	6,283	0.484
BL434	3 x 4					0.326	0.435	9,370	0.672
BL444	4 x 4					0.366	0.476	12,566	0.759
BL446	4 x 6					0.459	0.547	12,566	0.954
BL466	6 x 6					0.535	0.652	18,739	1.136
BL522	2 x 2	0.625	0.235	0.594	0.094	0.253	0.351	9,039	0.585
BL523	2 x 3					0.298	0.398	9,039	0.712
BL534	3 x 4					0.398	0.495	13,889	1.001
BL544	4 x 4					0.440	0.542	18,078	1.136
BL546	4 x 6					0.534	0.637	18,078	1.411
BL566	6 x 6					0.632	0.732	27,117	1.693
BL588	8 x 8					0.825	0.927	36,156	2.271
BL622	2 x 2					0.750	0.313	0.713	0.126
BL623	2 x 3	0.393	0.546	14,661	1.189				
BL634	3 x 4	0.524	0.685	22,046	1.646				
BL644	4 x 4	0.589	0.750	29,321	1.875				
BL646	4 x 6	0.719	0.880	29,321	2.332				
BL666	6 x 6	0.847	1.015	44,092	2.789				
BL688	8 x 8	1.116	1.278	58,423	3.951				

LEAF CHAIN

BL SERIES

[CONTINUED]

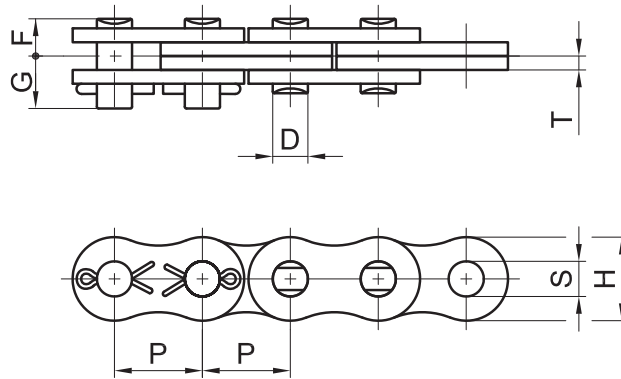

Dimensions: inch

Chain No.	Lacing	Pitch P	Pin Dia. D	Plate		Overall Width		Avg. Ult. Tensile Strength (Lbs.)	Avg. Weight Per Foot (Lbs.)
				Height H	Thickness T	F	G		
BL822	2 x 2	1.000	0.376	0.950	0.157	0.411	0.555	24,912	1.546
BL823	2 x 3					0.496	0.631	24,912	1.922
BL834	3 x 4					0.651	0.805	37,479	2.661
BL844	4 x 4					0.742	0.864	49,824	3.037
BL846	4 x 6					0.899	1.041	49,824	3.770
BL866	6 x 6					1.059	1.212	74,737	4.516
BL888	8 x 8					1.385	1.539	99,648	6.323
BL1022	2 x 2	1.250	0.437	1.188	0.189	0.505	0.665	34,172	2.459
BL1023	2 x 3					0.598	0.759	34,172	3.051
BL1034	3 x 4					0.787	0.948	51,257	4.233
BL1044	4 x 4					0.879	1.041	68,343	4.825
BL1046	4 x 6					1.068	1.230	68,343	6.007
BL1066	6 x 6					1.255	1.448	102,515	7.183
BL1088	8 x 8					1.639	1.823	132,277	9.542
BL1222	2 x 2	1.500	0.500	1.425	0.220	0.572	0.780	42,990	3.380
BL1223	2 x 3					0.682	0.786	42,990	4.200
BL1234	3 x 4					0.902	1.115	64,485	5.839
BL1244	4 x 4					1.015	1.223	85,980	6.659
BL1246	4 x 6					1.235	1.444	85,980	8.292
BL1266	6 x 6					1.467	1.652	128,970	9.932
BL1288	8 x 8					1.920	2.081	171,961	12.499
BL1422	2 x 2	1.750	0.563	1.663	0.252	0.642	0.850	49,824	4.543
BL1423	2 x 3					0.766	0.975	49,824	5.645
BL1434	3 x 4					1.024	1.233	74,737	7.862
BL1444	4 x 4					1.152	1.361	99,649	8.971
BL 1446	4 x 6					1.418	1.587	99,649	11.168
BL1466	6 x 6					1.674	1.843	149,473	13.386
BL1488	8 x 8					2.189	2.378	199,298	17.794
BL1622	2 x 2	2.000	0.687	1.900	0.280	0.724	0.948	78,264	5.544
BL1623	2 x 3					0.870	1.094	78,264	6.854
BL1634	3 x 4					1.159	1.376	117,396	8.991
BL1644	4 x 4					1.303	1.519	159,528	10.342
BL1646	4 x 6					1.588	1.805	159,528	12.794
BL1666	6 x 6					1.874	2.090	234,792	15.858
BL1688	8 x 8					2.444	2.553	313,056	21.053
BL2034	2 x 4	2.500	0.937	2.375	0.374	1.608	1.746	196,873	18.614
BL2044	4 x 4					1.803	1.941	262,571	21.234
BL2046	4 x 6					2.195	2.333	262,571	26.543
BL2066	6 x 6					2.587	2.724	393,746	31.851
BL2088	8 x 8					3.370	3.508	525,141	42.468

ANSI/ASME
STANDARD

ANSI/ASME
HEAVY

DOUBLE
PITCH

ISO
BRITISH

CORROSION
RESISTANT

SELF
LUBE

ATTACHMENT
CHAIN

SPECIALTY
CHAIN

LEAF
CHAIN

CONNECTING COMPONENTS

Looking for methods to anchor your leaf chain?

PEER Chain offers a variety of leaf chain clevis and anchors per customer specifications.

Contact PEER Chain for specific application needs.

Clevis Anchors

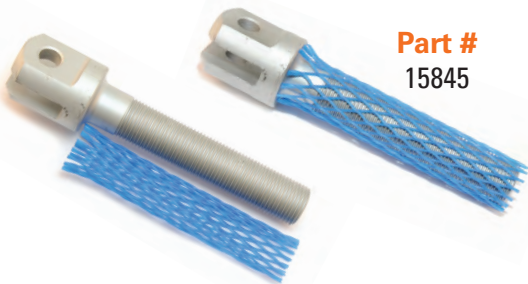

Part #
15845

Clevis Pin



Part #
42223

Anchor Blocks



Part #
6147



Part #
6143



Part #
6151



Door #2
Chepstow Castle - Wales



Door #3
Chrysler Building - NYC

Personal Notes

Your Name _____

Door #1
10 Downing Street - London

Dear Distributor – place your business card or info sticker here so your customers will know who to thank and call to place their orders.

TECH CENTER



Wear Life Test



Fatigue Test



Salt Spray Test



Door #4
Robie House - Chicago



Door #5
Palais Royal - Fes Morocco

Why We Say,
"Quality Links That Last!"

Four Generations of Performance, People and Passion Keep You Running!

Door #6
Palmer House - Chicago



Door #7
St. Edwards - Gloucestershire



Door #8
Ueno Toshogu Shrine - Tokyo



Door #9
U.S. Capitol - Washington, DC



Toll Free: +1.800.523.4567
 Phone: +1.847.775.4600
 Fax: +1.847.775.4650
 www.peerchain.com
 customerservice@peerchain.com