

engineering
catalog

volume
12

MOLINE
BEARING CO. U.S.A.

quality mounted bearings

MOLINE BEARING CO.

ACCESSIBLE RESPONSIVE FLEXIBLE KNOWLEDGEABLE QUALITY PROVEN HUMAN

WE WORK, EVERYDAY



WE ARE UP EARLY, WAKE THE KIDS, GRAB A CUP OF COFFEE AND HEAD OUT THE DOOR.

THE SUN RISING OVER FIELDS COVERED WITH MORNING DEW, GREETES US ALMOST DAILY AND EVERY DAY WE ARE REMINDED THAT THIS COUNTRY HAS BEEN GOOD TO US. AMERICA HAS REWARDED US WITH THE BUSINESS WE HAVE BUILT AND THE RELATIONSHIPS MADE ALONG THE WAY.

THIS LAND HAS GIFTED US OUR TRADE, A TRADE THAT HAS US STRIVING TO ALWAYS DO BETTER WHILE UNDERSTANDING THAT OUR HANDS CRAFT, BUILD AND SHIP QUALITY BEARINGS TO YOU.

FUNDAMENTALLY WE HAVE ONE JOB TO PERFORM; TO KEEP YOUR EQUIPMENT RUNNING SO THAT YOU CAN STAY IN OPERATION, PRODUCTIVE AND PROFITABLE.

CONSIDER THIS OUR OBLIGATION, TO SUPPLY THE MECHANICAL POWER INDUSTRY, QUALITY BEARINGS AND EXEMPLARY SERVICE.

THESE GOALS ARE WHAT GETS US UP, CRAFTING THE BEARINGS WE OFFER, EACH ONE..... DAILY.

DAVID FAUNTLEROY MOLINE BEARING CO.

BEARING C°

CONTENTS

TYPE E TAPERED ROLLER BEARINGS	9
Features	13
Type E 2-Bolt Pillow Block	14
Type E 4-Bolt Pillow Block	16
Type E 4-Bolt Flange	20
Type E Piloted Flange	24
Type E Wide Slot Take-up	26
Split E1000 Features	29
Split E1000 2-Bolt Pillow Block	30
Split E1000 4-Bolt Pillow Block	34
Split E1000 Cartridge Assembly	38
Type E Application Guide	40
Split E1000 Mounting Guide	45
Type E Radial Load Ratings	48
Type E Interchange	52
M2000 SPHERICAL ROLLER BEARINGS	55
Features	59
M2000 2-Bolt Pillow Block	60
M2000 4-Bolt Pillow Block	64
M2000 4-Bolt Flange	68
M2000 Piloted Flange Cartridge	70
M2000 Wide Slot Take-up	74
M2000 Application Guide	78
M2000 Radial Load Ratings	82
M2000 Interchange	84
ME2000 SPHERICAL ROLLER BEARINGS WITH TYPE E DIMENSIONS	87
Features	89
ME2000 2-Bolt Pillow Block	90
ME2000 4-Bolt Flange	92
ME2000 Piloted Flange Cartridge	94
ME2000 Application Guide	96
ME2000 Radial Load Ratings	100
ME2000 Interchange	102

CONTENTS

M3000 EVEN-LOK™ SPHERICAL ROLLER BEARINGS	105
Features	109
M3000 Even-Lok™ 2-Bolt Pillow Block	110
M3000 Even-Lok™ 4-Bolt Pillow Block	112
M3000 Even-Lok™ 4-Bolt Flange	114
M3000 Even-Lok™ Piloted Flange Cartridge	116
M3000 Even-Lok™ Wide Slot Take-up	118
M3000 Even-Lok™ Application Guide	120
M3000 Even-Lok™ Radial Load Ratings	124
M3000 Even-Lok™ Interchange	125
ME3000 EVEN-LOK™ SPHERICAL ROLLER BEARINGS WITH TYPE E DIMENSIONS	127
Features	129
ME3000 Even-Lok™ 2-Bolt Pillow Block	130
ME3000 Even-Lok™ 4-Bolt Flange	132
ME3000 Even-Lok™ Piloted Flange Cartridge	134
ME3000 Even-Lok™ Application Guide	136
ME3000 Even-Lok™ Radial Load Ratings	140
ME3000 Even-Lok™ Interchange	141
SPECIALTY ACCESSORIES AND SERVICES	143
Machining and Engineering	146
Coatings and Finishes	150
Bearing End Caps and Bearing Covers	152
Lubrications	154
Grease Tag Private Label Branding	156
MOUNTED BALL BEARINGS	159
Features	161
Mounted Ball Bearing Normal Duty Set Screw Lock 2-Bolt Pillow Block – UCP 200 Series	162
Mounted Ball Bearing Normal Duty Set Screw Lock 2-Bolt Flange – UCFL 200 Series	166
Mounted Ball Bearing Normal Duty Set Screw Lock 4-Bolt Flange – UCF 200 Series	170
Mounted Ball Bearing Normal Duty Set Screw Lock Piloted Flange – UCFC 200 Series	174
Mounted Ball Bearing Normal Duty Set Screw Lock Wide Slot Take-up – UCT 200 Series	178
Mounted Ball Bearing Normal Duty Set Screw Lock Insert – UC 200 Series	182
Mounted Ball Bearing Normal Duty Eccentric Locking 2-Bolt Pillow Block – HCP 200 Series	184
Mounted Ball Bearing Normal Duty Eccentric Locking 2-Bolt Flange – HCFL 200 Series	188
Mounted Ball Bearing Normal Duty Eccentric Locking 4-Bolt Flange – HCF 200 Series	192
Mounted Ball Bearing Normal Duty Eccentric Locking Piloted Flange – HCFC 200 Series	196
Mounted Ball Bearing Normal Duty Eccentric Locking Wide Slot Take-up – HCT 200 Series	200
Mounted Ball Bearing Normal Duty Eccentric Locking Insert – HC 200 Series	204

CONTENTS

Mounted Ball Bearing Medium Duty Set Screw Lock 2-Bolt Pillow Block – UCPX 200 Series	206
Mounted Ball Bearing Medium Duty Set Screw Lock 2-Bolt Flange – UCFLX 200 Series	210
Mounted Ball Bearing Medium Duty Set Screw Lock 4-Bolt Flange – UCFX 200 Series	212
Mounted Ball Bearing Medium Duty Set Screw Lock Piloted Flange – UCFCX 200 Series	216
Mounted Ball Bearing Medium Duty Set Screw Lock Insert – UCX 200 Series	220
Mounted Ball Bearing Application Guide	222
Mounted Ball Bearing Radial Load Ratings	224
Mounted Ball Bearing Interchange	228
SHAFT COLLARS	231
Solid Zinc Plated and Stainless Steel Shaft Collars	232
Black Oxide Single/Double Split Shaft Collars	234
Stainless Steel Single/Double Split Shaft Collars	236
NOMENCLATURE AND MASTER INTERCHANGE	239
Nomenclature	240
Master Interchange	242
Terms and Conditions of Sale	248



TYPE E
TAPERED
ROLLER
BEARINGS

Moline Type E Tapered Roller Bearings offer many advantages including high-speed suitability, positive locking to the shaft, ruggedness, and low price.

The housings are as compact as possible without sacrificing their brawny ruggedness. Made in the USA of high quality Class 30 cast iron, they are precision machined to close tolerances.

On each end of the inner race there is a Drive Collar with two headless set screws. These screws extend through clearance holes in the inner race, locking it to the shaft.

Moline uses only genuine Timken® Tapered Roller Bearings. They are made from vacuum degassed steel which gives rollers and races added life, and provides superior load and speed characteristics. A long inner race insures load distribution over a considerable length of shaft. In addition, the arrangements of Timken rollers and races is such that Moline Type E Mounted Bearings will handle slight angular shaft misalignment. These bearings also have high radial and thrust load capacities, and are capable of handling most combinations of loads found in all normal applications.

Moline Type E Pillow Blocks, Flange Bearings, Piloted Flange Bearings, and Wide Slot Take-ups are ready to slip onto the shaft when received, because they are completely assembled, adjusted, sealed and pre-lubricated at the factory. There is no danger of bearing failure resulting from dirt or dust entering the bearing before or during installation.

Such contamination is very difficult to prevent in bearings that are not shaft ready. No time or expense is required for cleaning housings, for adjusting, or for initial lubrication. Therefore, overall installed cost is less in many instances. Operating expense over time is also generally less.

The V-Guard™ contact seal, which is built in at each end of the bearing during factory assembly, effectively seals against loss of lubricant and admission of dust and dirt, both on and off the shaft. Efficiency of the seal is consistent throughout the allowable range of self-alignment.

Bore tolerance is $+.001"/- .000"$ for 3" and smaller bores; $+.002"/- .000"$ for bores larger than 3".

Moline Mounted Type E bearings are available in shaft sizes from 1" to 7" and 25 to 180mm in Pillow Blocks, $1\frac{3}{16}"$ to $4\frac{1}{2}"$ and 35 to 115mm in 4-Bolt Flanges, $1\frac{1}{2}"$ to 5" and 40 to 125mm in Piloted Flanges, and $1\frac{3}{4}"$ to $3\frac{1}{2}"$ and 45 to 90mm in Wide Slot Take-ups.

All housings are available in our standard painted finish. Custom Colors, Powder Coating, Stainless Steel Powder coating, Nickel plating, Epoxy coatings and Teflon coatings will be quoted on request.

Moline Type E bearings are carried in warehouse and distributor stocks all over the United States and in Canada.

TYPE E

V-Guard™ Contact Seal for dirt and wet environments

Set screws in collars lock inner race to shaft

Timken DEE Tapered Roller Bearing Insert

Elongated bolt holes permit adjustment and increased mounting options

Long inner race locked to shaft on both ends

Rugged outer housing
Made in the USA

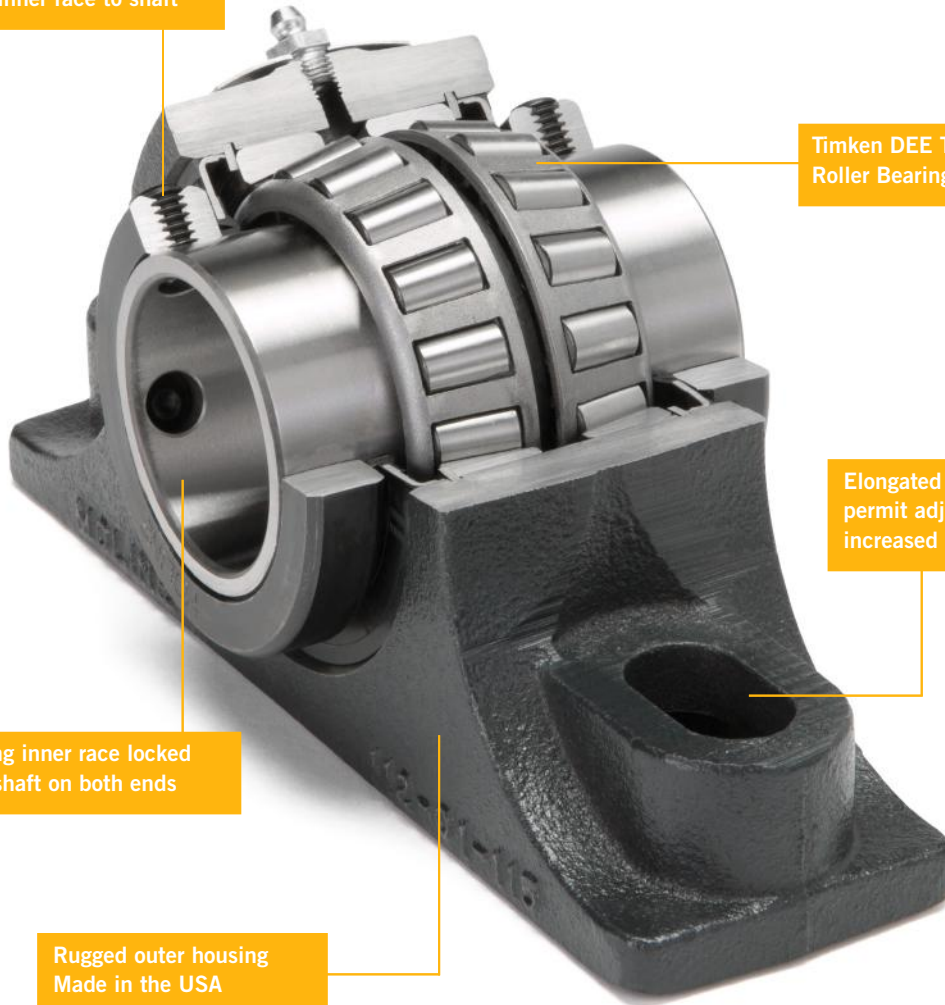

MOLINE TYPE E MOUNTED BEARINGS

TIMKEN® TIMKEN INSERT INSIDE



FEATURES OF MOLINE TYPE E TAPERED ROLLER BEARINGS

WITH TIMKEN® TAPERED ROLLER BEARINGS

- For applications that have high radial, thrust loads, or combination of both with minimal misalignment needs
- Dimensionally interchangeable with comparable Type E units, Moline Split E1000, Moline ME2000 and ME3000
- Suggested Industry Applications: Conveying, Screening, Cranes, Mining, Forestry, Oil, Gas, Power Generation, Aggregate
- Available in shaft sizes from 1" to 7", and 35mm to 180mm
- Assembled, adjusted and pre-lubricated in advance for immediate use
- All components are made, machined and assembled in the USA
- Built with Timken™ Enhanced DEE tapered roller bearings with the highest industry load ratings, double-extended inner race, case hardened rollers and races
- Extended inner race has two locking collars with 65° set screw spacing
- Misalignment = .010" per foot of shaft
- Close fit oversized collars act as flingers for additional protection in dusty or damp environments
- Standard V-Guard™ Nitrile and Teflon Contact Seal or Balanced Labyrinth Seal
- Timken™ Lithium Complex Grease operating temperature is up to 250°, High temperature grease is available up to 350°
- For custom lubrication, please see page 154 or contact the factory for more information
- Housings of Class 30 cast iron are made in Illinois, Iowa and Wisconsin
- Housings available in the standard painted finish. Powder coating in RAL or custom colors, Stainless Steel Powder coating, Nickel-plating, Epoxy, Teflon and other coatings are available. See page 150 or contact the factory for further information
- Custom machining and design service are available. See page 146 or contact the factory for further information
- Made in the United States

Standard V-Guard™ Contact Seal made of Nitrile, Teflon and Steel for extreme dirt and wet environments



Balanced Metal Labyrinth Seal for high speed and high temp applications



TYPE E 2-BOLT PILLOW BLOCK

TYPE E

SHAFT SIZE	MOLINE PART #	DIMENSIONS (INCHES)											WEIGHT LBS.		
		A	B	C	MIN D	CENTER TO CENTER D	MAX D	F	G*	H	J	L		M	
1	19321100	2 ⁷ / ₈										2			
1 ³ / ₁₆	19321103	2 ³ / ₄	6 ¹ / ₄	1 ⁷ / ₈	4 ³ / ₁₆	4 ⁹ / ₁₆	5	1/2	1	7/8	3	2 ¹ / ₄	1 ¹ / ₂	4	
1 ¹ / ₄	19321104											2			
25 mm	19321025											2 ⁷ / ₈			
1 ³ / ₈	19321106	3	7 ³ / ₈	2 ¹ / ₈	5	5 ¹ / ₂	6	1/2	1 ¹ / ₈	1 ¹ / ₈	3 ⁷ / ₈	2 ¹ / ₂	1 ⁷ / ₈	6.9	
1 ⁷ / ₁₆	19321107														
35 mm	19321035														
1 ¹ / ₂	19321108	3 ³ / ₈	7 ⁷ / ₈	2 ³ / ₈	5 ⁵ / ₈	6 ¹ / ₁₆	6 ¹ / ₂	1/2	1 ¹ / ₁₆	1 ¹ / ₄	4 ¹ / ₄	2 ⁷ / ₈	2 ¹ / ₈	9.5	
1 ⁵ / ₈	19321110														
1 ¹¹ / ₁₆	19321111														
40 mm	19321040														
1 ³ / ₄	19321112	3 ¹ / ₂	8 ⁷ / ₈	2 ¹ / ₂	6 ¹ / ₈	6 ¹¹ / ₁₆	7 ¹ / ₄	5/8	1 ⁵ / ₁₆	1 ⁵ / ₁₆	4 ¹ / ₂	3 ³ / ₈	2 ¹ / ₄	11	
1 ⁷ / ₈	19321114														
1 ¹⁵ / ₁₆	19321115														
2	19321200														
45 mm	19321045														
50 mm	19321050														
2 ³ / ₁₆	19321203	3 ³ / ₄	9 ⁵ / ₈	2 ⁵ / ₈	6 ¹¹ / ₁₆	7 ³ / ₈	8	5/8	1 ⁷ / ₁₆	1 ¹ / ₂	5	3 ⁵ / ₈	2 ¹ / ₂	14	
55 mm	19321055														
2 ¹ / ₄	19321204	4	10 ¹ / ₂	2 ⁷ / ₈	7 ¹ / ₈	7 ⁷ / ₈	8 ⁵ / ₈	5/8	1 ¹ / ₂	1 ⁵ / ₈	5 ¹ / ₁₆	4	2 ³ / ₄	19	
2 ⁷ / ₁₆	19321207														
2 ¹ / ₂	19321208														
60 mm	19321060														
65 mm	19321065														
2 ¹ / ₁₆	19321211	4 ¹ / ₂	12	3	7 ⁷ / ₈	8 ¹³ / ₁₆	9 ³ / ₄	3/4	1 ¹³ / ₁₆	1 ⁷ / ₈	6 ⁵ / ₁₆	4 ¹¹ / ₁₆	3 ¹ / ₈	26	
2 ³ / ₄	19321212														
2 ¹⁵ / ₁₆	19321215														
3	19321300														
70 mm	19321070														
75 mm	19321075														
3 ³ / ₁₆	19321303	5	14	3 ⁵ / ₈	9 ³ / ₄	10 ⁵ / ₈	11 ¹ / ₂	7/8	1 ⁷ / ₈	2 ¹ / ₄	7 ¹ / ₂	5 ⁵ / ₁₆	3 ³ / ₄	44	
3 ¹ / ₄	19321304														
3 ⁷ / ₁₆	19321307														
3 ¹ / ₂	19321308														
80 mm	19321080														
85 mm	19321085														
90 mm	19321090														

*Note: The elongated slots give broader mounting capabilities.



TYPE E 2-BOLT PILLOW BLOCK

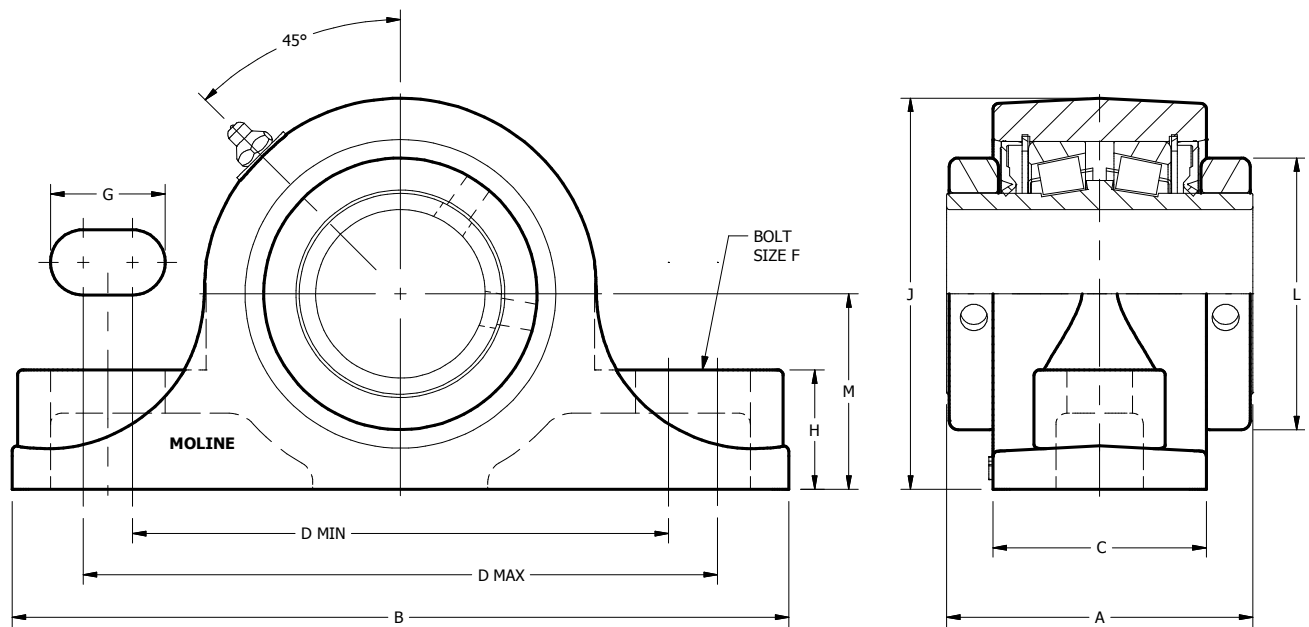

TYPE E



TYPE E 4-BOLT PILLOW BLOCK

TYPE E

SHAFT SIZE	MOLINE PART #	DIMENSIONS (INCHES)													WEIGHT LBS.
		A	B	C	MIN D	CENTER TO CENTER D	MAX D	E	F	G*	H	J	L	M	
2 1/4	19341204	4	10 1/2	3 1/2	8 5/16	8 1/2	8 11/16	1 7/8	5/8	7/8	1 5/8	5 1/2	4	2 3/4	19
2 7/16	19341207														
2 1/2	19341208														
60mm	19341060														
65mm	19341065														
2 11/16	19341211	4 1/2	12	4	9 3/16	9 1/2	9 13/16	2 1/8	5/8	7/8	1 7/8	6 1/4	4 11/16	3 1/8	26
2 3/4	19341212														
2 15/16	19341215														
3	19341300														
70mm	19341070														
75mm	19341075														
3 3/16	19341303	5	14	4 1/2	10 3/4	11	11 1/4	2 3/8	3/4	1 3/16	2 1/4	7 1/2	5 5/16	3 3/4	44
3 1/4	19341304														
3 7/16	19341307														
3 1/2	19341308														
80mm	19341080														
85mm	19341085														
90mm	19341090														
3 15/16	19341315	6 1/4	15 1/4	4 1/2	10 7/16	11 11/16	12 7/8	2 1/4	3/4	1 1/8	2 7/16	8 1/2	5 3/4	4 1/4	65
4	19341400														
100mm	19341100														

*Note: The elongated slots give broader mounting capabilities.



TYPE E 4-BOLT PILLOW BLOCK

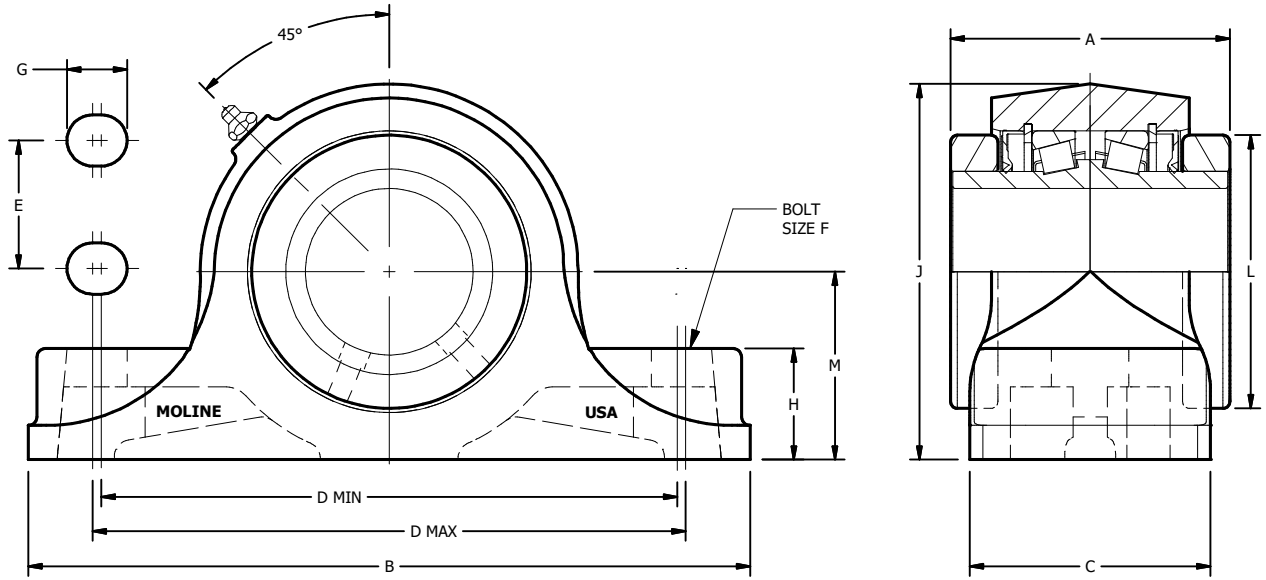

TYPE E



TYPE E 4-BOLT PILLOW BLOCK CONTINUED

TYPE E

SHAFT SIZE	MOLINE PART #	DIMENSIONS (INCHES)													WEIGHT LBS.
		A	B	C	MIN D	CENTER TO CENTER D	MAX D	E	F	G*	H	J	L	M	
4 ⁷ / ₁₆	19341407	6 ³ / ₄	16 ⁵ / ₈	4 ⁵ / ₈	13 ¹ / ₄	13 ¹ / ₂	13 ³ / ₄	2 ¹ / ₂	3/4	1 ³ / ₁₆	2 ³ / ₄	9 ³ / ₈	6 ¹ / ₄	4 ³ / ₄	81
4 ¹ / ₂	19341408														
110mm	19341110														
115mm	19341115														
4 ¹⁵ / ₁₆	19341415	7 ¹ / ₄	18 ¹ / ₂	5 ¹ / ₈	15	15 ¹ / ₂	16	2 ³ / ₄	7/8	1 ¹ / ₄	3	10 ⁷ / ₈	7 ¹ / ₄	5 ¹ / ₂	132
5	19341500														
125mm	19341125														
5 ⁷ / ₁₆	19341507	9	22	6 ¹ / ₄	17 ³ / ₈	18 ¹ / ₄	19 ¹ / ₈	3 ³ / ₄	1	2	3 ¹ / ₄	13 ³ / ₁₆	9 ³ / ₈	6 ¹¹ / ₁₆	243
5 ¹ / ₂	19341508														
5 ¹⁵ / ₁₆	19341515														
6	19341600														
130mm	19341130														
135mm	19341135														
140mm	19341140														
150mm	19341150														
6 ⁷ / ₁₆	19341607	10 ¹ / ₂	26	7 ⁷ / ₈	21 ¹ / ₄	22 ¹ / ₄	23 ¹ / ₄	4 ⁵ / ₈	1	2 ¹ / ₈	3 ¹ / ₁₆	15	10 ¹ / ₂	7 ¹ / ₂	356
6 ¹ / ₂	19341608														350
6 ¹⁵ / ₁₆	19341615														340
7	19341700														335
160mm	19341160														340
170mm	19341170														340
180mm	19341180														335

*Note: The elongated slots give broader mounting capabilities.



TYPE E 4-BOLT PILLOW BLOCK

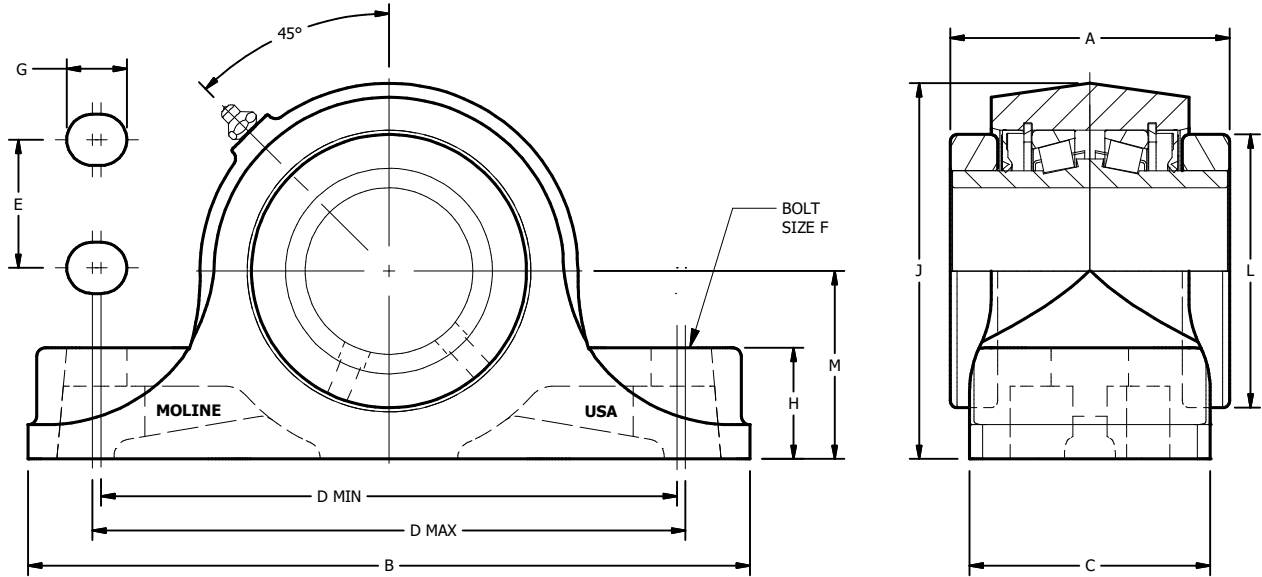

TYPE E



For personal service 800.242.4633
 CAD drawings at no additional charge
 For nomenclature see pages 240 and 241

MOLINE BEARING CO



TYPE E 4-BOLT FLANGE

SHAFT SIZE	MOLINE PART #	DIMENSIONS (INCHES)									WEIGHT LBS.
		A	B	C	D	E	F	H	J	L	
1 3/16 1 1/4	19311103 19311104	2 3/4	3 3/4	2 11/32	2 7/8	1/16	3/8	1	2 15/16	2 1/4	4.5
1 3/8 1 7/16 35mm	19311106 19311107 19311035	3	4 5/8	2 19/32	3 1/2	1/16	1/2	1 1/16	3 7/8	2 3/4	6.7
1 1/2 1 5/8 1 11/16 40mm	19311108 19311110 19311111 19311040	3 3/8	5 3/8	2 31/32	4 1/8	1/8	1/2	1 3/16	4 1/4	3 1/8	10
1 3/4 1 7/8 1 15/16 2 45mm 50mm	19311112 19311114 19311115 19311200 19311045 19311050	3 1/2	5 5/8	3 3/32	4 3/8	1/8	1/2	1 3/16	4 1/2	3 3/8	12
2 3/16 55mm	19311203 19311055	3 3/4	6 1/4	3 9/32	4 7/8	1/8	5/8	1 3/8	4 7/8	3 3/4	16
2 1/4 2 7/16 2 1/2 60mm 65mm	19311204 19311207 19311208 19311060 19311065	4	6 7/8	3 9/16	5 3/8	3/16	5/8	1 1/2	5 3/4	4	21

TYPE E



TYPE E 4-BOLT FLANGE

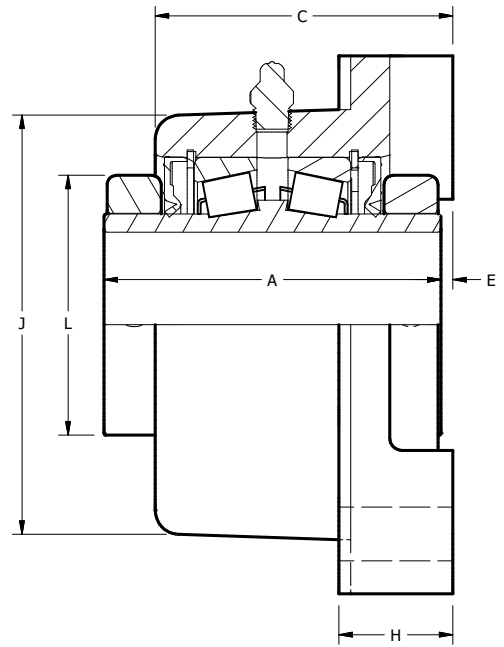
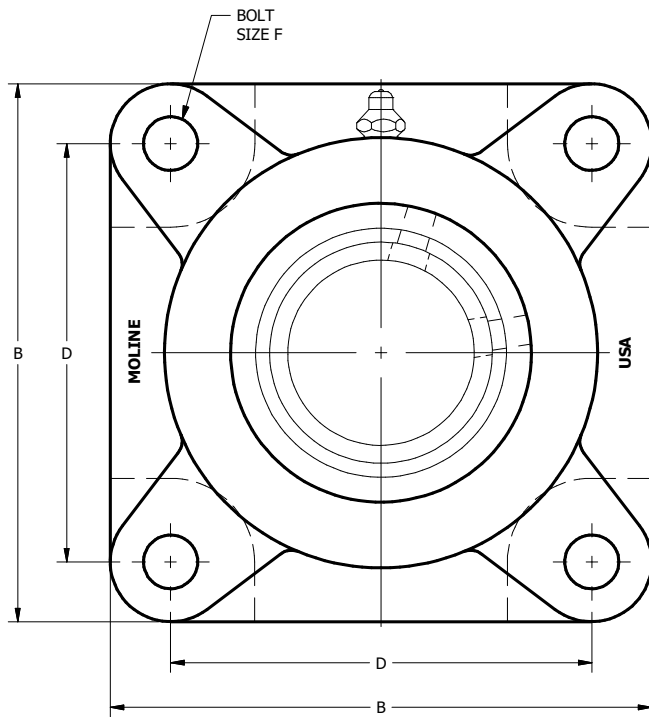

TYPE E



TYPE E 4-BOLT FLANGE CONTINUED

SHAFT SIZE	MOLINE PART #	DIMENSIONS (INCHES)									WEIGHT LBS.
		A	B	C	D	E	F	H	J	L	
2 1/16	19311211	4 1/2	7 3/4	3 15/16	6	3/16	3/4	1 5/8	6 1/2	4 11/16	28
2 3/4	19311212										
2 15/16	19311215										
3	19311300										
70mm	19311070										
75mm	19311075										
3 3/16	19311303	5	9 1/4	4 1/2	7	1/4	3/4	1 7/8	7 5/8	5 5/16	51
3 1/4	19311304										
3 7/16	19311307										
3 1/2	19311308										
80mm	19311080										
85mm	19311085										
90mm	19311090										
3 15/16	19311315	6 1/4	10 1/4	5 5/8	7 3/4	1/4	7/8	2 1/8	8 7/16	5 3/4	74
4	19311400										
100mm	19311100M										
4 7/16	19311407	6 3/4	10 7/8	5 15/16	8 3/4	1 1/32	7/8	2 7/16	9 1/8	6 1/4	96
4 1/2	19311408										
110mm	19311110M										
115mm	19311115M										

TYPE E



TYPE E 4-BOLT FLANGE

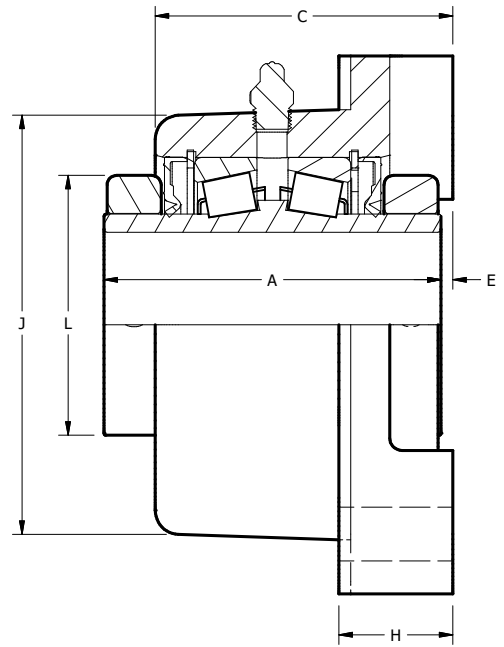
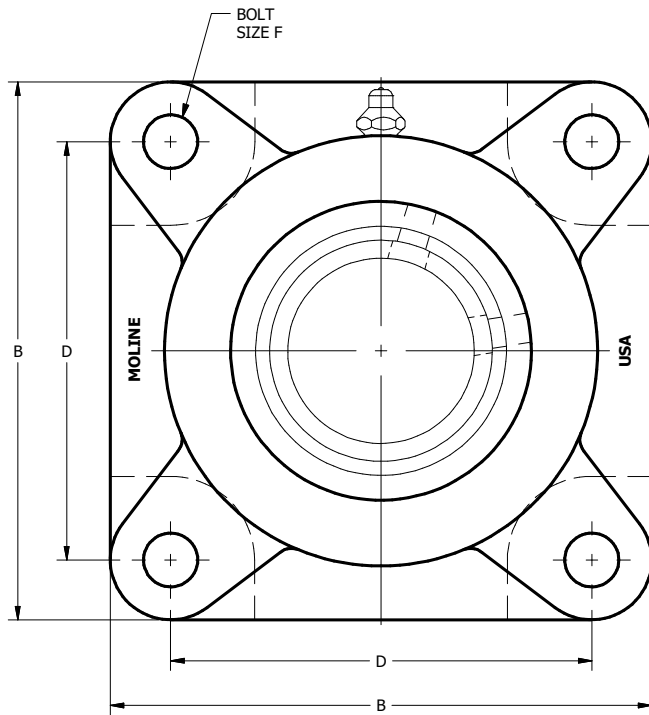

TYPE E



TYPE E PILOTED FLANGE

TYPE E

SHAFT SIZE	MOLINE PART #	DIMENSIONS (INCHES)												WEIGHT LBS.
		A	B	C	D	E	F	G	H	K	L	M	P	
1 1/2 1 5/8 1 11/16 40mm	19331108 19331110 19331111 19331040	3 3/8	6 1/8	2 13/16	5 1/8	1 3/8	7/16	1 9/16	7/16	4 1/4	3 1/8	3.62	1 1/16	9.2
1 3/4 1 7/8 1 15/16 2 45mm 50mm	19331112 19331114 19331115 19331200 19331045 19331050	3 1/2	6 3/8	2 29/32	5 3/8	1 3/16	7/16	1 9/16	9/16	4 1/2	3 3/8	3.80	1 1/32	10.3
2 3/16 55mm	19331203 19331055	3 3/4	7 1/8	3 3/32	6	1 3/16	1/2	1 11/16	9/16	5	3 3/4	4.24	1 3/32	12
2 1/4 2 7/16 2 1/2 60mm 65mm	19331204 19331207 19331208 19331060 19331065	4	7 5/8	3 5/16	6 1/2	1 5/16	1/2	1 13/16	5/8	5 1/2	4	4.60	1 1/4	16
2 11/16 2 3/4 2 15/16 3 70mm 75mm	19331211 19331212 19331215 19331300 19331070 19331075	4 1/2	8 3/4	3 11/16	7 1/2	1 1/2	5/8	2	3/4	6 3/8	4 11/16	5.30	1 1/4	28
3 3/16 3 1/4 3 7/16 3 1/2 80mm 85mm 90mm	19331303 19331304 19331307 19331308 19331080 19331085 19331090	5	10 1/4	4 3/16	8 5/8	1 1/4	3/4	2 7/16	7/8	7 3/8	5 5/16	6.10	1 21/32	43
3 15/16 4 100mm	19331315 19331400 19331100	6 1/4	10 7/8	4 1/2	9 3/8	1 1/2	3/4	2 11/16	15/16	8 1/8	5 3/4	6.63	1 7/8	57
4 7/16 4 1/2 110mm 115mm	19331407 19331408 19331110M 19331115M	6 3/4	13 1/2	4 5/8	11 3/4	1 1/2	3/4	3 1/32	1	10 1/4	6 1/4	5.09	2	93
4 15/16 5 125mm	19331415 19331500 19331125	7 1/4	14 3/4	5 1/16	12 3/4	1 3/4	7/8	2 31/32	1 1/4	11	7 1/4	5.52	1 7/8	122



TYPE E PILOTED FLANGE

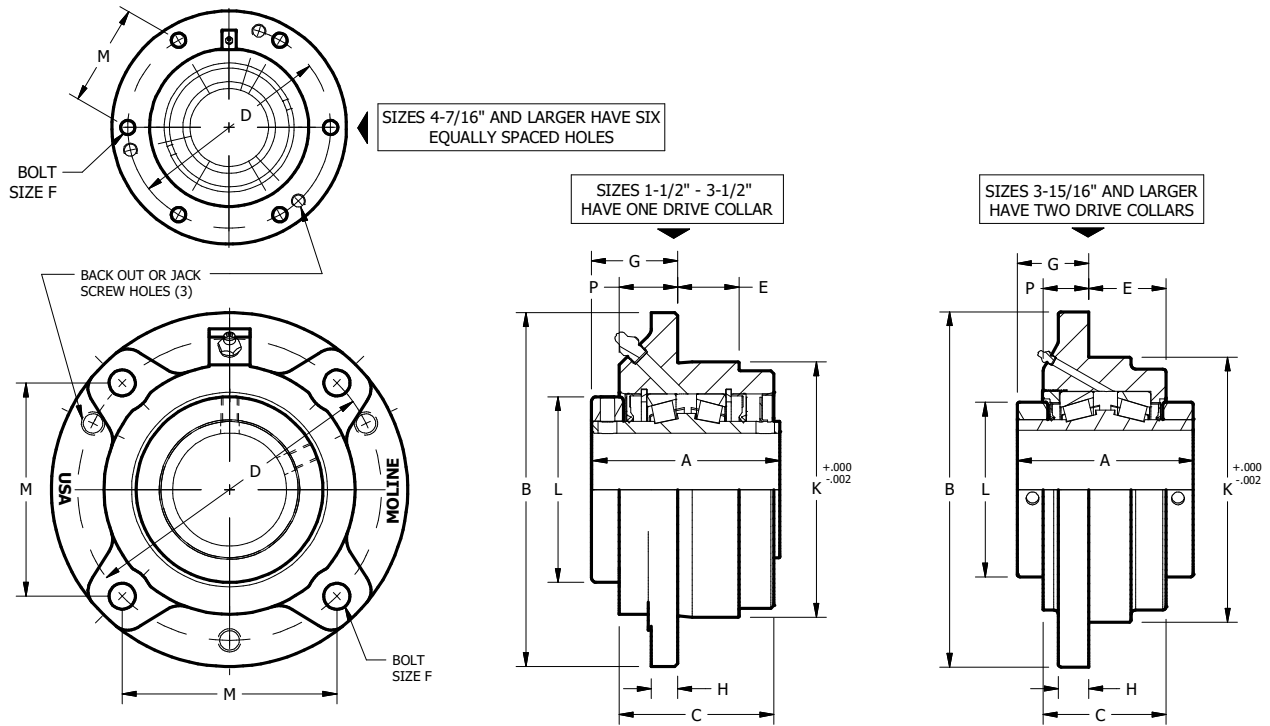

TYPE E



TYPE E WIDE SLOT TAKE-UP

SHAFT SIZE	MOLINE PART #	DIMENSIONS (INCHES)														WEIGHT LBS.	
		A	B	C	D	E	F	G	H	J	K	L	M	N	T		
1 3/4	19351112																
1 7/8	19351114																
1 15/16	19351115	3 1/2	6 5/16	1 1/16	3 3/4	3 15/16	1	1 5/16	3/4	3 5/16	1 15/16	3 3/8	4	4 3/4	2 7/16	12	
2	19351200																
45mm	19351045																
50mm	19351050																
2 3/16	19351203	3 3/4	7 1/8	1 3/16	3 3/4	4 5/8	1 1/8	1	1	3 7/8	2 1/4	3 3/4	4 1/2	5 1/4	2 9/16	16	
55mm	19351055																
2 1/4	19351204																
2 7/16	19351207																
2 1/2	19351208	4	7 13/16	1 1/32	4 1/2	5 1/16	1 1/2	1 1/16	1 1/4	4 1/4	2 1/2	4	5 1/8	6	2 3/4	21	
60mm	19351060																
65mm	19351065																
2 11/16	19351211	4 1/2	9 1/8	1 25/32	4 3/4	5 7/8	1 1/2	1 3/8	1 1/4	4 7/8	2 3/4	4 11/16	5 15/16	6 3/4	3	30	
2 3/4	19351212																
2 15/16	19351215																
3	19351300																
70mm	19351070																
75mm	19351075																
3 3/16	19351303	5	10 1/4	1 25/32	6	6 3/8	1 3/4	1 1/16	1 5/8	4 7/8	2 7/8	5 5/16	6 13/16	7 13/16	3 5/8	45	
3 1/4	19351304																
3 7/16	19351307																
3 1/2	19351308																
80mm	19351080																
85mm	19351085																
90mm	19351090																

TYPE E



TYPE E WIDE SLOT TAKE-UP

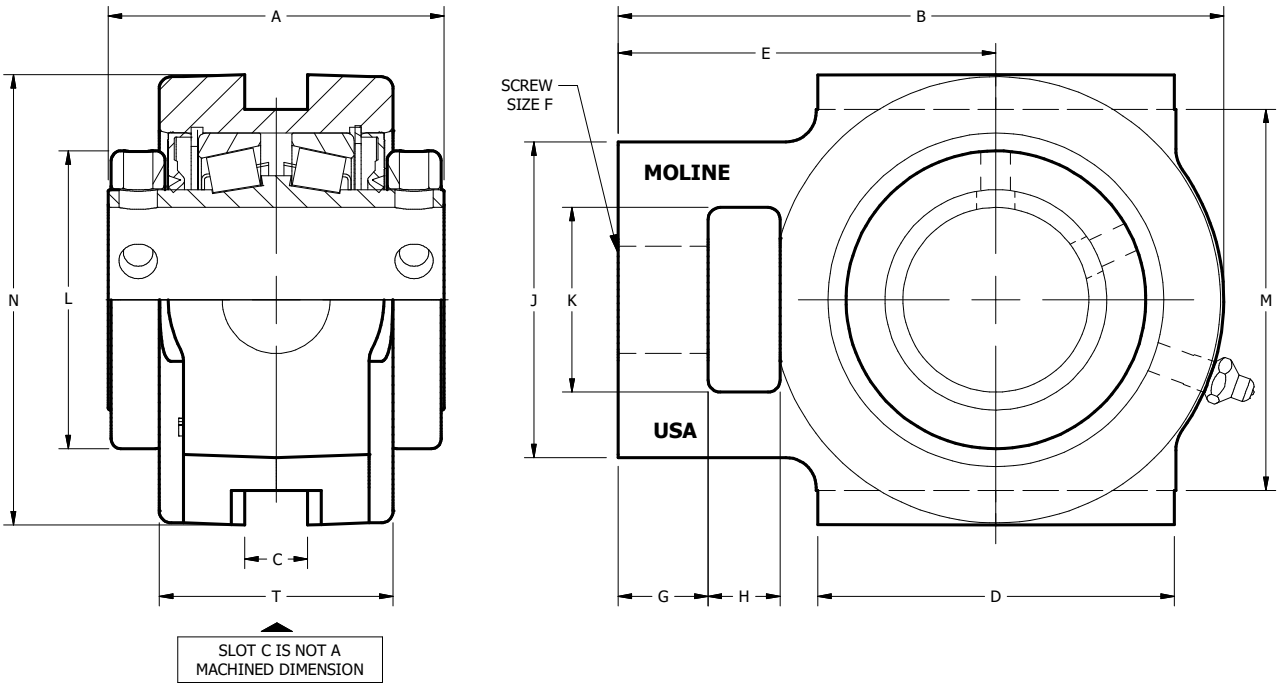

TYPE E



For personal service 800.242.4633
 CAD drawings at no additional charge
 For nomenclature see pages 240 and 241

MOLINE BEARING CO.



TYPE E



MOLINE SPLIT E1000 MOUNTED BEARINGS

TIMKEN® TIMKEN INSERT INSIDE



FEATURES OF MOLINE SPLIT E1000 SPHERICAL ROLLER BEARINGS

- For applications that have heavy radial and thrust load needs and require misalignment capability
- Dimensionally interchangeable with comparable Split E units, Moline Type E, ME2000 and ME3000
- Suggested Industry Applications: Mining, Aggregate & Cement, Paper & Forestry, Air Handling, Baggage Handling, and Food Processing
- Available in shaft sizes from 1 $\frac{3}{16}$ " to 5", and 35mm to 125mm
- Assembled, adjusted and pre-lubricated in advance for immediate use
- All components are made, machined and assembled in the USA
- Built with Timken™ Enhanced DEE tapered roller bearings with the highest industry load ratings, double-extended inner race, case hardened rollers and races
- Extended inner race has two locking collars with 65° set screw spacing
- +/-4° misalignment capacity
- Available in Expansion (red tag) and Non-Expansion (yellow tag) capabilities
- Replaceable solid cartridge assembly for easy maintenance
- Steel cartridge is Black Oxide coated for corrosion protection
- Standard V-Guard™ Contact Seal made of Nitrile, Teflon and Steel for extreme dirt and wet environments
- Timken™ Lithium Complex Grease operating temperature is up to 250°, High temperature grease is available up to 350°
- For custom lubrication, please see page 154 or contact the factory for more information
- Housings of high strength Class 65-45-12 Ductile Iron made in Illinois and Wisconsin
- Housings available in the standard painted finish. Powder coating in RAL or custom colors, Stainless Steel Powder coating, Nickel-plating, Epoxy, Teflon and other coatings are available. See page 150 or contact the factory for further information
- Custom machining and design service are available. See page 146 or contact the factory for further information
- Made in the United States

Standard V-Guard™ Contact Seal made of Nitrile, Teflon and Steel for extreme dirt and wet environments



Balanced Metal Labyrinth Seal for high speed and high temp applications



SPLIT E1000 2-BOLT PILLOW BLOCK

TYPE E

SHAFT SIZE	MOLINE PART #		DIMENSIONS (INCHES)					
	EXP	NON-EXP	A	B	C	D MIN	CTR TO CTR D	D MAX
1 3/16 1 1/4	39322103 39322104	49322103 49322104	2.75	6 1/4	1 7/8	4 9/16	4 3/4	4 15/16
1 3/8 1 7/16 35mm	39322106 39322107 39322035	49322106 49322107 49322035	3.00	7 1/4	2 3/16	5 5/16	5 5/8	5 15/16
1 1/2 1 5/8 1 11/16 40mm	39322108 39322110 39322111 39322040	49322108 49322110 49322111 49322040	3.38	7 3/4	2 3/8	5 9/16	6	6 7/16
1 3/4 1 7/8 1 15/16 2 45mm 50mm	39322112 39322114 39322115 39322200 39322045 39322050	49322112 49322114 49322115 49322200 49322045 49322050	3.50	8 7/8	2 1/2	6 5/16	6 3/4	7 1/4
2 3/16 55mm	39322203 39322055	49322203 49322055	3.75	9 5/8	2 5/8	6 11/16	7 5/16	7 15/16

*EXP is total expansion divided equally on both sides of the bearing (expansion bearing only).

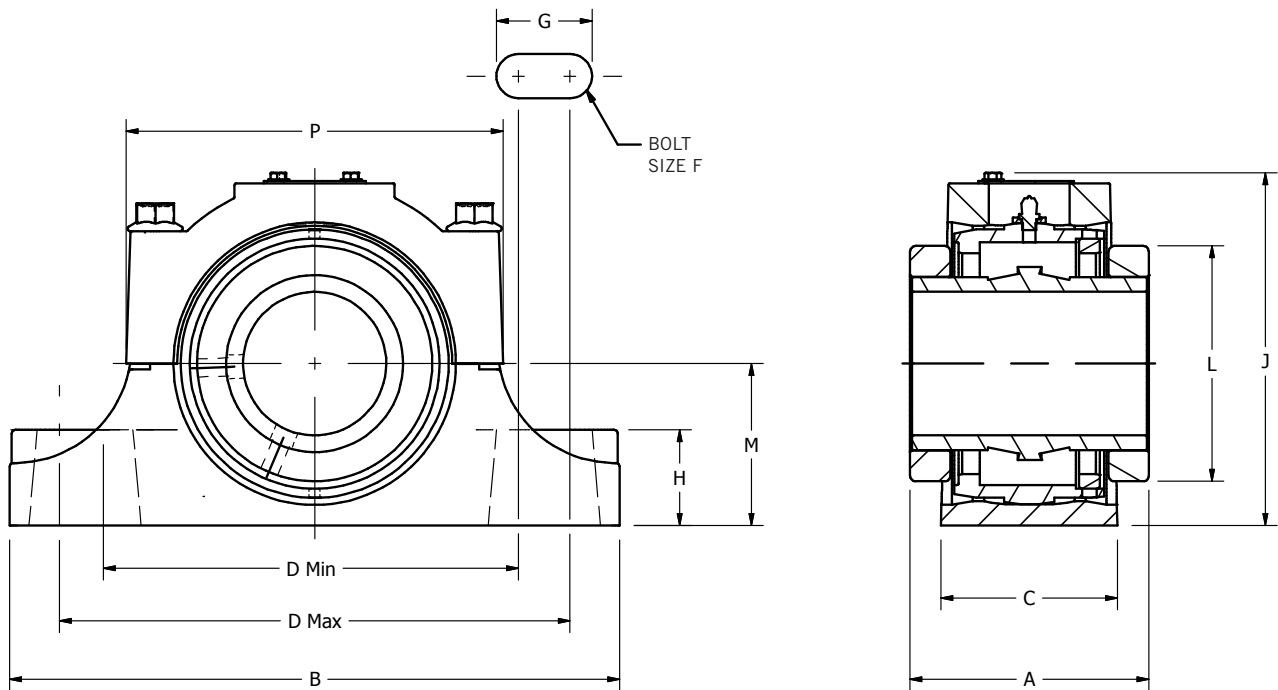

SPLIT E1000 PILLOW BLOCK TAPERED ROLLER BEARING

SHAFT SIZE	DIMENSIONS (INCHES)								WT. LBS.
	F	G	H	J	L	M	P	EXP*	
1 ³ / ₁₆ 1 ¹ / ₄	1/2	3/4	7/8	3 1/2	2 1/4	1.50	4 1/16	.56	9
1 ³ / ₈ 1 ⁷ / ₁₆ 35mm	1/2	15/16	1 1/8	4 3/16	2 1/2	1.88	4 5/8	.56	11
1 1/2 1 5/8 1 11/16 40mm	1/2	1 1/16	1 1/4	4 11/16	2 7/8	2.13	5 1/8	.56	14
1 3/4 1 7/8 1 15/16 2 45mm 50mm	5/8	1 3/16	1 5/16	5	3 1/8	2.25	5 13/16	.56	16
2 3/16 55mm	5/8	1 3/8	1 1/2	5 7/16	3 5/8	2.50	6	.56	19

TYPE E



For personal service 800.242.4633
 CAD drawings at no additional charge
 For nomenclature see pages 240 and 241

MOLINE BEARING CO



SPLIT E1000 2-BOLT PILLOW BLOCK

TYPE E

SHAFT SIZE	MOLINE PART #		DIMENSIONS (INCHES)					
	EXP	NON-EXP	A	B	C	D MIN	CTR TO CTR D	D MAX
2 ¼	39322204	49322204	4.00	10 ¾	3	6 15/16	7 13/16	8 11/16
2 7/16	39322207	49322207						
2 ½	39322208	49322208						
60mm	39322060	49322060						
65mm	39322065	49322065						
2 11/16	39322211	49322211	4.50	11 ¾	3 7/16	8 1/16	9	10
2 ¾	39322212	49322212						
2 15/16	39322215	49322215						
3	39322300	49322300						
70mm	39322070	49322070						
75mm	39322075	49322075						
3 3/16	39322303	49322303	5.00	13 ¾	4 1/16	10 ½	10 15/16	11 ¾
3 ¼	39322304	49322304						
3 7/16	39322307	49322307						
3 ½	39322308	49322308						
80mm	39322080	49322080						
85mm	39322085	49322085						
90mm	39322090	49322090						

*EXP is total expansion divided equally on both sides of the bearing (expansion bearing only).

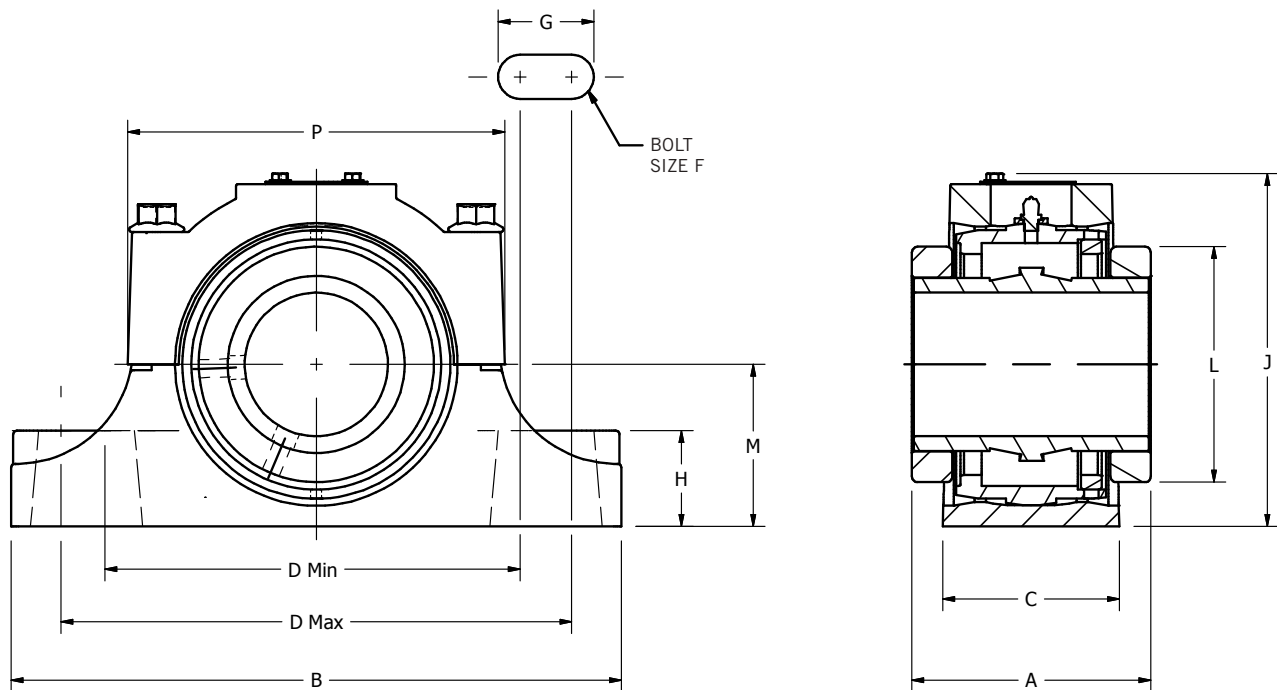

SPLIT E1000 PILLOW BLOCK TAPERED ROLLER BEARING

SHAFT SIZE	DIMENSIONS (INCHES)								WT. LBS.
	F	G	H	J	L	M	P	EXP*	
2 ¼ 2 7/16 2 ½ 60mm 65mm	5/8	1 5/8	1 5/8	6	4	2.75	6 7/16	.56	24
2 11/16 2 ¾ 2 15/16 3 70mm 75mm	¾	1 13/16	1 7/8	6 ¾	4 5/8	3.13	7 ½	.56	35
3 3/16 3 ¼ 3 7/16 3 ½ 80mm 85mm 90mm	7/8	1 13/16	2 ¼	7 15/16	5 5/16	3.75	9 3/8	.56	59

TYPE E



For personal service 800.242.4633
 CAD drawings at no additional charge
 For nomenclature see pages 240 and 241

MOLINE BEARING CO



SPLIT E1000 4-BOLT PILLOW BLOCK

TYPE E

SHAFT SIZE	MOLINE PART #		DIMENSIONS (INCHES)						
	EXP	NON-EXP	A	B	C	D MIN	CTR TO CTR D	D MAX	E
2 ¼	39342204	49342204	4.00	10 ¾	3 ½	7 ¾	8 ½	8 ¾	1 ⅞
2 ⅞	39342207	49342207							
2 ½	39342208	49342208							
60mm	39342060	49342060							
65mm	39342065	49342065							
2 11/16	39342211	49342211	4.50	11 ¾	3 ¾	8 ¾	9 ½	10	2 ⅞
2 ¾	39342212	49342212							
2 15/16	39342215	49342215							
3	39342300	49342300							
70mm	39342070	49342070							
75mm	39342075	49342075	5.00	13 ¾	4 ½	10 9/16	11	11 ¾	2 ¾
3 3/16	39342303	49342303							
3 ¼	39342304	49342304							
3 7/16	39342307	49342307							
3 ½	39342308	49342308							
80mm	39342080	49342080							
85mm	39342085	49342085							
90mm	39342090	49342090							

*EXP is total expansion divided equally on both sides of the bearing (expansion bearing only).

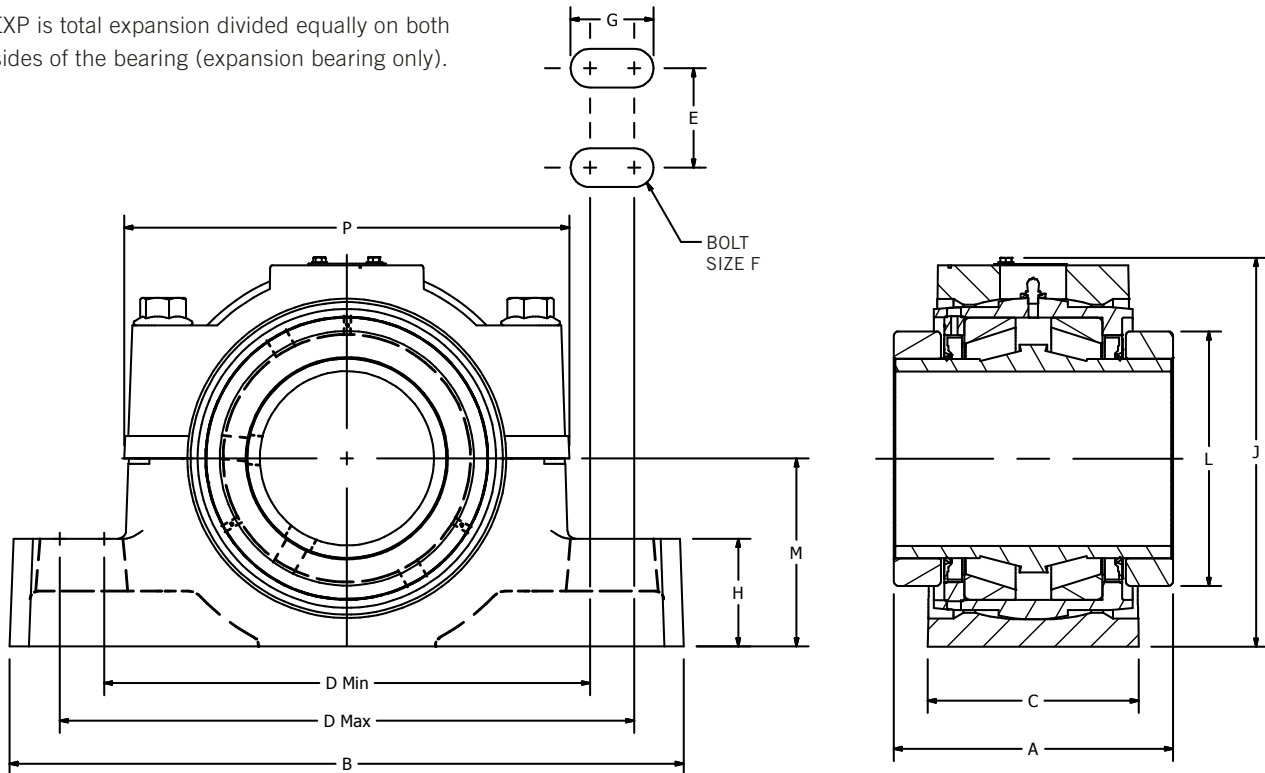

SPLIT E1000 PILLOW BLOCK TAPERED ROLLER BEARING

SHAFT SIZE	DIMENSIONS (INCHES)								WT. LBS.
	F	G	H	J	L	M	P	EXP*	
2 1/4 2 7/16 2 1/2 60mm 65mm	5/8	1 1/4	1 5/8	6 1/8	4	2.75	6 7/16	.56	30
2 11/16 2 3/4 2 15/16 3 70mm 75mm	5/8	1 3/8	1 7/8	6 13/16	4 5/8	3.13	7 1/2	.56	44
3 3/16 3 1/4 3 7/16 3 1/2 80mm 85mm 90mm	3/4	1 1/2	2 1/4	8	5 5/16	3.75	9 5/16	.56	74

TYPE E



For personal service 800.242.4633
CAD drawings at no additional charge
For nomenclature see pages 240 and 241

MOLINE BEARING CO.



SPLIT E1000 4-BOLT PILLOW BLOCK

TYPE E

SHAFT SIZE	MOLINE PART #		DIMENSIONS (INCHES)						
	EXP	NON-EXP	A	B	C	D MIN	CTR TO CTR D	D MAX	E
3 15/16 4 100mm	39342315	49342315	6.25	15 1/4	4 3/4	11	12 1/2	13	2 1/4
	39342400	49342400							
	39342100	49342100							
4 7/16 4 1/2 110mm 115mm	39342407	49342407	6.75	16 1/2	5 1/16	11 3/4	13 1/2	13 7/8	2 1/2
	39342408	49342408							
	39342110	49342110							
	39342115	49342115							
4 15/16 5 125mm	39342415	49342415	7.25	18 1/2	5 5/8	13 1/2	15 1/2	15 7/8	2 7/8
	39342500	49342500							
	39342125	49342125							

*EXP is total expansion divided equally on both sides of the bearing (expansion bearing only).

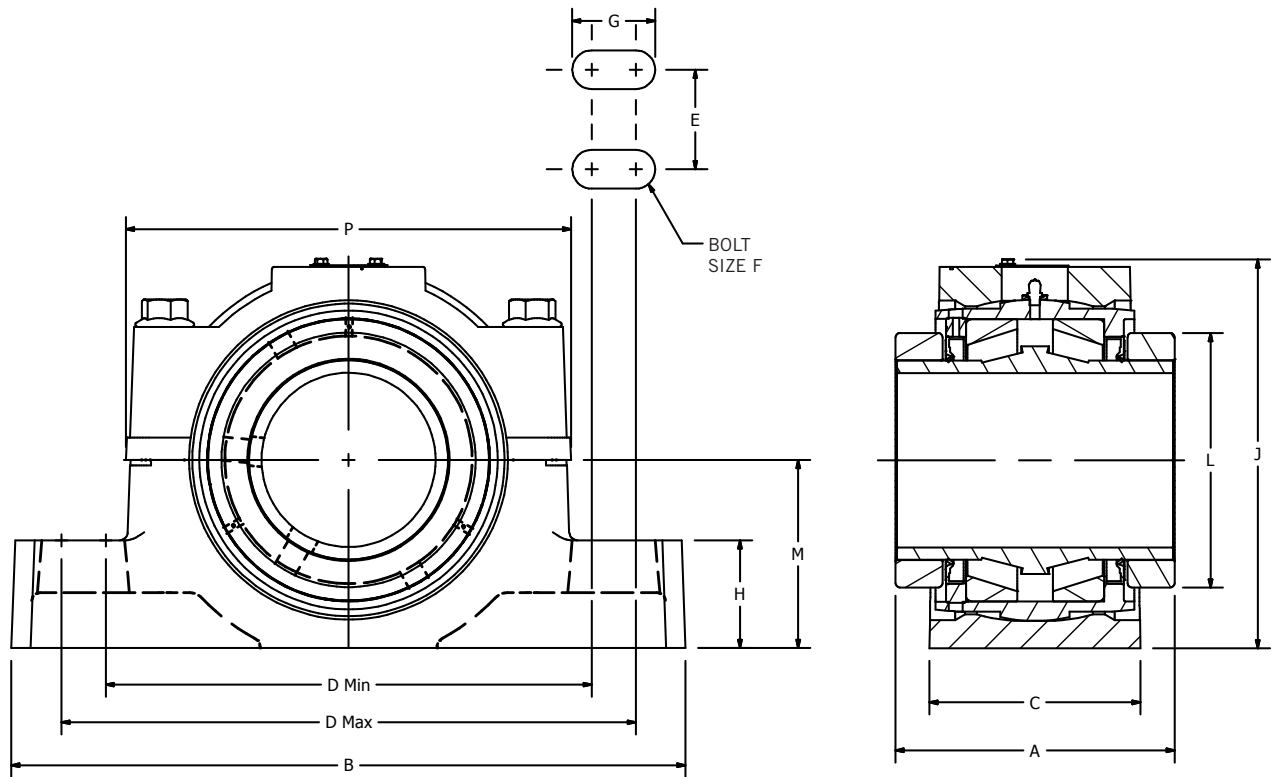

SPLIT E1000 PILLOW BLOCK TAPERED ROLLER BEARING

SHAFT SIZE	DIMENSIONS (INCHES)								WT. LBS.
	F	G	H	J	L	M	P	EXP*	
3 ¹⁵ / ₁₆ 4 100mm	³ / ₄	1 ⁷ / ₈	2 ⁷ / ₁₆	8 ¹³ / ₁₆	5 ³ / ₄	4.25	10 ¹ / ₁₆	.56	110
4 ⁷ / ₁₆ 4 ¹ / ₂ 110mm 115mm	³ / ₄	1 ¹⁵ / ₁₆	2 ³ / ₄	9 ¹³ / ₁₆	6 ¹ / ₄	4.75	11 ¹ / ₁₆	.56	153
4 ¹⁵ / ₁₆ 5 125mm	³ / ₄	2 ¹ / ₁₆	3	11 ³ / ₈	7 ¹ / ₄	5.50	12 ³ / ₄	.56	194

TYPE E

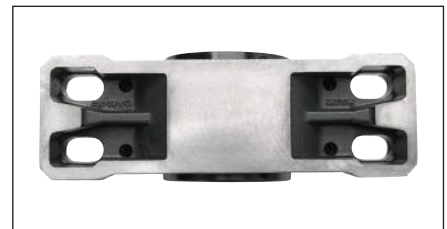

For personal service 800.242.4633
CAD drawings at no additional charge
For nomenclature see pages 240 and 241

MOLINE BEARING CO



SPLIT E1000 CARTRIDGE ASSEMBLY

with Timken® Enhanced Tapered Roller Bearings

TYPE E

SHAFT SIZE	MOLINE PART #	DIMENSIONS (INCHES)						WEIGHT LBS.
		A	B	C	E	K	L	
1 3/16	19373103	2.75	1.88	0.56	2.51	2.6370	2 1/4	3.0
1 1/4	19373104							3.0
1 3/8	19373106	3.00	2.06	0.62	3.03	3.2000	2 1/2	4.0
1 7/16	19373107							4.0
35mm	19373035							4.0
1 1/2	19373108	3.38	2.31	0.75	3.49	3.6920	2 7/8	4.0
1 5/8	19373110							6.0
1 11/16	19373111							6.0
40mm	19373040							6.0
1 3/4	19373112	3.50	2.44	0.82	3.75	3.9650	3 1/8	6.0
1 7/8	19373114							6.0
1 15/16	19373115							7.0
2	19373200							7.0
45mm	19373045							7.0
50mm	19373050							7.0
2 3/16	19373203	3.75	2.56	0.84	4.22	4.4380	3 5/8	9.0
55mm	19373055							9.0
2 1/4	19373204	4.00	2.55	0.85	4.56	4.7810	4	11.0
2 7/16	19373207							11.0
2 1/2	19373208							11.0
60mm	19373060							11.0
65mm	19373065							11.0
2 11/16	19373211	4.50	3.00	0.98	5.17	5.4325	4 5/8	16.0
2 3/4	19373212							16.0
2 15/16	19373215							16.0
3	19373300							16.0
70mm	19373070							16.0
75mm	19373075							16.0
3 3/16	19373303	5.00	3.50	1.125	6.30	6.5940	5 5/16	30.0
3 1/4	19373304							30.0
3 7/16	19373307							30.0
3 1/2	19373308							30.0
80mm	19373080							30.0
85mm	19373085							30.0
90mm	19373090							30.0



SPLIT E1000 CARTRIDGE ASSEMBLY

with Timken® Enhanced Tapered Roller Bearings

SHAFT SIZE	MOLINE PART #	DIMENSIONS (INCHES)						WEIGHT LBS.
		A	B	C	E	K	L	
3 15/16	19373315	6.25	4.50	1.56	6.84	7.2640	5 3/4	42.0
4	19373400							42.0
100mm	19373100							42.0
4 7/16	19373407	6.75	4.63	1.63	7.56	8.0000	6 1/4	56.0
4 1/2	19373408							56.0
110mm	19373110M							56.0
115mm	19373115M							56.0
4 15/16	19373415	7.25	5.13	1.87	8.79	9.2900	7 1/4	81.0
5	19373500							81.0
125mm	19373125							81.0

Split E1000 Cartridge Assembly includes Timken Cups/Cone (extended sleeve) with drive collars, set screws, shim assortment, grease fitting and cartridge stop.

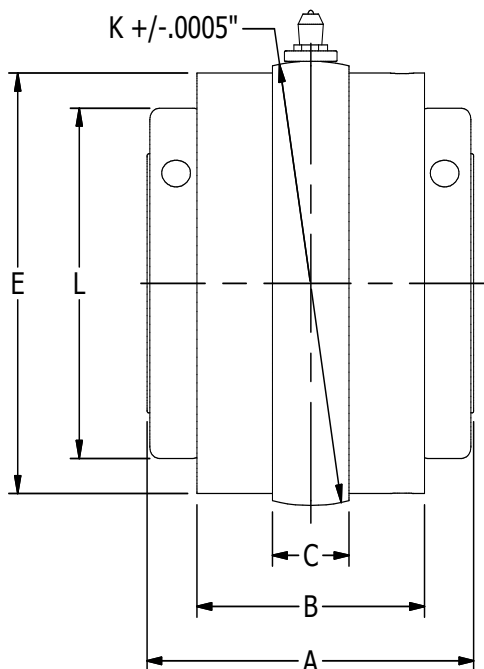

For personal service 800.242.4633
 CAD drawings at no additional charge
 For nomenclature see pages 240 and 241

MOLINE BEARING CO



TYPE E APPLICATION GUIDE

TYPE E

At Moline, our goal is to provide you with the most reliable products, helpful service, and expert support. We work to make our application guides clear and easy to understand. But if you have further questions, please contact us. 800.242.4633

LUBRICATION - VARIOUS OPERATIONS

Normal Operation

Your Moline bearing has been greased at the factory and is ready to install and run. When establishing a re-lubrication schedule, note that a small amount of grease at frequent intervals is preferable to a large amount of grease at infrequent intervals. Table 1 below is a general guide for Lubrication. It should be noted that certain conditions may require a change of lubricating periods as dictated by experience.

High Speed Operation

At higher operating speeds, too much grease may cause overheating. In these cases, the amount of lubrication can only be determined by experience. If excess grease in the bearing causes overheating, it will be necessary to remove the grease fitting and run for 10 minutes. This will allow excess grease to escape. Then wipe off excess grease and replace the grease fitting.

Operating Temperatures

Normal temperature may range from “cool or warm to the touch” up to a point of “too hot to touch for more than a few seconds,” depending on the bearing size, speed and surrounding conditions. Abnormally high bearing temperature may indicate faulty lubrication practices and/or misalignment. Unusually high temperature accompanied by excessive leakage of grease indicates too much grease. High temperature with no grease showing at the seals, particularly if the bearing is noisy, usually indicates too little grease.

Special Operating Conditions

Refer acid, chemical, extreme or other special operating conditions to the factory.

LUBRICATION INSTRUCTIONS

All Moline bearings are factory lubricated with No. 2 consistency lithium base grease that is suitable for most normal applications. Many ordinary cup greases will disintegrate at speeds far below those at which Moline bearings will operate successfully if proper grease is used. Relubricate with lithium base grease or a grease that is compatible with original lubricant and suitable for roller bearing service. It should be noted that when re-lubricating, adding a small amount of grease on a frequent basis is preferable to a large amount of grease infrequently. In unusual cases consult the factory or a reputable grease supplier.

Storage or Special Shutdown

If equipment will be idle for some time, before shutting down, add grease to the bearing, rotating the sleeve to distribute grease. If possible, cover the bearing to protect from dust and other contaminants. This will ensure protection of the bearing, particularly when exposed to severe environmental conditions. After lengthy storage, add a small amount of fresh grease before running.

TABLE 1 - LUBRICATION CHART

HOURS RUN PER DAY	SUGGESTED LUBRICATION PERIOD IN WEEKS							
	1 TO 250 RPM	251 TO 500 RPM	501 TO 750 RPM	751 TO 1000 RPM	1001 TO 1500 RPM	1501 TO 2000 RPM	2001 TO 2500 RPM	2501 TO 3000 RPM
8	12	12	10	7	5	4	3	2
16	12	7	5	4	2	2	2	1
24	12	5	3	2	1	1	1	1

Read Operations and Lubrication sections above before establishing lubrication schedule.



TYPE E APPLICATION GUIDE

After choosing the best bearing, make sure you specify the optimal grease for the application. We use premium Timken™ All Purpose lithium grease to assemble our bearings.

Moline Bearing has access to many of the differing Lubricants on the market today. If you have special or specific performance requirements from the lubricant used for your application, please contact us with the details and we will be glad to accommodate your request.



RADIAL/THRUST LOAD RATINGS

Moline Type E bearings have the capacity to carry heavy radial, thrust, and combined radial/thrust loads. The maximum recommended load which can be applied is limited by various components in the system, such as the bearing, housing, shaft, shaft attachment, speed and life requirements as listed in this catalog.

Select a bearing from the Type E Radial Load Ratings selection chart in pages 48-51 having a radial load rating at the operating speed equal to or greater than the calculated "Equivalent Radial Load" for a desired L10 life. This simple method is all that is required for the majority of applications and provides for occasional average shock loads. (Equivalent Radial Load = P). L10 Hours of Life is the life that may be expected from at least 90% of a given group of bearings operating under identical conditions.

For L10 Hours of Life other than those listed in the Type E Radial Load Ratings selection chart in pages 48-51, multiply the Equivalent radial load by one of the following factors:

For 50,000 L10 Hours of Life use the factor of 1.16; 80,000 - 1.34. Then select a bearing from the bold face (30000) L10 ratings only in the selection chart having a rating equal to or greater than this value.

TYPE E APPLICATION GUIDE CONTINUED

TYPE E

Heavy Service

For heavy shock loads, frequent shock loads or severe vibrations, add up to 50% (according to severity of conditions) to the Equivalent Radial Load to obtain a modified radial load.

Thrust load values shown in the table below are recommended as a guide for normal applications that will give adequate L10 life. Where substantial radial load is also present, it is advisable to calculate the L10 life to assure it meets the requirements. The effectiveness of the shaft attachment to carry thrust load depends on proper tightening of the set screws, shaft tolerance, and shaft deflections. Therefore, it is advisable to use auxiliary thrust carrying devices such as shaft shoulder, snap ring, or a thrust collar to locate the bearing under heavier thrust loads or where extreme reliability is desired.

RPM RANGE	20-200	201-2000	OVER 2000
Recommended Thrust Load	C90/4	C90/8	C90/12

The shaft tolerances recommended in [Table 2](#) on page 44 are adequate under normal radial, thrust, and combination radial/thrust load applications. The radial load is limited by the attachment to the shaft (see table on following page 43). Since the allowable load, especially at low speed, is very large, the shaft should be checked to assure adequate shaft strength.

The magnitude and direction of both the thrust and radial load must be taken into account when selecting a housing. When pillow blocks are utilized, heavy loads should be directed through the base. Where a load pulls the housing away from the mounting base, both the hold down bolts and housing must be of adequate strength. Auxiliary load carrying devices such as shear bars are advisable for side or end loading of pillow blocks and radial loads for flange units.

To determine the L10 hours of life for loads and RPM's not listed, use the following equation:

$$L_{10} = \left(\frac{C_{90}}{P} \right)^{10/3} \times \frac{1,500,000}{\text{RPM}}$$

Where:

L₁₀ = Life, hours

C₉₀ = Dynamic Capacity, lbs. (page 43)

P = Equivalent Radial Load, lbs.

When the load on a two row roller bearing is solely a radial load with no thrust (axial) load, the load is shared equally by both rows of rollers and the equivalent load is the same as the actual load. However, when a thrust (axial) load is applied, the loading on the two rows is shared unequally depending on the ratio of thrust to radial load. The use of the X (radial factor) and Y (thrust) factor from the table on page 43. convert the actual applied thrust and radial loads to equivalent radial load which has the same effect on the life of a bearing as a radial load of this magnitude.

$$P = XFR + YFA$$

Where:

P = Equivalent radial load, lbs.

FR = Radial load, lbs.—

(see page 37 for allowable slip fit maximum)

FA = Thrust (axial) load, lbs.

e = Thrust load to radial load factor (page 43)

X = Radial load factor (page 43)

Y = Thrust load factor (page 43)

To find X and Y, first calculate FA/FR and compare to e. Determine X and Y from the Thrust Factors and Seal Speeds chart on page 43. Light Thrust FA/FR less than or equal to e or heavy thrust FA/FR greater than e.

Substitute all known values into the equivalent radial load equation. The equivalent radial load (P) thus determined can be used in the L₁₀ life formula or compared to the allowable equivalent radial load rating desired in the expanded rating table to select a bearing.

If the calculated value of P is less than FR then use P = FR.



TYPE E APPLICATION GUIDE

Type E Thrust Factors and Seal Speeds

SHAFT SIZE	e	LIGHT THRUST IF FA/FR≤E		HEAVY THRUST IF FA/FR≥E		LOAD RATING		SEAL SPEED LIMITS		MAXIMUM SLIP FIT RADIAL LOAD FR**
		X	Y	X	Y	DYNAMIC C ₉₀ * LBS.	STATIC C ₀ LBS.	CONTACT RPM	LABYRINTH RPM	
1 - 1 ¼ 25mm	.49	.87	1.77	.70	2.14	3810	15760	3800	4490	3100
1 ⅜ - 1 ⅞ 35mm	.46	.87	1.89	.70	2.28	6100	26000	3200	3820	5000
1 ½ - 1 11/16 40mm	.44	.87	1.96	.70	2.37	7860	33000	2800	3320	6400
1 ¾ - 2 45mm 50mm	.33	.87	2.64	.70	3.18	10300	43000	2650	3050	8400
2 ⅜ 55mm	.36	.87	2.38	.70	2.87	10900	48200	2300	2730	8900
2 ¼ - 2 ½ 60mm 65mm	.40	.87	2.17	.70	2.63	11600	54000	2100	2420	9500
2 11/16 - 3 70mm 75mm	.46	.87	1.87	.70	2.26	12300	61200	1965	2060	10000
3 ⅜ - 3 ½ 80mm 85mm 90mm	.50	.87	1.71	.70	2.07	19600	108600	1640	1640	16000
3 15/16 - 4 100mm	.49	.87	1.77	.70	2.14	26900	154000	1530	1530	22000
4 7/16 - 4 ½ 110mm 115mm	.53	.87	1.63	.70	1.97	33000	188400	1360	1360	27000
4 15/16 - 5 125mm	.47	.87	1.83	.70	2.21	45500	266000	1200	1200	35000
5 7/16 - 6 130mm 135mm 140mm 150mm	.54	.87	1.76	.70	2.12	41500	354000	915	915	42400
6 7/16 - 7 160mm 170mm 180mm	.54	.87	1.61	.70	1.95	70500	574000	750	790	72000

* C90—Dynamic capacity based on a rated life of 90 million revolutions or 3,000 hours at 500 RPM.

** If load exceeds maximum allowable slip fit radial load, snug to light press fit of shaft is required.



TYPE E APPLICATION GUIDE CONTINUED

TYPE E



MOUNTING INSTRUCTIONS

It is critical to the performance of the bearing that it be mounted properly. Failure to follow proper mounting practice may result in reduced bearing life.

SHAFT DIAMETER	SHAFT TOLERANCES
1 – 1½ 35mm	Plus .0000" to minus .0005" Plus .0000" to minus .013mm
1⅝ – 4 40mm – 100mm	Plus .0000" to minus .0010" Plus .0000" to minus .025mm
4⅞ – 6 110mm – 140mm	Plus .0000" to minus .0015" Plus .0000" to minus .038mm
6⅞ – 7 160mm – 180mm	Plus .0000" to minus .0020" Plus .0000" to minus .051mm

For best results, clean the shaft and bore of the bearing. The shaft should be straight, free of burrs and nicks, and the correct size, [Table 2](#). Lubricate the shaft and bearing bore with grease or oil to facilitate assembly. Slip bearing into position. When light press fit is required, press against the end of the inner ring of bearing. Do not strike or exert pressure on the housings or seals. Bolt the unit to the support, using shims where necessary to align bearing. Use shims that cover across the entire housing base.

Determine the final shaft position and hand tighten set screws firmly onto shaft. If possible, rotate the shaft slowly under load. If there is any strain, or vibration, it could be due to incorrect alignment, a bent shaft or bent supports. Tighten set screws alternately in small increments to the torque value listed [Table 3](#). To ensure full locking of the inner race to the shaft, **after 24 hours of operation the set screws should be retightened.**

SHAFT SIZE IN	SHAFT SIZE MM	SET SCREW SIZE UNC	TORQUE (IN - LBS)
1	25	¼ – 20	80
1 ⅜ - 1 ¼	----	⅝ – 18	165
1 ⅜ - 1 ⅞	35	⅝ – 18	165
1 ½ - 1 ⅞	40	⅝ – 18	165
1 ¾ - 2	45 - 50	⅝ – 16	290
2 ⅜	55	⅝ – 16	290
2 ¼ - 2 ½	60 - 65	⅝ – 16	290
2 ⅞ - 3	70 - 75	½ – 13	620
3 ⅜ - 3 ½	80 - 90	½ – 13	620
3 ⅞ - 4	100	⅝ – 11	1325
4 ⅞ - 4 ½	110 - 115	⅝ – 11	1325
4 ⅞ - 5	125	⅝ – 11	1325
5 ⅞ - 6	130 - 150	¾ – 10	2150
6 ⅞ - 7	160 - 180	¾ – 10	2150



SPLIT E1000 MOUNTING GUIDE

FITTING OR REPLACING A CARTRIDGE IN A SPLIT E1000 PILLOW BLOCK HOUSING

1. Please note that each Moline Split E1000 Bearing has been properly assembled at the factory as a “paired” and “installation ready” Complete Unit. Top Housings and Base Housings are paired and are not interchangeable. Shims should NOT be removed.
2. When disassembling or reassembling, all component parts should be kept clean. All mating surfaces should be clean as any buildup or debris will result in incorrect bearing assembly and performance.
3. Moline Split E1000 Housings have Dowel Pins which ensure mating of the Top and Base Housings to accurately align when reassembling.

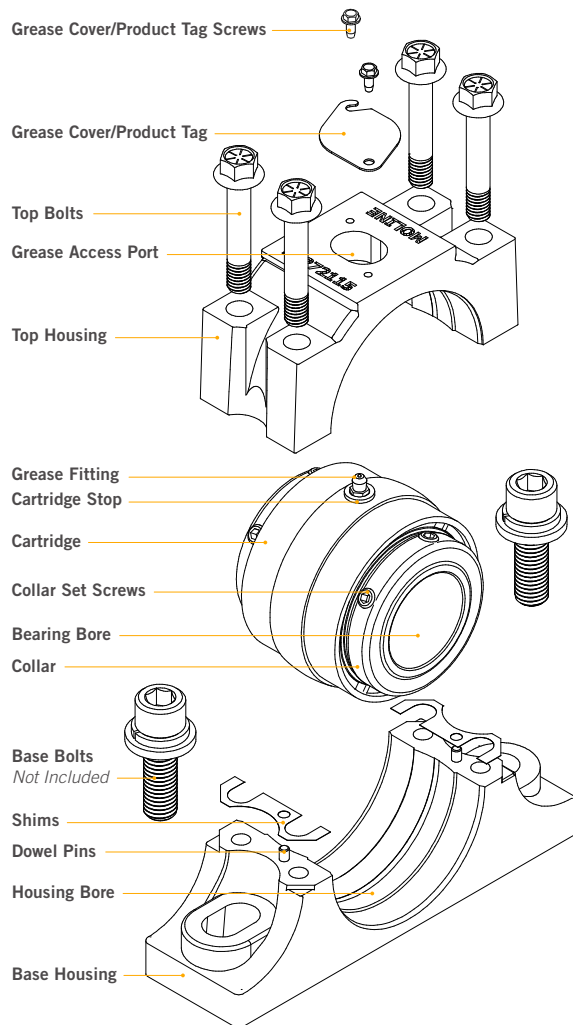

4. Prior to lubrication and assembly, ensure that the Housing Bore is free of any old buildup or debris. Lightly lubricate the Top and Base Housing Bore with Anti-Seize compound before installing the Cartridge.
5. Fit Cartridge into the mounted Base Housing making sure to center and orient the Cartridge properly. Align the Grease Fitting with the Grease Access Port in the Top Housing. Then fit the Top Housing, securing it first by loosely tightening the Top Bolts to firmly hold all of the component parts while adjusting and aligning the Cartridge and shaft.
6. If needed, and only after proper and accurate measurement, add or remove shims between Top Housing and Base Housing as required to obtain a “snug” fit of Cartridge in the Complete Unit with Top Bolts tightened to the specified torque in [Table 4](#).

TABLE 4 - TOP BOLT TORQUE (GRADE 8 BOLTS)

BORE SIZE	BOLT SIZE INCHES UNC	TORQUE FT - LBS
1 3/16 - 1 1/4	5/16 - 18	20-25
1 3/8 - 1 7/16	5/16 - 16	35-45
1 1/2 - 1 11/16	5/16 - 16	35-45
1 3/4 - 2	3/8 - 14	55-70
2 3/16	3/8 - 14	55-70
2 1/4 - 2 1/2	3/8 - 13	85-110
2 11/16 - 3	1/2 - 13	85-110
3 3/16 - 3 1/2	1/2 - 11	170-210
3 15/16 - 4	5/8 - 11	170-210
4 7/16 - 4 1/2	5/8 - 10	300-380
4 15/16 - 5	5/8 - 10	300-380



SPLIT E1000 MOUNTING GUIDE

7. Check for a “snug” fit by gently moving the Cartridge so as not to damage the grease fitting, this can be performed with a small wide blade screwdriver against the base or cartridge stop of the Grease Fitting through the Grease Access Port located in the Top Housing. Please note that care must be taken to avoid damage to the Grease Fitting due to excessive force.
8. The “snug” fit becomes a matter of judgment. A “loose” or “sloppy” fit may allow the Cartridge to move in its Top and Base Housing thus wearing the mating surfaces and Housing Bore. Too tight of a fit will not permit the unit to move and compensate for misalignment and for shaft deflection caused by belt pull and dead weight.
9. Install bearings as per the following installation instruction
6. Position and mount Base Housing to the proper mounting surface on your equipment. Insert and hand tighten Base Bolts so that the Base Housing is free to move during alignment. Once the correct position is affirmed you will tighten to your equipment’s specific torque requirements. For heavy loads and high-speed applications, use Grade 8 Base Bolts for mounting.
7. Loosen set screws in Cartridge collar and slide Cartridge into position on the shaft.
8. Accurately place the Cartridge and Shaft into the center of the Base Housing. For expansion bearings locate unit in center of its axial travel or at extreme if maximum expansion is required.

INSTALLATION OF ALL BEARINGS

1. Moline Split E1000 Bearings are assembled and shipped using Grade 8 Bolts. Use of Grade 8 Bolts allows for installation in Light, Medium and Heavy Load applications.
2. Please note that a Moline Split E1000 Bearing has been properly assembled at the factory as a “paired” and “installation ready” Complete Unit. Top Housings and Base Housings are paired and are not interchangeable. Shims should NOT be removed.
3. Clean all mating surfaces as any buildup or debris will result in inaccurate bearing assembly and performance. Inspect the Shaft, Housing Bore and Cartridge of the bearing. At this point check for burrs or nicks that would inhibit performance.
9. Keeping the Top Bolts in the Top Housing slightly loose with a proper tension will allow the Cartridge free movement to align within the Housing. If Top Bolts are too tight the Cartridge will not align properly within the Housing. If needed for proper adjustment the Base Bolts can be slightly loose during alignment so that the Complete Unit can move if needed on the shaft. Maintaining a proper tension during adjustment and setup will help prevent pre-loading or inducing an initial thrust on the bearing.
10. Check to ensure that all Base Bolts have been tightened to your equipment’s specific torque requirements.
11. Always replace the Grease Fitting protective Grease Cover/Product Tag.
12. **Within the first 24 hours of operation, recheck the Top Bolts - Table 4, Set Screws - Table 3, and Base Housing Bolts to the correct torque specifications.**

INSTALLATION FOR MEDIUM SPEEDS WITH NORMAL AND HEAVY LOADS

4. The following steps can be applied to both Expansion and Non-Expansion bearing set-up.
5. Clean the shaft and Bore. Lubricate with light oil.

INSTALLATION FOR HIGH SPEEDS WITH LIGHT LOADS

13. Follow previous steps 1 thru 12 first.
14. For applications that operate at high speeds (above 75% of rated speed) or under light loads (less than 2% of Dynamic Capacity) follow the below instructions.



SPLIT E1000 MOUNTING GUIDE

15. Due to the High Speeds and Light Loads, accurate alignment is essential.

For Expansion Units:

- Expansion type housings should be placed so the Cartridge can move freely in either direction evenly on the shaft.
- If maximum travel is needed due to greater shaft expansion move the Cartridge to the desired position. Make sure to keep the Grease fitting collar base or stop pin from hitting and restricting free movement.

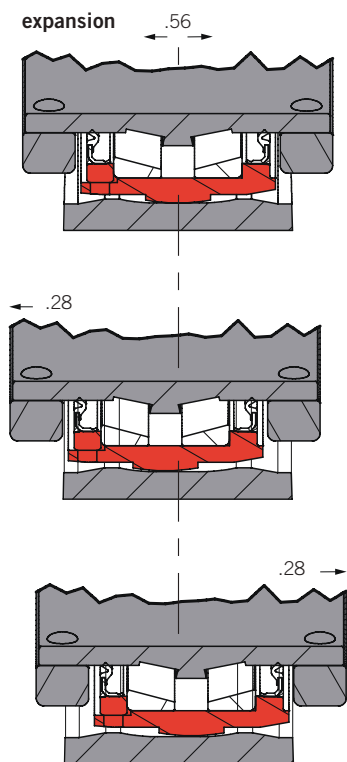

For Non-Expansion Units:

- Mount a dial indicator on the shaft near the Cartridge face. Place the dial indicator probe so that it contacts the machined surface of the Cartridge Housing, perpendicular to the face of the Cartridge.
- Zero the indicator and sweep or rotate the machined face 360°, noting the total indicator turnout.
- If the total indicator turnout is less than or equal to the value shown on Table 5, tighten the Housing Top Bolts per Table 4.

TABLE 5 - TOTAL INDICATOR RUN-OUT (TIR)

BORE SIZE	TIR
1 ³ / ₁₆ - 1 ¹ / ₄	0.0028
1 ³ / ₈ - 1 ⁷ / ₁₆	0.0030
1 ¹ / ₂ - 1 ¹¹ / ₁₆	0.0035
1 ³ / ₄ - 2	0.0040
2 ³ / ₁₆	0.0040
2 ¹ / ₄ - 2 ¹ / ₂	0.0045
2 ¹¹ / ₁₆ - 3	0.0055
3 ³ / ₁₆ - 3 ¹ / ₂	0.0065
3 ¹⁵ / ₁₆ - 4	0.0070
4 ⁷ / ₁₆ - 4 ¹ / ₂	0.0080
4 ¹⁵ / ₁₆ - 5	0.0085
5 ⁷ / ₁₆ - 7	0.0090

- If the total indicator turnout is greater than shown on Table 5, gently tap the machined face of the Cartridge Unit Housing until the total indicator turnout is less than or equal to the value shown on Table 5.
- Once Total Indicator Reading (TIR) is achieved, torque the housing Top Bolts per Table 4.
- Rotate the shaft and indicator dial again to verify that the total indicator turnout is still less than or equal to the value shown on Table 5.

- Once Cartridge is accurately placed, tighten Top Bolts to values shown in Table 4.
- Tighten Cartridge Collar Set Screws to the torque values shown in Table 3.
- Turn shaft several revolutions to allow alignment of Cartridge(s) in their respective housings. Re-check and re-tighten Top Bolts of both expansion and non-expansion Housings to recommended torque shown in Table 4.
- Proactive inspection and maintenance of all equipment is critical to healthy bearing life.
- Always replace the Grease Cover/Product Tag after lubrication.
- Within the first 24 hours of operation, recheck the Top Bolts - Table 4, Set Screws - Table 3, and Base Housing Bolts to the correct torque specifications.

TYPE E RADIAL LOAD RATINGS

TYPE E

SHAFT SIZES	L10 HOURS LIFE*	RADIAL LOAD RATINGS AT VARIOUS REVOLUTIONS PER MINUTE									
		50	100	150	250	500	750	1000	1200	1360	1530
1 1 3/16 1 1/4 25mm	10000	5297	4303	3810	3269	2655	2351	2157	2042	1966	1898
	30000	3810	3095	2740	2351	1910	1691	1551	1468	1414	1365
	40000	3495	2839	2514	2157	1752	1551	1423	1347	1297	1252
	60000	3095	2514	2226	1910	1551	1373	1260	1193	1149	1109
	100000	2655	2157	1910	1638	1331	1178	1081	1023	986	951
1 3/8 1 7/16 35mm	10000	8481	6889	6100	5233	4251	3764	3453	3269	3148	3039
	30000	6100	4955	4387	3764	3057	2707	2483	2351	2264	2186
	40000	5596	4545	4024	3453	2804	2483	2278	2157	2077	2005
	60000	4955	4024	3564	3057	2483	2199	2017	1910	1839	1775
	100000	4251	3453	3057	2623	2130	1886	1730	1638	1578	1523
1 1/2 1 5/8 1 11/16 40mm	10000	10928	8877	7860	6743	5477	4850	4449	4212	4057	3916
	30000	7860	6384	5653	4850	3939	3488	3200	3029	2918	2816
	40000	7210	5856	5186	4449	3614	3200	2935	2779	2677	2584
	60000	6384	5186	4592	3939	3200	2833	2599	2461	2370	2288
	100000	5477	4449	3939	3380	2745	2431	2230	2111	2033	1963
1 3/4 1 7/8 1 15/16 2 45mm 50mm	10000	14321	11632	10300	8837	7178	6355	5830	5520	5316	5132
	30000	10300	8366	7408	6355	5162	4571	4193	3970	3824	3691
	40000	9448	7674	6795	5830	4735	4193	3846	3642	3507	3386
	60000	8366	6795	6017	5162	4193	3713	3406	3225	3106	2998
	100000	7178	5830	5162	4429	3597	3185	2922	2766	2664	2572
2 3/16 55mm	10000	15155	12310	10900	9351	7596	6726	6170	5841	5626	5431
	30000	10900	8854	7840	6726	5463	4837	4437	4201	4046	3906
	40000	9999	8121	7191	6170	5011	4437	4070	3854	3712	3583
	60000	8854	7191	6368	5463	4437	3929	3604	3412	3287	3172
	100000	7596	6170	5463	4687	3807	3371	3092	2928	2820	2722
2 1/4 2 7/16 2 1/2 60mm 65mm	10000	16129	13100	11600	9952	8083	7158	6566	6216	5987	5779
	30000	11600	9422	8343	7158	5814	5148	4722	4471	4306	4157
	40000	10641	8643	7653	6566	5333	4722	4332	4101	3950	3813
	60000	9422	7653	6777	5814	4722	4181	3836	3631	3498	3376
	100000	8083	6566	5814	4988	4051	3587	3291	3116	3001	2897
2 11/16 2 3/4 2 15/16 3 70mm 75mm	10000	17102	13891	12300	10552	8571	7590	6962	6591	6348	6128
	30000	12300	9991	8846	7590	6165	5459	5007	4741	4566	4407
	40000	11283	9165	8115	6962	5655	5007	4593	4349	4188	4043
	60000	9991	8115	7186	6165	5007	4434	4067	3851	3709	3580
	100000	8571	6962	6165	5289	4296	3804	3489	3304	3182	3071

Note: The RED load rating values in the table indicate radial loads that exceed the Maximum Allowable Slip Fit Radial Load. Operation at these conditions may require line-to-line or light press fit on the shaft. Refer to page 43 for seal speed limits.



TYPE E RADIAL LOAD RATINGS

SHAFT SIZES	RADIAL LOAD RATINGS AT VARIOUS REVOLUTIONS PER MINUTE								
	1640	1750	2060	2420	2730	3050	3320	3820	4490
1	1859	1823	1736	1654	1596	1543	1505	1443	1374
1 3/16	1337	1311	1249	1190	1148	1110	1082	1038	988
1 1/4	1227	1203	1145	1091	1053	1018	993	952	907
25mm	1086	1065	1014	966	932	902	879	843	803
	932	914	870	829	800	774	754	723	689
35mm	2976	2919	2780	2649	2555	2471	2409	2310	-----
	2141	2099	1999	1905	1837	1777	1733	1661	-----
	1964	1926	1834	1747	1685	1630	1589	1524	-----
	1739	1705	1624	1547	1492	1444	1407	1349	-----
	1492	1463	1393	1327	1280	1238	1207	1158	-----
40mm	3835	3761	3582	3413	3292	3184	3104	-----	-----
	2758	2705	2576	2455	2367	2290	2232	-----	-----
	2530	2482	2363	2252	2172	2101	2048	-----	-----
	2241	2197	2092	1994	1923	1860	1813	-----	-----
	1922	1885	1795	1710	1650	1596	1556	-----	-----
45mm	5026	4929	4694	4472	4313	4172	-----	-----	-----
	3615	3545	3376	3217	3102	3001	-----	-----	-----
	3316	3252	3097	2951	2846	2753	-----	-----	-----
	2936	2879	2742	2613	2520	2437	-----	-----	-----
	2519	2470	2352	2241	2162	2091	-----	-----	-----
55mm	5319	5216	4967	4733	4565	-----	-----	-----	-----
	3825	3752	3572	3404	3283	-----	-----	-----	-----
	3509	3441	3277	3122	3012	-----	-----	-----	-----
	3107	3047	2902	2765	2667	-----	-----	-----	-----
	2666	2614	2489	2372	2288	-----	-----	-----	-----
60mm	5660	5551	5286	5037	-----	-----	-----	-----	-----
	4071	3992	3802	3622	-----	-----	-----	-----	-----
	3734	3662	3487	3323	-----	-----	-----	-----	-----
	3307	3243	3088	2942	-----	-----	-----	-----	-----
	2837	2782	2649	2524	-----	-----	-----	-----	-----
70mm	6002	5886	5605	-----	-----	-----	-----	-----	-----
	4317	4233	4031	-----	-----	-----	-----	-----	-----
	3960	3883	3698	-----	-----	-----	-----	-----	-----
	3506	3439	3274	-----	-----	-----	-----	-----	-----
	3008	2950	2809	-----	-----	-----	-----	-----	-----
75mm	6002	5886	5605	-----	-----	-----	-----	-----	-----
	4317	4233	4031	-----	-----	-----	-----	-----	-----
	3960	3883	3698	-----	-----	-----	-----	-----	-----
	3506	3439	3274	-----	-----	-----	-----	-----	-----
	3008	2950	2809	-----	-----	-----	-----	-----	-----

Note: Because the allowable loads, especially at low speeds, are extremely high, be sure the shaft strength is adequate and pillow blocks are base loaded. When imposed load is horizontal, be sure hold-down bolts are adequate. If bearings are cap loaded, full details on load, speed and shaft size should be referred to Moline Bearing Company. Consult Moline for speeds and loads greater than listed.

*“Minimum Hours Life” (L10) is the life expected from at least 90% of a given group of bearings operating under identical conditions (proper installation, correct alignment and maintenance). Average life will be approximately five times the minimum life.

TYPE E



TYPE E RADIAL LOAD RATINGS CONTINUED

TYPE E

SHAFT SIZES	L10 HOURS LIFE*	RADIAL LOAD RATINGS AT VARIOUS REVOLUTIONS PER MINUTE									
		50	100	150	200	500	750	1000	1200	1360	1530
3 3/16											
3 1/4	10000	27252	22135	19600	16815	13658	12094	11094	10503	10116	9765
3 7/16	30000	19600	15920	14097	12094	9823	8698	7979	7554	7276	7023
3 1/2	40000	17979	14604	12931	11094	9011	7979	7319	6930	6674	6443
80mm	60000	15920	12931	11450	9823	7979	7065	6481	6136	5910	5705
85mm	100000	13658	11094	9823	8428	6845	6061	5560	5264	5070	4894
	10000	37401	30379	26900	23078	18745	16598	15226	14415	13884	13402
3 15/16	30000	26900	21850	19347	16598	13482	11938	10951	10368	9986	9639
4	40000	24676	20043	17747	15226	12367	10951	10045	9511	9160	8842
100mm	60000	21850	17747	15715	13482	10951	9697	8895	8421	8111	7829
	100000	18745	15226	13482	11566	9395	8319	7631	7225	6959	6717
	10000	45883	37268	33000	28311	22996	20362	18678	17684	17033	----
4 7/16	30000	33000	26804	23734	20362	16539	14645	13434	12719	12250	----
4 1/2	40000	30271	24588	21772	18678	15172	13434	12323	11667	11237	----
110mm	60000	26804	21772	19278	16539	13434	11895	10912	10331	9950	----
115mm	100000	22996	18678	16539	14189	11525	10205	9361	8863	8536	----
	10000	63263	51385	45500	39035	31706	28075	25754	24383	----	----
4 15/16	30000	45500	36957	32725	28075	22804	20192	18523	17537	----	----
5	40000	41738	33902	30019	25754	20918	18523	16991	16087	----	----
125mm	60000	36957	30019	26581	22804	18523	16401	15045	14244	----	----
	100000	31706	25754	22804	19564	15891	14071	12907	12220	----	----
	10000	57579	46769	41412	35528	28858	25553	23440	----	----	----
5 15/16	30000	41412	33637	29784	25553	20755	18378	16858	----	----	----
6	40000	37988	30856	27322	23440	19039	16858	15464	----	----	----
130mm	60000	33637	27322	24193	20755	16858	14928	13693	----	----	----
135mm	100000	28858	23440	20755	17806	14463	12807	11748	----	----	----
140mm											
150mm											
	10000	97981	79585	70470	60457	49107	43482	----	----	----	----
6 7/16	30000	70470	57239	50684	43482	35319	31274	----	----	----	----
6 15/16	40000	64643	52507	46493	39887	32398	28688	----	----	----	----
7	60000	57239	46493	41168	35319	28688	25402	----	----	----	----
160mm	100000	49107	39887	35319	30300	24612	21793	----	----	----	----
170mm											
180mm											

Note: The RED load rating values in the table indicate radial loads that exceed the Maximum Allowable Slip Fit Radial Load. Operation at these conditions may require line-to-line or light press fit on the shaft. Refer to page 43 for seal speed limits.



TYPE E RADIAL LOAD RATINGS

SHAFT SIZES	RADIAL LOAD RATINGS AT VARIOUS REVOLUTIONS PER MINUTE								
	1640	1750	2060	2420	2730	3050	3320	3820	4490
3 3/16									
3 1/4	9564	-----	-----	-----	-----	-----	-----	-----	-----
3 7/16	6879	-----	-----	-----	-----	-----	-----	-----	-----
3 1/2	6310	-----	-----	-----	-----	-----	-----	-----	-----
80mm	5587	-----	-----	-----	-----	-----	-----	-----	-----
85mm	4793	-----	-----	-----	-----	-----	-----	-----	-----
90mm									
3 15/16	-----	-----	-----	-----	-----	-----	-----	-----	-----
4	-----	-----	-----	-----	-----	-----	-----	-----	-----
100mm	-----	-----	-----	-----	-----	-----	-----	-----	-----
	-----	-----	-----	-----	-----	-----	-----	-----	-----
4 7/16	-----	-----	-----	-----	-----	-----	-----	-----	-----
4 1/2	-----	-----	-----	-----	-----	-----	-----	-----	-----
110mm	-----	-----	-----	-----	-----	-----	-----	-----	-----
115mm	-----	-----	-----	-----	-----	-----	-----	-----	-----
	-----	-----	-----	-----	-----	-----	-----	-----	-----
4 15/16	-----	-----	-----	-----	-----	-----	-----	-----	-----
5	-----	-----	-----	-----	-----	-----	-----	-----	-----
125mm	-----	-----	-----	-----	-----	-----	-----	-----	-----
	-----	-----	-----	-----	-----	-----	-----	-----	-----
5 7/16									
5 15/16	-----	-----	-----	-----	-----	-----	-----	-----	-----
6	-----	-----	-----	-----	-----	-----	-----	-----	-----
130mm	-----	-----	-----	-----	-----	-----	-----	-----	-----
135mm	-----	-----	-----	-----	-----	-----	-----	-----	-----
140mm	-----	-----	-----	-----	-----	-----	-----	-----	-----
150mm	-----	-----	-----	-----	-----	-----	-----	-----	-----
	-----	-----	-----	-----	-----	-----	-----	-----	-----
6 7/16									
6 1/2	-----	-----	-----	-----	-----	-----	-----	-----	-----
6 15/16	-----	-----	-----	-----	-----	-----	-----	-----	-----
7	-----	-----	-----	-----	-----	-----	-----	-----	-----
160mm	-----	-----	-----	-----	-----	-----	-----	-----	-----
170mm	-----	-----	-----	-----	-----	-----	-----	-----	-----
180mm	-----	-----	-----	-----	-----	-----	-----	-----	-----

Note: Because the allowable loads, especially at low speeds, are extremely high, be sure the shaft strength is adequate and pillow blocks are base loaded. When imposed load is horizontal, be sure hold-down bolts are adequate. If bearings are cap loaded, full details on load, speed and shaft size should be referred to Moline Bearing Company. Consult Moline for speeds and loads greater than listed.

*“Minimum Hours Life” (L10) is the life expected from at least 90% of a given group of bearings operating under identical conditions (proper installation, correct alignment and maintenance). Average life will be approximately five times the minimum life.

TYPE E



TYPE E SERIES INTERCHANGE

Type E Series Interchange

MOLINE*	BROWNING*	ROYERSFORD*	SEALMASTER*	TIMKEN*	DODGE
2-Bolt Pillow Block 19321 (Pages 14–15)	PBE920 True Type E	20-02-0** True Type E	EPB-2 True Type E	E-P2B-TRB** True Type E	P2BE**
4-Bolt Pillow Block 19341 (Pages 16–19)	PBE920F** True Type E	20-04-0 True Type E	EPB-4** True Type E	E-P4B-TRB True Type E	P4BE
4-Bolt Flange 19311 (Pages 20–23)	FBE920 True Type E	20-05-0 True Type E	EFB True Type E	E-4BF-TRB True Type E	F4BE
Piloted Flange 19331 (Pages 24–25)	----- -----	20-06-0 True Type E	----- -----	E-PF-TRB True Type E	FCE
Wide Slot Take-Up 19351 (Pages 26–27)	TUE920 True Type E	20-07-0 True Type E	ETU True Type E	E-TU-TRB True Type E	WSTUE

* True Type E = Timken Cup/Cone Assembly (extended sleeve) and double collar.

** Denotes pillow block center to center dimension slightly different.

Moline Type E can be dimensionally interchanged with the Moline ME2000 and ME3000.

Split E1000 Type E Series Interchange

MOLINE*	MOLINE PREFIX	DODGE	SEALMASTER**
2-Bolt Pillow Block (Pages 30–33)	39322 (Expansion) 49322 (Non-Expansion)	P2B-EXL-RE P2B-EXL-R	ERP2B-2 RPB-2
4-Bolt Pillow Block (Pages 34–37)	39342 (Expansion) 49342 (Non-Expansion)	P4B-EXL-RE P4B-EXL-R	ERP4B-4 RPB-4

* True Type E = Cartridge assembled with Timken Enhanced DEE Cone (highest load rating), made in the USA.

** True Type E = Cartridge assembled with Timken DE Cone.

Can dimensionally interchange with standard Moline Type E, ME2000 and ME3000 Pillow Block Units.

This is a general dimensional interchange, for exact comparison information, please contact the factory.

For Nomenclature see pages 240-241.





M2000

SPHERICAL
ROLLER
BEARINGS

Moline M2000 Mounted Spherical Roller Bearings are suitable for a wide variety of applications. They work exceptionally well in situations where a high capacity align-able bearing is required. They are available in a wide range of shaft sizes and a variety of popular mounts.

Moline M2000 Pillow Blocks, 4-Bolt Flange Bearings, Piloted Flange Bearings and Wide Slot Take-up Bearings are ready to slip onto the shaft when received because they are completely assembled, adjusted, sealed and pre-lubricated at the factory. The self-aligning feature provides for speedy mounting with a minimum of field adjustment required. The housings are ruggedly designed and made in the USA of Class 30 cast iron. There is no danger of bearing failure resulting from dirt or dust entering the bearing before or during installation. Such contamination is very difficult to prevent in bearings that are not shaft ready. No time or expense is required for cleaning housings or initial lubrication. Therefore, overall cost is less in many instances. Operating expense over time is also generally less.

Our M2000 bearings are interchangeable with other collar mounted spherical roller bearings in single piece housings, and are equipped with bearings that have excellent load characteristics.

Standard on all Moline M2000 bearings is a specially designed triple-lip contact seal that prohibits entry of contaminants, retains lubrication and is self-purging. In addition, these bearings are also available with a spring loaded Garter seal for extreme conditions and a balanced Labyrinth seal for high-speed applications.

Moline M2000 bearings are available in expansion (red metal tag) and non-expansion (yellow metal tag) styles. The expansion units have the capacity to move up to .100". The bearings are available in shaft sizes from 1³/₁₆" up to 5" and 40 to 130mm.

All Moline housings come with a standard paint finish. Custom Colors, Powder Coating, Stainless Steel Powder coating, Nickel plating, Epoxy and Teflon coatings will be quoted on request.

Moline M2000 mounted bearings are carried in Moline warehouses and distributor stocks throughout the United States and in Canada.

Set screws secure cone to shaft

Large diameter rollers for optimum capacity

Solid cast iron housing with center support
Made in the USA

Triple-lip contact type seals

Elongated bolt holes permit adjustment and increased mounting options

MOLINE M2000 SPHERICAL ROLLER BEARINGS

SKF SKF INSERT INSIDE

TIMKEN TIMKEN INSERT INSIDE



FEATURES OF MOLINE M2000 SPHERICAL ROLLER BEARINGS

WITH SKF® OR TIMKEN™ ROLLER BEARINGS

- For applications that require expansion and misalignment capability
- Dimensionally interchangeable with competitive Spherical Roller Bearing units, Moline M3000
- Suggested Industry Applications: Conveying, Screening, Air Handling, Food Processing, Paper and Forestry
- Available in shaft sizes from 1-¹³/₁₆" to 5"; and 40mm to 130mm
- Assembled, adjusted and pre-lubricated in advance for immediate use
- Machined and assembled in the USA
- Built with SKF™ and Timken™ Spherical Roller Bearings
- Standard units have one Locking Collar, Double Collar Spherical (D) insert option is available
- +/- 1½° misalignment capacity
- Available in Expansion (red tag) and Non-Expansion (yellow tag) styles
- Expansion units have .100" capacity
- Will accommodate moderate thrust loads and permits angular misalignment without loss of capacity
- Piloted Flange housings are machined with back-out holes
- Single piece outer race is grooved and has 3 lube holes for even distribution of grease)
- Precision ground contours
- Rotating center guide ring for least possible friction
- Available with Standard Triple Lip Contact, Balanced Steel and Teflon Labyrinth, and Spring Loaded Garter Seals
- Timken™ Lithium Complex Grease operating temperature is up to 250°, High temperature grease is available up to 350°
- For custom lubrication, please see page 154 or contact the factory for more information
- Housings of Class 30 Cast Iron made in Illinois, Iowa and Wisconsin
- Housings available in the standard painted finish. Powder coating in RAL or custom colors, Stainless Steel Powder coating, Nickel-plating, Epoxy, Teflon and other coatings are available. See page 150 or contact the factory
- Custom machining and design service are available. See page 146 or contact the factory for further information
- Made in the United States



M2000 2-BOLT PILLOW BLOCK, SINGLE AND DOUBLE COLLAR

SHAFT SIZE	MOLINE PART #		DIMENSIONS (INCHES)					
	EXP	NON-EXP	A	B	C	MIN D	CENTER TO CENTER D	MAX D
1 3/16	19121103	19221103	2 7/8	6 7/8	2 3/16	4 11/16	5	5 5/16
1 1/4	19121104	19221104						
1 7/16	19121107	19221107						
1 1/2	19121108	19221108						
1 11/16	19121111	19221111	3	7 3/8	2 3/16	5 3/16	5 1/2	5 13/16
1 3/4	19121112	19221112						
40mm	19121040	19221040						
45mm	19121045	19221045						
1 15/16	19121115	19221115	3	8 3/8	2 3/16	5 15/16	6 1/4	6 9/16
2	19121200	19221200						
50mm	19121050	19221050						
2 3/16	19121203	19221203	3 1/4	8 7/8	2 1/2	6 7/16	6 3/4	7 1/16
2 1/4	19121204	19221204						
55mm	19121055	19221055						
2 7/16	19121207	19221207	3 1/2	9 1/4	2 3/4	6 13/16	7 1/8	7 7/16
2 1/2	19121208	19221208						
60mm	19121060	19221060						
65mm	19121065	19221065						

Starting at Sizes 1 15/16 add Suffix "D" to part number for Double Collar Spherical assembly.
Assembled with Timken™ Spherical Roller Bearings.

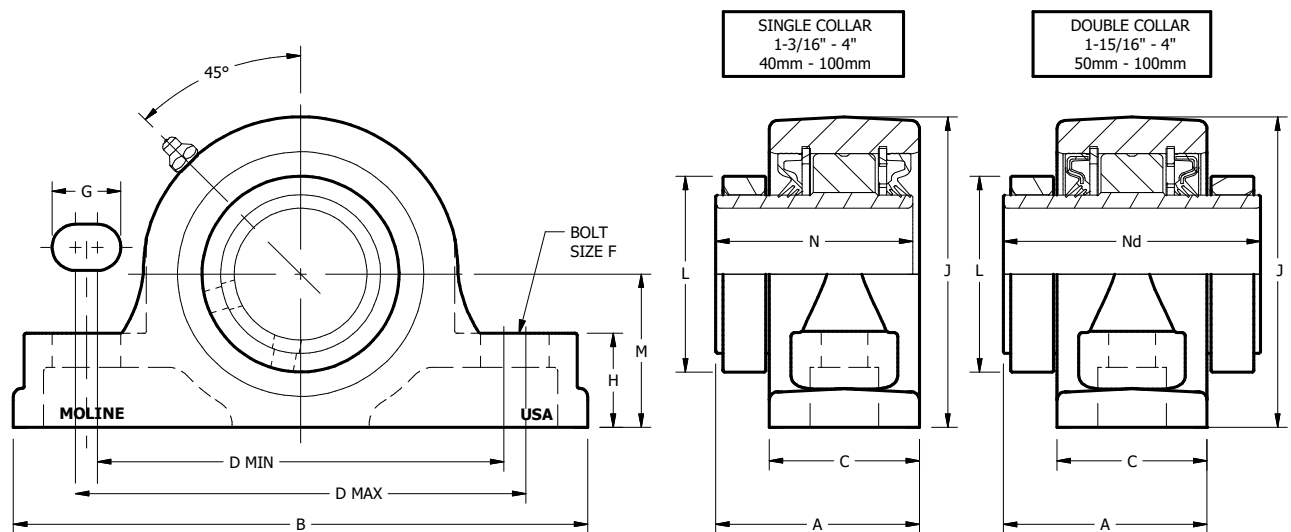

M2000 2-BOLT PILLOW BLOCK, SINGLE AND DOUBLE COLLAR

SHAFT SIZE	DIMENSIONS (INCHES)								WEIGHT LBS.
	F	G	H	J	L	M	N SINGLE	Nd DOUBLE	
1 3/16 1 1/4 1 7/16 1 1/2	1/2	15/16	1 3/16	3 7/8	2 1/2	1 7/8	2 3/4	----	6.5
6.5									
6.9									
6.9									
1 11/16 1 3/4 40mm 45mm	1/2	15/16	1 5/16	4 1/4	2 5/8	2 1/8	2 7/8	----	8.1
8.1									
8.1									
8.1									
1 15/16 2 50mm	5/8	1	1 3/8	4 9/16	2 7/8	2 1/4	2 7/8	3 3/4	9.1
9.1									
9.1									
9.1									
2 3/16 2 1/4 55mm	5/8	1	1 5/8	5	3 1/4	2 1/2	3 1/8	4	11.8
11.8									
11.8									
11.8									
2 7/16 2 1/2 60mm 65mm	5/8	1	1 3/4	5 11/16	4	2 3/4	3 3/8	4 5/16	16.2
16.2									
16.2									
16.2									



M2000 SPHERICALS

For personal service 800.242.4633
 CAD drawings at no additional charge
 For nomenclature see pages 240 and 241

MOLINE BEARING CO.



M2000 2-BOLT PILLOW BLOCK, SINGLE AND DOUBLE COLLAR

SHAFT SIZE	MOLINE PART #		DIMENSIONS (INCHES)					
	EXP	NON-EXP	A	B	C	MIN D	CENTER TO CENTER D	MAX D
2 1/16	19121211	19221211	3 13/16	10 1/2	2 13/16	7 13/16	8 1/8	8 7/16
2 3/4	19121212	19221212						
2 15/16	19121215	19221215						
3	19121300	19221300						
70mm	19121070	19221070						
75mm	19121075	19221075						
3 3/16	19121303	19221303	4 1/4	13	3 1/4	9 1/2	10	10 1/2
3 7/16	19121307	19221307						
3 1/2	19121308	19221308						
80mm	19121080	19221080						
85mm	19121085	19221085						
90mm	19121090	19221090						
3 11/16	19121311	19221311	4 3/4	14 1/2	3 9/16	10	10 7/8	11 3/4
3 15/16	19121315	19221315						
4	19121400	19221400						
100mm	19121100	19221100						

Starting at Sizes 1 15/16 add Suffix "D" to part number for Double Collar Spherical assembly.
Assembled with Timken™ Spherical Roller Bearings.

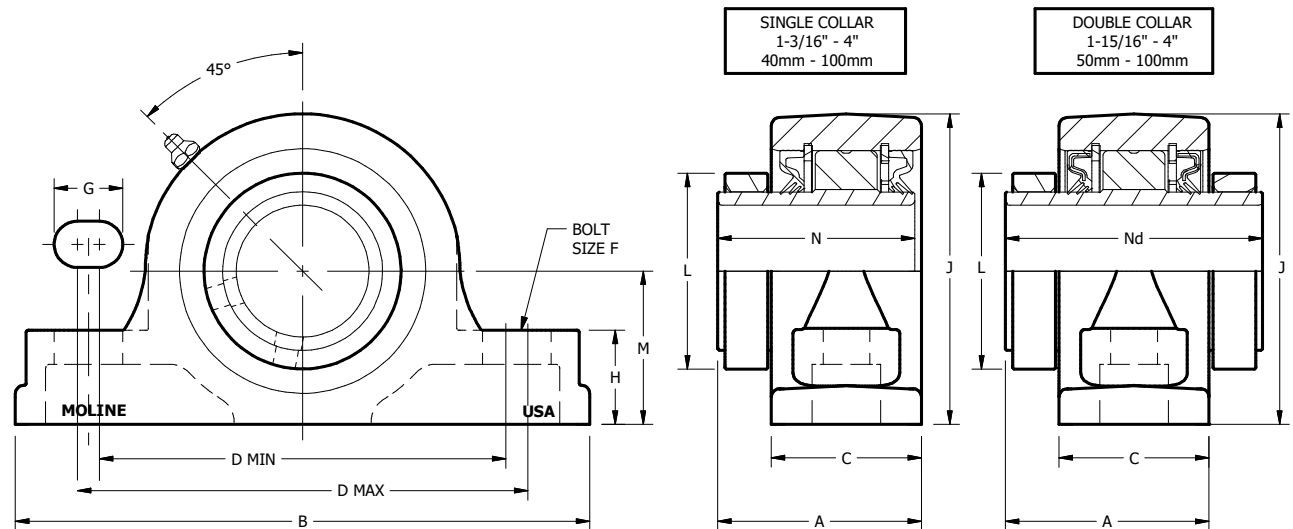

M2000 2-BOLT PILLOW BLOCK, SINGLE AND DOUBLE COLLAR

SHAFT SIZE	DIMENSIONS (INCHES)								WEIGHT LBS.
	F	G	H	J	L	M	N SINGLE	Nd DOUBLE	
2 1/16 2 3/4 2 15/16 3 70mm 75mm	3/4	1 1/8	2 1/4	6 7/16	4 3/8	3 1/4	3 5/8	4 3/4	22.1
3 3/16 3 7/16 3 1/2 80mm 85mm 90mm	7/8	1 7/16	2 1/4	7 1/2	5 1/8	3 3/4	4 1/32	5 3/16	31.6
3 11/16 3 15/16 4 100mm	1	1 15/16	2 1/2	8 3/8	6	4 1/8	4 19/32	5 15/16	45



M2000 SPHERICALS

For personal service 800.242.4633
 CAD drawings at no additional charge
 For nomenclature see pages 240 and 241

MOLINE BEARING CO



M2000 4-BOLT PILLOW BLOCK, SINGLE AND DOUBLE COLLAR

SHAFT SIZE	MOLINE PART #		DIMENSIONS (INCHES)						
	EXP	NON-EXP	A	B	C	MIN D	CENTER TO CENTER D	MAX D	E
2 7/16	19141207	19241207	3 3/4	9 1/4	3 1/4	6 7/8	7 1/4	7 5/8	1 3/4
2 1/2	19141208	19241208							
60mm	19141060	19241060							
65mm	19141065	19241065							
2 11/16	19141211	19241211	4 1/4	10 1/2	3 3/4	7 7/8	8 1/8	8 3/8	1 7/8
2 3/4	19141212	19241212							
2 15/16	19141215	19241215							
3	19141300	19241300							
70mm	19141070	19241070							
75mm	19141075	19241075							
3 3/16	19141303	19241303	4 9/16	13	3 7/8	9 1/4	10	10 3/4	2
3 7/16	19141307	19241307							
3 1/2	19141308	19241308							
80mm	19141080	19241080							
85mm	19141085	19241085							
90mm	19141090	19241090							

Starting at Sizes 2 7/16 add Suffix "D" to part number for Double Collar Spherical assembly.
Assembled with Timken™ Spherical Roller Bearings.

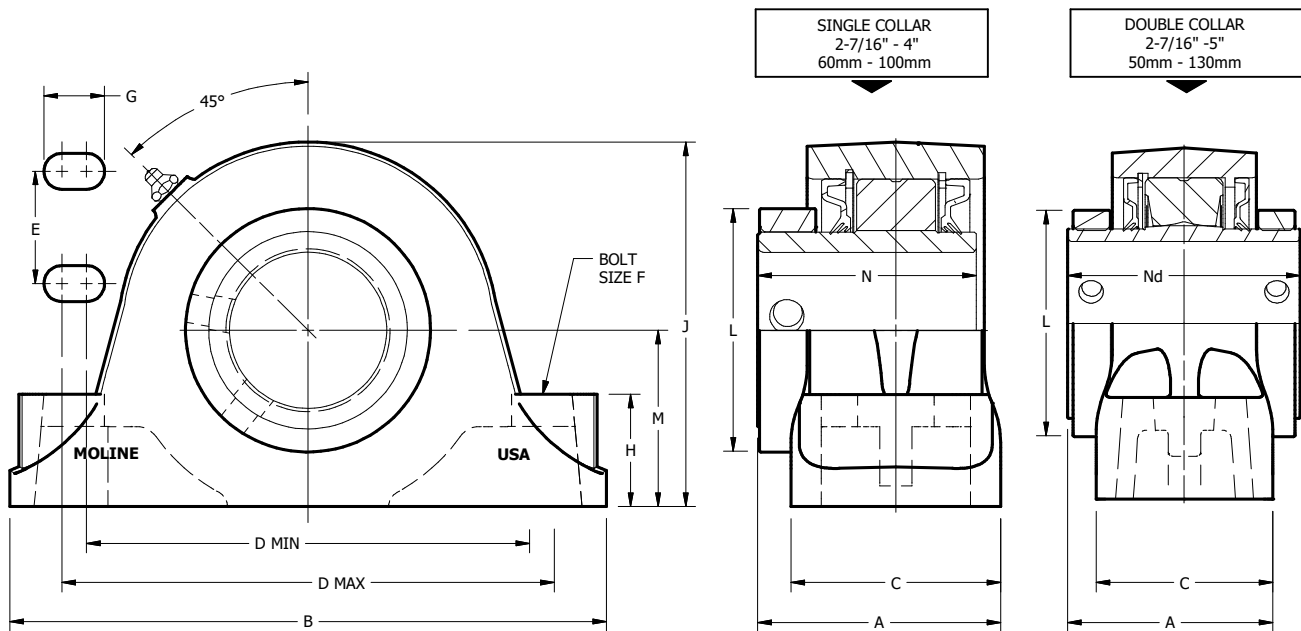

M2000
SPHERICALS

M2000 4-BOLT PILLOW BLOCK, SINGLE AND DOUBLE COLLAR

SHAFT SIZE	DIMENSIONS (INCHES)								WEIGHT LBS.
	F	G	H	J	L	M	N SINGLE	Nd DOUBLE	
$2\frac{7}{16}$ $2\frac{1}{2}$ 60mm 65mm	$\frac{1}{2}$	$1\frac{5}{16}$	$1\frac{3}{4}$	$5\frac{11}{16}$	4	$2\frac{3}{4}$	$3\frac{3}{8}$	$4\frac{5}{16}$	17
$2\frac{11}{16}$ $2\frac{3}{4}$ $2\frac{15}{16}$ 3 70mm 75mm	$\frac{5}{8}$	$1\frac{5}{16}$	$2\frac{1}{4}$	$6\frac{7}{16}$	$4\frac{3}{8}$	$3\frac{1}{4}$	$3\frac{5}{8}$	$4\frac{3}{4}$	26
$3\frac{3}{16}$ $3\frac{7}{16}$ $3\frac{1}{2}$ 80mm 85mm 90mm	$\frac{3}{4}$	$1\frac{9}{16}$	$2\frac{1}{4}$	$7\frac{1}{2}$	$5\frac{1}{8}$	$3\frac{3}{4}$	$4\frac{1}{32}$	$5\frac{3}{16}$	38



M2000 SPHERICALS

For personal service 800.242.4633
 CAD drawings at no additional charge
 For nomenclature see pages 240 and 241

MOLINE BEARING CO



M2000 4-BOLT PILLOW BLOCK, SINGLE AND DOUBLE COLLAR

SHAFT SIZE	MOLINE PART #		DIMENSIONS (INCHES)						
	EXP	NON-EXP	A	B	C	MIN D	CENTER TO CENTER D	MAX D	E
3 1/16	19141311	19241311	5 1/4	15 1/4	4 1/2	11	12	13	2 1/4
3 15/16	19141315	19241315							
4	19141400	19241400							
100mm	19141100	19241100							
4 7/16	19141407	19241407	5 1/2	16 1/2	4 3/4	13	13 1/2	14	2 1/2
4 1/2	19141408	19241408							
110mm	19141110	19241110							
115mm	19141115	19241115							
4 15/16	19141415	19241415	6 1/16	18 5/8	5 3/8	15	15 1/2	16	2 3/4
5	19141500	19241500							
125mm	19141125	19241125							
130mm	19141130	19241130							

Starting at Sizes 2 7/16 add Suffix "D" to part number for Double Collar Spherical assembly.
Assembled with Timken™ Spherical Roller Bearings.

M2000 SPHERICALS

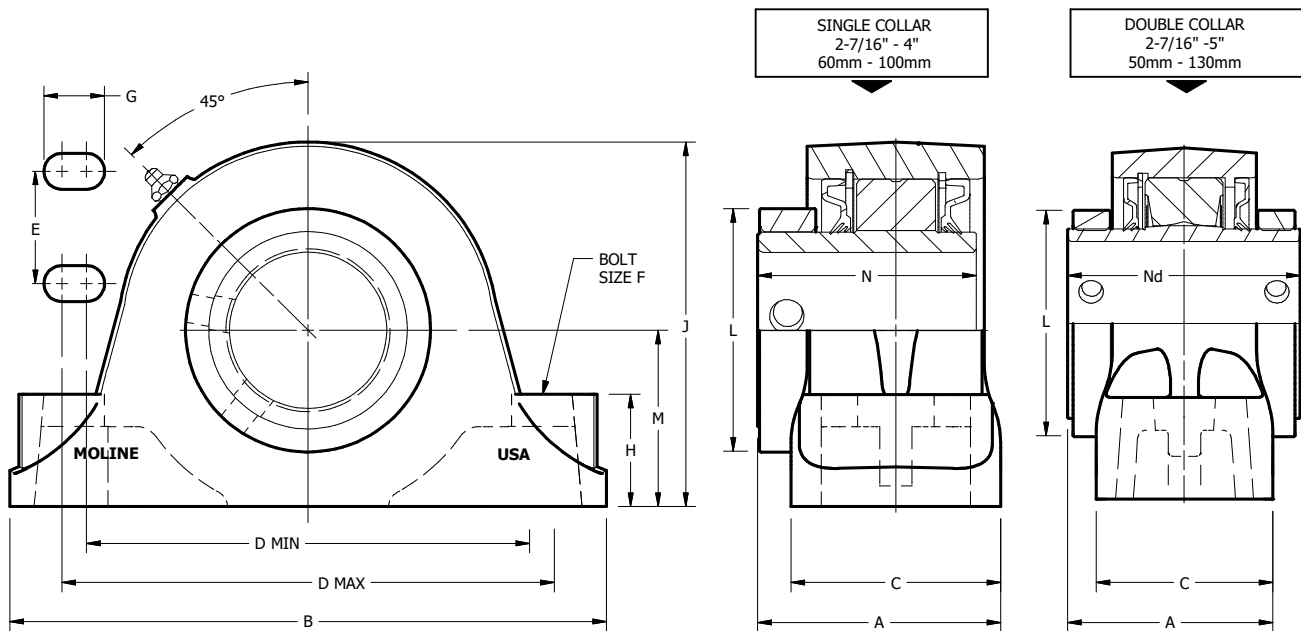

M2000 4-BOLT PILLOW BLOCK, SINGLE AND DOUBLE COLLAR

SHAFT SIZE	DIMENSIONS (INCHES)								WEIGHT LBS.
	F	G	H	J	L	M	N SINGLE	Nd DOUBLE	
3 1/16 3 15/16 4 100mm	3/4	1 13/16	2 5/8	8 1/2	6	4 1/4	4 19/32	5 15/16	50
4 7/16 4 1/2 110mm 115mm	3/4	1 5/16	2 3/4	9 1/2	6 1/8	4 3/4	----	6 1/4	72
4 15/16 5 125mm 130mm	7/8	1 1/2	3	11 1/8	6 7/8	5 1/2	----	7 7/16	107



M2000
SPHERICALS

For personal service 800.242.4633
CAD drawings at no additional charge
For nomenclature see pages 240 and 241

MOLINE BEARING CO



M2000 4-BOLT FLANGE, SINGLE AND DOUBLE COLLAR

SHAFT SIZE	MOLINE PART #		DIMENSIONS (INCHES)											WT. LBS.
	EXP	NON-EXP	A	B	C	D	E	F	H	J	L	N SINGLE	Nd DOUBLE	
1 3/16	19111103	19211103	2 15/16	4 5/8	2 1/4	3 17/32	5	1/2	3/4	3 7/8	2 1/2	2 3/4	----	7
1 1/4	19111104	19211104												
1 7/16	19111107	19211107												
1 1/2	19111108	19211108												
1 11/16	19111111	19211111	3 1/16	5	2 1/4	3 57/64	5 1/2	1/2	3/4	4 1/4	2 5/8	2 7/8	----	10
1 3/4	19111112	19211112												
40mm	19111040	19211040												
45mm	19111045	19211045												
1 15/16	19111115	19211115	3 1/32	5 1/4	2 1/4	4 1/16	5 3/4	1/2	3/4	4 1/2	2 7/8	2 7/8	3 3/4	10.5
2	19111200	19211200												
50mm	19111050	19211050												
2 3/16	19111203	19211203	3 9/32	5 7/8	2 7/16	4 1/2	6 3/8	5/8	3/4	5	3 1/4	3 1/8	4	12.5
2 1/4	19111204	19211204												
55mm	19111055	19211055												
2 7/16	19111207	19211207	3 9/16	6 1/8	2 3/4	4 25/32	6 3/4	5/8	1	5 3/4	4	3 3/8	4 5/16	16.5
2 1/2	19111208	19211208												
60mm	19111060	19211060												
65mm	19111065	19211065												
2 11/16	19111211	19211211	3 15/16	7 1/4	2 7/8	5 9/16	7 7/8	3/4	1	6 5/8	4 3/8	3 5/8	4 3/4	25
2 3/4	19111212	19211212												
2 15/16	19111215	19211215												
3	19111300	19211300												
70mm	19111070	19211070												
75mm	19111075	19211075												
3 3/16	19111303	19211303	4 11/32	8 3/8	3 1/4	6 23/32	9 1/2	3/4	1 1/8	7 5/8	5 1/8	4 1/32	5 3/16	35
3 7/16	19111307	19211307												
3 1/2	19111308	19211308												
80mm	19111080	19211080												
85mm	19111085	19211085												
90mm	19111090	19211090												
3 11/16	19111311	19211311	4 7/8	9 1/2	3 9/16	7 19/32	10 3/4	7/8	1 3/16	8 3/8	6	4 19/32	5 15/16	48
3 15/16	19111315	19211315												
4	19111400	19211400												
100mm	19111100	19211100												

Starting at Sizes 1 15/16 add Suffix "D" to part number for Double Collar Spherical assembly.

Assembled with SKF™ Spherical Roller Bearings.



M2000 4-BOLT FLANGE, SINGLE AND DOUBLE COLLAR

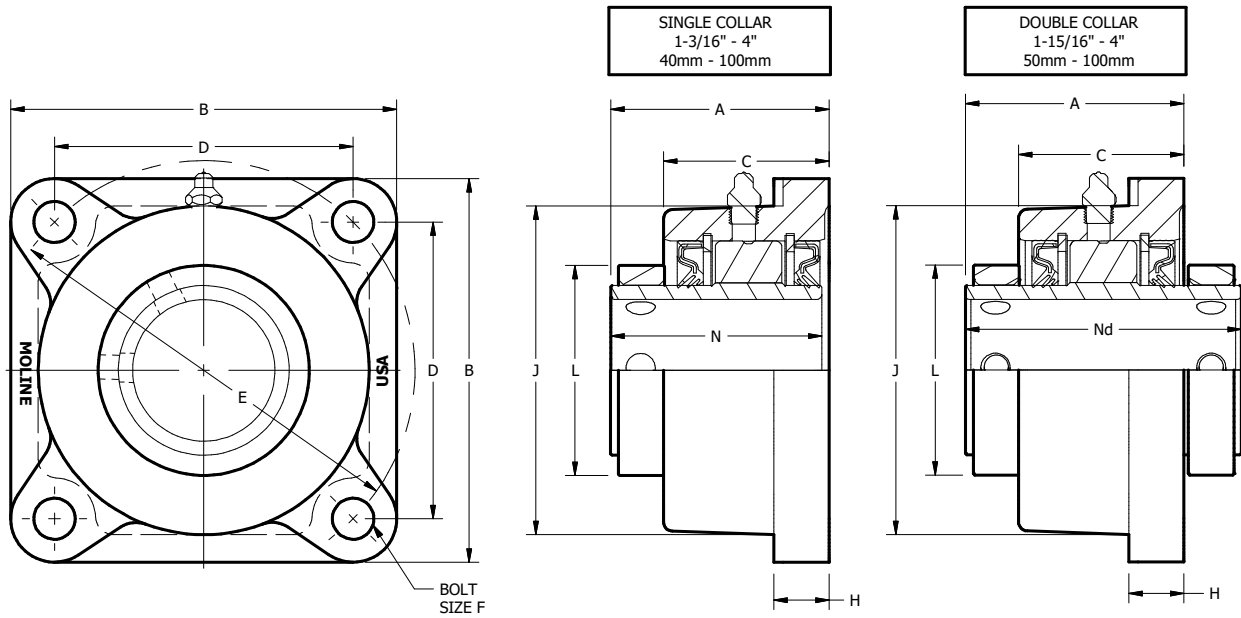

M2000
SPHERICALS

For personal service 800.242.4633
CAD drawings at no additional charge
For nomenclature see pages 240 and 241

MOLINE BEARING CO



M2000 PILOTED FLANGE CARTRIDGE, SINGLE AND DOUBLE COLLAR

SHAFT SIZE	MOLINE PART #		DIMENSIONS (INCHES)					
	EXP	NON-EXP	A	B	C	D	E	F
1 3/16	19131103	19231103	2 13/16	5 1/4	2 1/16	4 3/8	1 9/32	3/8
1 1/4	19131104	19231104						
1 7/16	19131107	19231107						
1 1/2	19131108	19231108						
1 11/16	19131111	19231111	3	6 1/8	2 3/16	5 1/8	7/8	7/16
1 3/4	19131112	19231112						
40mm	19131040	19231040						
45mm	19131045	19231045						
1 15/16	19131115	19231115	3	6 3/8	2 3/16	5 3/8	7/8	7/16
2	19131200	19231200						
50mm	19131050	19231050						
2 3/16	19131203	19231203	3 1/4	7 1/8	2 7/16	6	1	1/2
2 1/4	19131204	19231204						
55mm	19131055	19231055						
2 7/16	19131207	19231207	3 1/2	7 5/8	2 11/16	6 1/2	1	1/2
2 1/2	19131208	19231208						
60mm	19131060	19231060						
65mm	19131065	19231065						

Single Collar Assembled with SKF™ Spherical Roller Bearings. Double Collar Assembled with Timken™ Spherical Roller Bearings.

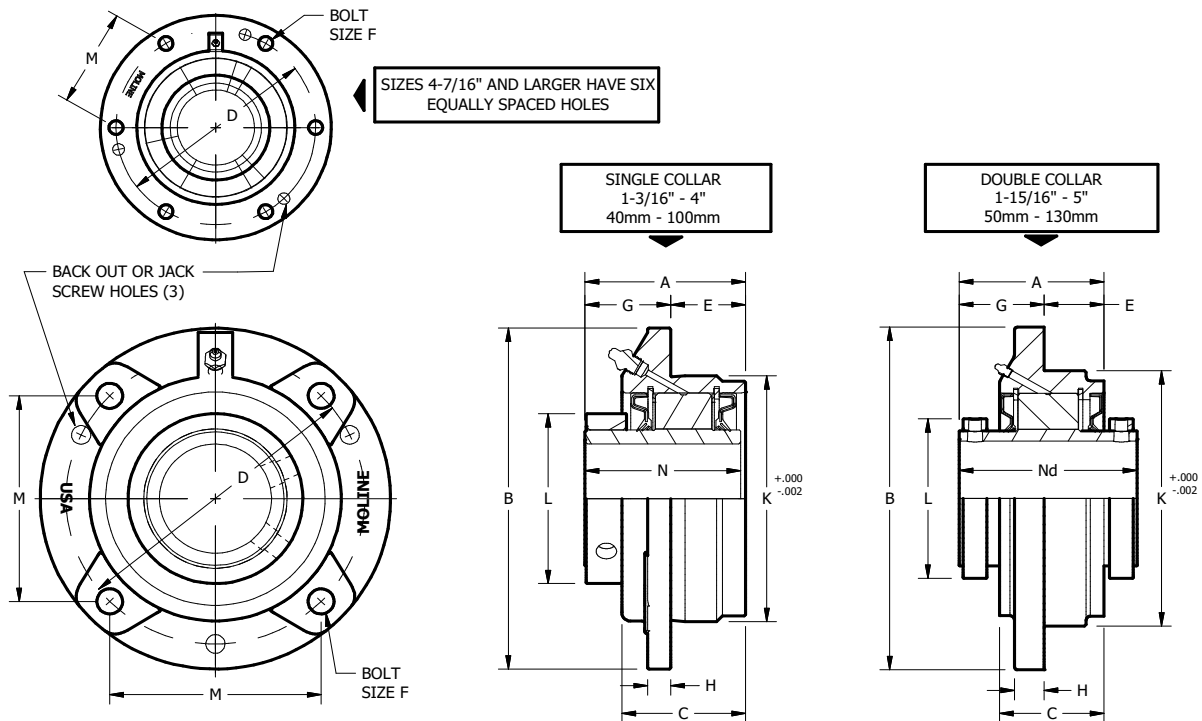

M2000 SPHERICALS

M2000 PILOTED FLANGE CARTRIDGE, SINGLE AND DOUBLE COLLAR

SHAFT SIZE	DIMENSIONS (INCHES)							WEIGHT LBS.
	G	H	K	L	M	N SINGLE	Nd DOUBLE	
1 3/16 1 1/4 1 7/16 1 1/2	1 9/16	1/2	3 5/8	2 1/2	3 3/32	2 3/4	----	7
1 11/16 1 3/4 40mm 45mm	1 9/16	1/2	4 1/4	2 5/8	3 5/8	2 7/8	----	8.5
1 15/16 2 50mm	1 1/2	1/2	4 1/2	2 7/8	3 51/64	2 7/8	3 3/4	10.5
2 3/16 2 1/4 55mm	1 25/32	1/2	5	3 1/4	4 1/4	3 1/8	4	14.5
2 7/16 2 1/2 60mm 65mm	1 7/8	5/8	5 1/2	4	4 19/32	3 3/8	4 5/16	16

Starting at Sizes 1 15/16 add Suffix "D" Suffix "D" to part number for Double Collar Spherical assembly.



M2000
SPHERICALS

For personal service 800.242.4633
CAD drawings at no additional charge
For nomenclature see pages 240 and 241

MOLINE BEARING CO



M2000 PILOTED FLANGE CARTRIDGE, SINGLE AND DOUBLE COLLAR

SHAFT SIZE	MOLINE PART #		DIMENSIONS (INCHES)					
	EXP	NON-EXP	A	B	C	D	E	F
2 1/16	19131211	19231211	3 13/16	8 3/4	2 13/16	7 1/2	1 1/4	5/8
2 3/4	19131212	19231212						
2 15/16	19131215	19231215						
3	19131300	19231300						
70mm	19131070	19231070						
75mm	19131075	19231075						
3 3/16	19131303	19231303	4 1/4	10 1/4	3 1/4	8 5/8	1 1/4	3/4
3 7/16	19131307	19231307						
3 1/2	19131308	19231308						
80mm	19131080	19231080						
85mm	19131085	19231085						
90mm	19131090	19231090						
3 11/16	19131311	19231311	4 3/4	10 7/8	3 9/16	9 3/8	1 1/2	3/4
3 15/16	19131315	19231315						
4	19131400	19231400						
100mm	19131100	19231100						
	19131100	19231100						
4 7/16	19131407	19231407	5 5/32	13 1/2	4	11 3/4	1 1/2	3/4
4 1/2	19131408	19231408						
110mm	19131110	19231110						
115mm	19131115M	19231115M						
4 15/16	19131415	19231415	6 1/16	14 3/4	5 3/4	12 3/4	1 3/4	7/8
5	19131500	19231500						
125mm	19131125	19231125						
130mm	19131130	19231130						

Single Collar Assembled with SKF™ Spherical Roller Bearings. Double Collar Assembled with Timken™ Spherical Roller Bearings.

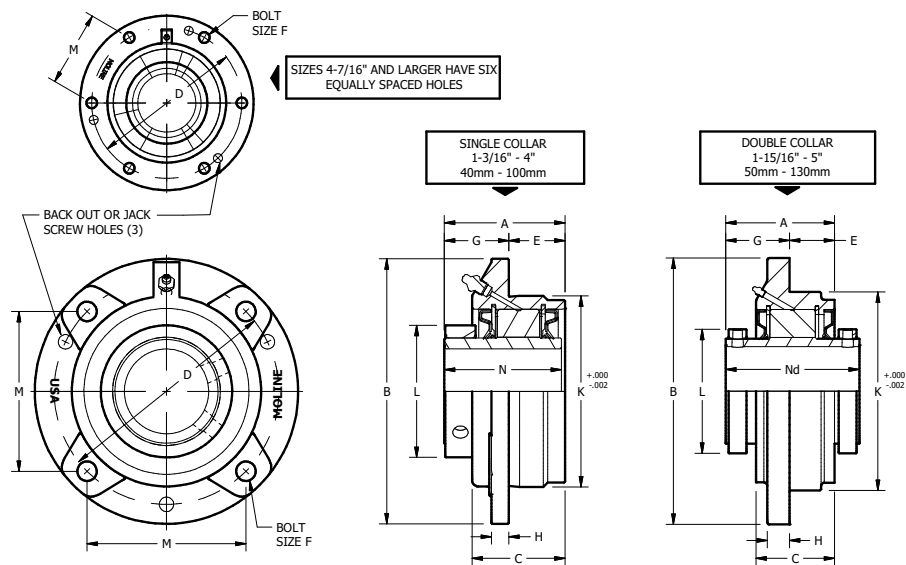

M2000 PILOTED FLANGE CARTRIDGE, SINGLE AND DOUBLE COLLAR

SHAFT SIZE	DIMENSIONS (INCHES)							WEIGHT LBS.
	G	H	K	L	M	N SINGLE	Nd DOUBLE	
2 11/16 2 3/4 2 15/16 3 70mm 75mm	2	3/4	6 3/8	4 3/8	5 19/64	3 5/8	4 3/4	22
3 3/16 3 7/16 3 1/2 80mm 85mm 90mm	2 1/2	15/16	7 3/8	5 1/8	6 3/32	4 1/32	5 3/16	33
3 11/16 3 15/16 4 100mm	2 5/8	1 1/16	8 1/8	6	6 5/8	4 19/32	5 15/16	45
4 7/16 4 1/2 110mm 115mm	3 3/16	1	10 1/4	6 1/8	5 3/32	----	6 1/4	72
4 15/16 5 125mm 130mm	3 9/16	1 1/4	11	6 7/8	5 17/32	----	7 7/16	99

M2000
SPHERICALS



For personal service 800.242.4633
CAD drawings at no additional charge
For nomenclature see pages 240 and 241

MOLINE BEARING C°



M2000 WIDE SLOT TAKE-UP, SINGLE AND DOUBLE COLLAR

SHAFT SIZE	MOLINE PART #		DIMENSIONS (INCHES)							
	EXP	NON-EXP	B	C	D	E	F	G	H	J
1 15/16	19151115	19251115								
2	19151200	19251200	6 5/16	1 1/16	3 3/4	3 15/16	1	15/16	3/4	3 5/16
50mm	19151050	19251050								
2 3/16	19151203	19251203								
2 1/4	19151204	19251204	7 1/8	1 3/16	3 3/4	4 5/8	1 1/8	1	1	3 7/8
55mm	19151055	19251055								
2 7/16	19151207	19251207								
2 1/2	19151208	19251208	7 13/16	1 1/32	4 1/2	5 1/16	1 1/2	1 1/16	1 1/4	4 1/4
60mm	19151060	19251060								
65mm	19151065	19251065								
2 11/16	19151211	19251211								
2 3/4	19151212	19251212								
2 15/16	19151215	19251215	9 1/8	1 25/32	4 3/4	5 7/8	1 1/2	1 3/8	1 1/4	4 7/8
3	19151300	19251300								
70mm	19151070	19251070								
75mm	19151075	19251075								

Starting at Sizes 1 15/16 add Suffix "D" to part number for Double Collar Spherical assembly.
Assembled with Timken™ Spherical Roller Bearings.

DOUBLE COLLAR
1-15/16" - 4"
50mm - 100mm

SINGLE COLLAR
1-15/16" - 4"
50mm - 100mm

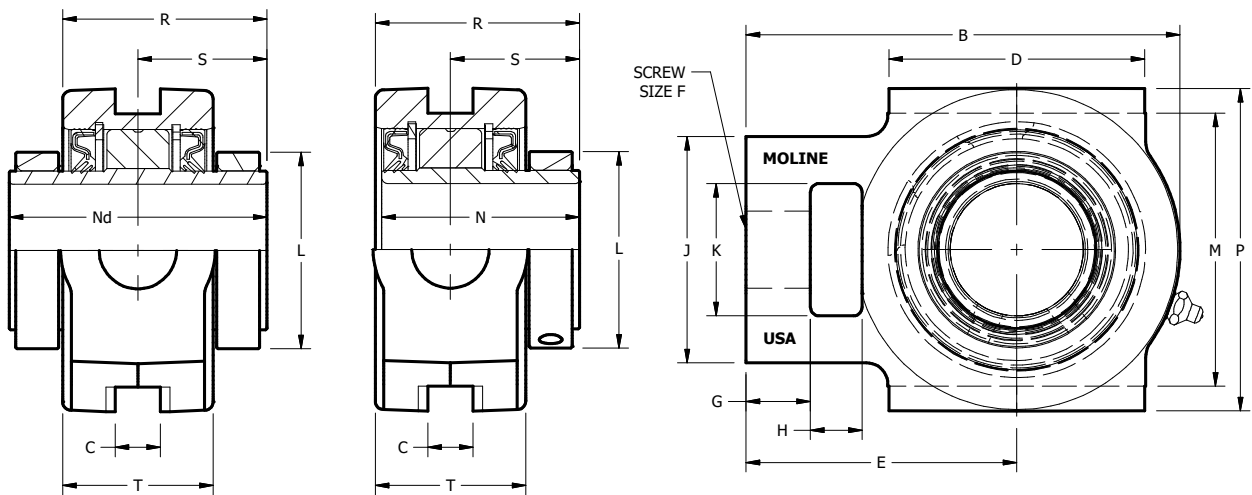

M2000
SPHERICALS

M2000 WIDE SLOT TAKE-UP, SINGLE AND DOUBLE COLLAR

SHAFT SIZE	DIMENSIONS (INCHES)									WEIGHT LBS.
	K	L	M	N SINGLE	Nd DOUBLE	P	R	S	T	
1 15/16 2 50mm	1 15/16	2 7/8	4	2 7/8	3 3/4	4 3/4	3 1/16	1 7/8	2 7/16	10
2 3/16 2 1/4 55mm	2 1/4	3 1/4	4 1/2	3 1/8	4	5 1/4	3 1/4	2	2 9/16	12
2 7/16 2 1/2 60mm 65mm	2 1/2	4	5 1/8	3 3/8	4 5/16	6	3 1/2	2 1/8	2 3/4	16
2 11/16 2 3/4 2 15/16 3 70mm 75mm	2 3/4	4 3/8	5 15/16	3 5/8	4 3/4	6 3/4	3 7/8	2 3/8	3	22



M2000 SPHERICALS

For personal service 800.242.4633
 CAD drawings at no additional charge
 For nomenclature see pages 240 and 241

MOLINE BEARING CO



M2000 WIDE SLOT TAKE-UP, SINGLE AND DOUBLE COLLAR

SHAFT SIZE	MOLINE PART #		DIMENSIONS (INCHES)							
	EXP	NON-EXP	B	C	D	E	F	G	H	J
3 3/16	19151303	19251303								
3 7/16	19151307	19251307								
3 1/2	19151308	19251308	10 1/4	1 25/32	6	6 3/8	1 3/4	1 1/16	1 5/8	4 7/8
80mm	19151080	19251080								
85mm	19151085	19251085								
90mm	19151090	19251090								
3 11/16	19151311	19251311								
3 15/16	19151315	19251315	12 9/16	2 1/16	7	8 3/8	2	2 1/16	2 1/8	6
4	19151400	19251400								
100mm	19151100	19251100								

Starting at Sizes 1 15/16 add Suffix "D" to part number for Double Collar Spherical assembly.
Assembled with Timken™ Spherical Roller Bearings.

M2000
SPHERICALS

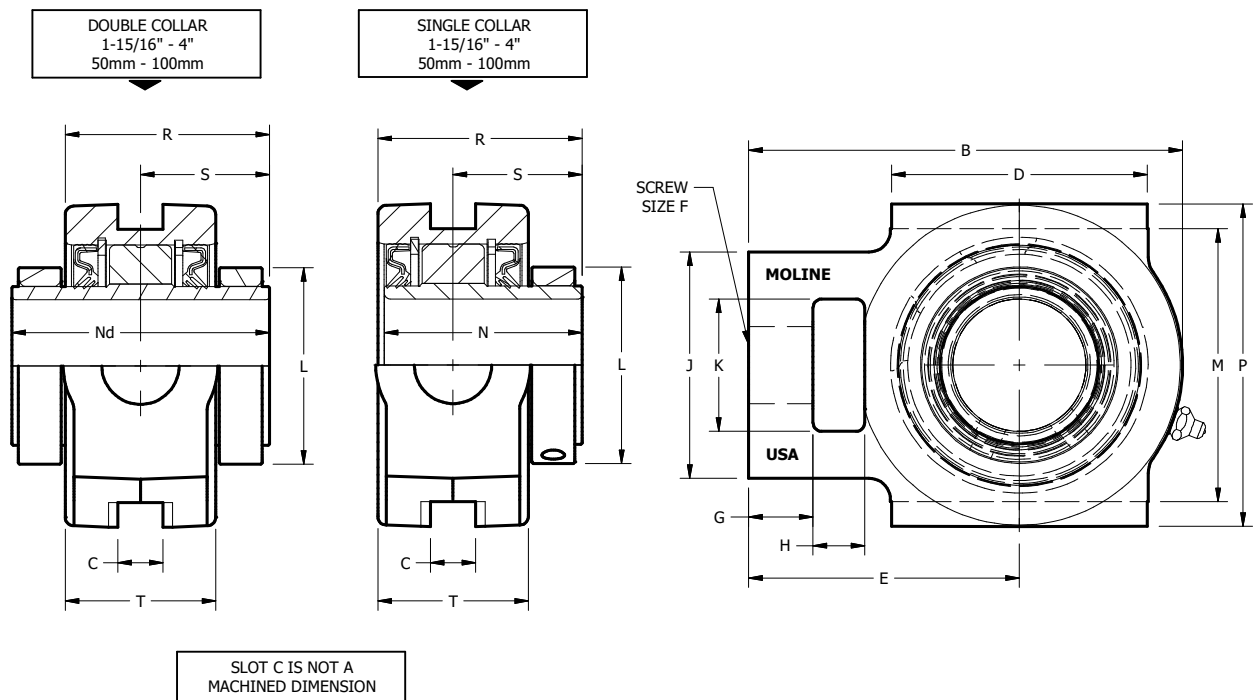

M2000 WIDE SLOT TAKE-UP, SINGLE AND DOUBLE COLLAR

SHAFT SIZE	DIMENSIONS (INCHES)									WEIGHT LBS.
	K	L	M	N SINGLE	Nd DOUBLE	P	R	S	T	
3 3/16 3 7/16 3 1/2 80mm 85mm 90mm	2 7/8	5 1/8	6 13/16	4 1/32	5 3/16	7 13/16	4 1/2	2 19/32	3 5/8	38
3 11/16 3 15/16 4 100mm	3 3/8	6 1/16	8 5/8	4 19/32	5 15/16	9 7/16	4 11/16	2 15/16	3 1/2	67



M2000 SPHERICALS

For personal service 800.242.4633
 CAD drawings at no additional charge
 For nomenclature see pages 240 and 241

MOLINE BEARING CO



M2000 APPLICATION GUIDE

At Moline, our goal is to provide you with the most reliable products, helpful service, and expert support. We work to make our application guides clear and easy to understand. But if you have further questions, please contact us. 800.242.4633

LUBRICATION - VARIOUS OPERATIONS

Normal Operation

Your Moline bearing has been greased at the factory and is ready to install and run. When establishing a re-lubrication schedule, note that a small amount of grease at frequent intervals is preferable to a large amount of grease at infrequent intervals. Table 2 below is a general guide for Lubrication. It should be noted that certain conditions may require a change of lubricating periods as dictated by experience.

High Speed Operation

At higher operating speeds, too much grease may cause overheating. In these cases, the amount of lubrication can only be determined by experience. If excess grease in the bearing causes overheating, it will be necessary to remove the grease fitting and run for 10 minutes. This will allow excess grease to escape. Then wipe off excess grease and replace the grease fitting.

Operating Temperatures

Normal temperature may range from “cool or warm to the touch” up to a point of “too hot to touch for more than a few seconds,” depending on the bearing size, speed and surrounding conditions. Abnormal bearing temperature may indicate faulty lubrication practices. Unusually high temperature accompanied by excessive leakage of grease indicates too much grease. High temperature with no grease showing at the seals, particularly if the bearing is noisy, usually indicates too little grease.

Special Operating Conditions

Refer acid, chemical, extreme or other special operating conditions to the factory.

LUBRICATION INSTRUCTIONS

Moline bearings have been lubricated at the factory with No. 2 consistency lithium base grease that is suitable for normal operating applications. Many ordinary cup greases will disintegrate at speeds far below those at which Moline bearings will operate successfully if proper grease is used. Relubricate with lithium base grease or a grease that is compatible with original lubricant and suitable for roller bearing service. It should be noted that when re-lubricating, adding a small amount of grease on a frequent basis is preferable to a large amount of grease infrequently. In unusual cases consult the factory or a reputable grease supplier.

Storage or Special Shutdown

If equipment will be idle for some time, before shutting down, add grease to the bearing, rotating the sleeve to distribute grease. If possible, cover the bearing to protect from dust and other contaminants. This will ensure protection of the bearing, particularly when exposed to severe environmental conditions. After lengthy storage, add a small amount of fresh grease before running.

M2000 SPHERICALS

TABLE 2 - LUBRICATION CHART								
HOURS RUN PER DAY	SUGGESTED LUBRICATION PERIOD IN WEEKS							
	1 TO 250 RPM	251 TO 500 RPM	501 TO 750 RPM	751 TO 1000 RPM	1001 TO 1500 RPM	1501 TO 2000 RPM	2001 TO 2500 RPM	2501 TO 3000 RPM
8	12	12	10	7	5	4	3	2
16	12	7	5	4	2	2	2	1
24	12	5	3	2	1	1	1	1

Read Operations and Lubrication sections above before establishing lubrication schedule.



M2000 APPLICATION GUIDE

Moline spherical bearings have the capacity to carry substantial radial loads, thrust loads or a combined radial and thrust load. The maximum load that can be applied is limited by the various components in the system, and the life requirements listed in this catalog. The factory should be consulted on any application that exceeds the recommendations in the catalog.

MOUNTING INSTRUCTIONS

It is critical to the performance of the bearing that it be mounted properly. Failure to follow proper mounting practice may result in reduced bearing life.

INSTALLATION INSTRUCTIONS

M2000 Non-Expansion Bearing Applications

1. Clean shaft and bore of bearing. The shaft should be straight, free of burrs and nicks, and the correct size.
2. Lubricate shaft and bearing bore with grease or oil to facilitate assembly. Slip bearing into position. When light press fit is required, press against the end of the inner ring of bearing. Do not strike or exert pressure on the housing or seals.
3. Bolt bearing to support, using shims where necessary to align bearing. Use full shims that cover the entire housing base.
4. Determine final shaft position and hand tighten screws in the locking collar(s) of non-expansion bearing firmly onto the shaft, while the other bearings remain free. If possible, rotate the shaft slowly under load to properly center the rolling elements with respect to the raceways. Tighten set screws alternately in small increments to the torque value specified in Table below. To ensure full locking of the inner race to the shaft, **after 24 hours of operation the setscrews should be retightened to the original torque value below.**

SHAFT SIZE		SET SCREW SIZE	TORQUE IN – LBS
IN	MM		
1 ³ / ₁₆ – 2 ¹ / ₄	40 – 55	3/8 – 24	290
2 ⁷ / ₁₆ – 3 ¹ / ₂	60 – 90	1/2 – 20	620
3 ¹⁵ / ₁₆ – 5	100 – 130	5/8 – 18	1325

5. Check rotation. If there is any strain, irregular rotational torque or vibration, it could be due to incorrect alignment, bent shaft or bent supports. Installation should be rechecked and correction made where necessary.

M2000 Expansion Bearing Applications

1. Clean shaft and bore of bearing. The shaft should be straight, free of burrs and nicks, and the correct size.
2. Lubricate shaft and bearing bore with grease or oil to facilitate assembly. Slip bearing into position. When light press fit is required, press against the end of the inner ring of bearing. Do not strike or exert pressure on the housing or seals.
3. Position expansion bearing in the housing. For normal expansion conditions, the bearing insert should be positioned in the center of the housing. To center bearing insert in housing, move bearing insert to extreme position (-.100" on all expansion units) and mark shaft. Then using bearing maximums total expansion table, move bearing insert in opposite direction one-half the total expansion to center bearing in the housing. If maximum expansion is required, move bearing insert to the extreme position in the housing to permit full movement in direction of expansion. After the expansion bearing has been positioned in the housing, tighten the set screws in the locking collar securely to the shaft to the recommended torque.
4. Check rotation. If there is any strain, irregular rotational torque or vibration, it could be due to incorrect alignment, bent shaft or bent supports. Installation should be rechecked and correction made where necessary.

Bearing Maximum Total Expansion

All Expansion Units have - .100" Capacity
Misalignment Capacity = +/- 1¹/₂°



M2000 APPLICATION GUIDE

Select a bearing from the M2000 load-rating chart on pages 82-83, having a radial load rating at the operating speed equal to or greater than the calculated Equivalent Radial Load for a desired L10 life. This simple method is all that is necessary for most general applications and provides for occasional shock loads.

L10 Hours of Life - Is the life that may be expected from at least 90% of a given group of bearings operated under identical conditions. The average life (L50) will be approximately five times the L10 life. To determine the L10 hours of life for loads and RPM's not listed, use the following equation.

$$L_{10} = \left(\frac{C}{P}\right)^{10/3} \times \frac{16667}{\text{RPM}}$$

Where: C= Dynamic Capacity (See Table below)
P= Equivalent Radial Load

If the load on a double row spherical bearing is only in a radial direction (no axial load), the Equivalent Radial Load (P) is equal to the actual radial load. In situations where the bearing load consists of radial and thrust loads, the total load must be converted into an Equivalent Radial Load by the equation:

$$P = XF_R + YF_A$$

Where:
FA = Axial (thrust) Load – see page 81 for maximum
FR= Radial Load
X= Radial Load Factor
(page 81)
Y= Thrust Load Factor
(page 81)

To find the X and Y values, first calculate FA/FR. Then use the M2000 Thrust Factors and Seal Speeds table on the following page to determine the appropriate values for X and Y. Substitute all known values into the Equivalent Radial Load equation.

For longer L10 hours other than 30,000 hours and not shown, multiply the Equivalent Radial Load by one of the following factors: for 20,000 L10 hours life, use a factor of .87; for 40,000 L10 hours of live, use 1.25; and for 80,000 L10 hours of live, use 1.38.

In applications that have heavy shock loads, frequent shock or severe vibrations, add up to 50% to the Equivalent Radial Load to obtain a modified Equivalent Radial Load. The amount of load added is relative to the severity of the application. Additional assistance can be obtained by consulting with the factory.

The shaft tolerances noted in the chart below are sufficient for normal applications. As noted in the following, "Thrust Factors and Seal Speeds" table on the following page 81, extremely heavy radial loads may require a light to snug press fit onto the shaft.

SHAFT SIZE		SHAFT TOLERANCES
IN	MM	
1 ³ / ₁₆ – 1 ¹ / ₂	---	Plus .0000" to minus .0005"
1 ⁵ / ₈ – 4	40 – 100	Plus .0000" to minus .0010"
4 ⁷ / ₁₆ – 5	110 – 130	Plus .0000" to minus .0015"

The magnitude and direction of both the thrust and radial load must be taken into account when selecting the housing. When pillow blocks are used, heavy loads should be directed through the base. If the bearing must be used in a situation where the load pulls the housing away from the mounting base, both the hold down bolts and housing must be of adequate strength. Auxiliary load carrying devices such as shear bars are advisable for side or end loading of pillow blocks and radial loads for flange units.



M2000 APPLICATION GUIDE

M2000 Thrust Factors and Seal Speeds

SHAFT SIZE	e	LIGHT THRUST IF FA/FR≤E		HEAVY THRUST IF FA/FR≥E		LOAD RATING		SEAL SPEED LIMITS			MAXIMUM SLIP FIT RADIAL LOAD FR**
		X	Y	X	Y	DYNAMIC C LBS.	STATIC C ₀ LBS.	CONTACT TRIPLE LIP RPM	LABYRINTH RPM	GARTER SPRING RPM	
1 3/16 – 1 1/2	.28	1.0	2.4	.67	3.6	16600	18300	2800	5300	1700	2000
1 11/16 – 1 3/4 40mm 45mm	.26	1.0	2.6	.67	3.9	17300	19800	2650	4700	1600	2100
1 15/16 – 2 50mm	.24	1.0	2.8	.67	4.2	19000	22500	2400	4250	1450	2300
2 3/16 – 2 1/4 55mm	.23	1.0	2.9	.67	4.3	22400	26500	2150	3800	1300	2700
2 7/16 – 2 1/2 60mm 65mm	.24	1.0	2.8	.67	4.2	33300	41100	1800	3250	1100	4000
2 11/16 – 3 70mm 75mm	.22	1.0	3.1	.67	4.6	35500	46800	1600	2800	950	4200
3 3/16 – 3 1/2 80mm 85mm 90mm	.23	1.0	2.9	.67	4.3	56900	76400	1300	2200	800	6800
3 11/16 – 4 100mm	.24	1.0	2.8	.67	4.2	69900	93300	1200	2000	700	8400
4 7/16 – 4 1/2 110mm 115mm	.25	1.0	2.7	.67	4.1	91700	126000	1150	1400	700	11000
4 15/16 – 5 125mm 130mm	.26	1.0	2.6	.67	3.9	123000	180000	900	1150	700	14800

* Comparing Spherical to Tapered Roller Bearings—The dynamic capacity C (Spherical) and C90 (Tapered) are not the same base. To compare basic dynamic capacities, multiply C x .259 and compare to C90.

** If load exceeds maximum allowable slip fit radial load, snug to light press fit of shaft is required.

For applications that exceed the load ratings listed above, Moline can assemble units with a higher rated spherical insert. Please contact the factory.



M2000 RADIAL LOAD RATINGS

NOMINAL SHAFT DIAMETER (IN)	L10 HRS LIFE	RADIAL LOAD RATINGS AT VARIOUS REVOLUTIONS PER MINUTE								
		50	100	200	500	1000	1200	1500	1800	2500
1 3/16	5000	7300	5930	4810	3660	2970	2780	2630	2490	2260
1 1/4	10000	5930	4810	3910	2970	2410	2260	2140	2020	1830
1 7/16	20000	4810	3910	3180	2410	1960	1830	1740	1640	1490
1 1/2	50000	3660	2970	2410	1830	1490	1390	1320	1250	1130
	100000	2970	2410	1960	1490	1210	1130	1070	1010	919
1 11/16	5000	7660	6220	5050	3840	3120	2910	2760	2610	2370
1 3/4	10000	6220	5050	4100	3120	2530	2370	2240	2120	1920
40mm	20000	5050	4100	3330	2530	2060	1920	1820	1720	1560
45mm	50000	3840	3120	2530	1920	1560	1460	1380	1310	1190
	100000	3120	2530	2060	1560	1270	1190	1120	1060	964
1 15/16	5000	7960	6470	5250	3990	3240	3030	2870	2720	-----
	10000	6470	5250	4270	3240	2630	2460	2330	2210	-----
2	20000	5250	4270	3470	2630	2140	2000	1890	1790	-----
50mm	50000	3990	3240	2630	2000	1620	1520	1440	1360	-----
	100000	3240	2630	2140	1620	1320	1230	1170	1110	-----
2 3/16	5000	9850	8000	6500	4940	4010	3750	3550	3360	-----
	10000	8000	6500	5280	4010	3260	3050	2880	2730	-----
2 1/4	20000	6500	5280	4290	3260	2650	2470	2340	2220	-----
55mm	50000	4940	4010	3260	2470	2010	1880	1780	1680	-----
	100000	4010	3260	2650	2010	1630	1530	1450	1370	-----
2 7/16	5000	14300	11600	9430	7160	5820	5440	5150	4880	-----
2 1/2	10000	11600	9430	7660	5820	4730	4420	4180	3960	-----
60mm	20000	9430	7660	6220	4730	3840	3590	3400	3220	-----
65mm	50000	7160	5820	4730	3590	2920	2730	2580	2440	-----
	100000	5820	4730	3840	2920	2370	2210	2100	1990	-----

Note: Refer to page 81 for seal speed limits.

For applications that exceed the load ratings listed above, Moline can assemble units with a higher rated spherical insert.

Please contact the factory.



M2000 RADIAL LOAD RATINGS

NOMINAL SHAFT DIAMETER (IN)	L10 HRS LIFE	RADIAL LOAD RATINGS AT VARIOUS REVOLUTIONS PER MINUTE								
		50	100	200	500	1000	1200	1500	1800	2500
2 ¹ / ₁₆	5000	15600	12600	10300	7800	6340	5930	5610	----	----
2 ³ / ₄	10000	12600	10300	8340	6340	5150	4810	4560	----	----
2 ¹⁵ / ₁₆	20000	10300	8340	6780	5150	4180	3910	3700	----	----
3	50000	7800	6340	5150	3910	3180	2970	2810	----	----
70mm	100000	6340	5150	4180	3180	2580	2410	2280	----	----
75mm										
3 ³ / ₁₆	5000	25250	20510	16660	12660	10280	9730	-----	-----	-----
3 ⁷ / ₁₆	10000	20510	16660	13530	10280	8350	7910	-----	-----	-----
3 ¹ / ₂	20000	16660	13530	10990	8350	6780	6420	-----	-----	-----
80mm	50000	12660	10280	8350	6340	5150	4880	-----	-----	-----
85mm	100000	10280	8350	6780	5150	4180	3960	-----	-----	-----
90mm										
3 ¹¹ / ₁₆	5000	31020	25200	20470	15550	12630	11960	-----	-----	-----
3 ¹⁵ / ₁₆	10000	25200	20470	16620	12630	10260	9710	-----	-----	-----
4	20000	20470	16620	13500	10260	8330	7890	-----	-----	-----
100mm	50000	15550	12630	10260	7790	6330	5990	-----	-----	-----
	100000	12630	10260	8330	6330	5140	4870	-----	-----	-----
4 ⁷ / ₁₆	5000	40700	33050	26850	20400	16570	-----	-----	-----	-----
4 ¹ / ₂	10000	33050	26850	21810	16570	13460	-----	-----	-----	-----
110mm	20000	26850	21810	17710	13460	10930	-----	-----	-----	-----
115mm	50000	20400	16570	13460	10220	8300	-----	-----	-----	-----
	100000	16570	13460	10930	8300	6740	-----	-----	-----	-----
4 ¹⁵ / ₁₆	5000	54590	44340	36010	27360	22220	-----	-----	-----	-----
5	10000	44340	36010	29250	22220	18050	-----	-----	-----	-----
125mm	20000	36010	29250	23760	18050	14660	-----	-----	-----	-----
130mm	50000	27360	22220	18050	13710	11140	-----	-----	-----	-----
	100000	22220	18050	14660	11140	9050	-----	-----	-----	-----

Note: Refer to page 81 for seal speed limits.

For applications that exceed the load ratings listed above, Moline can assemble units with a higher rated spherical insert.

Please contact the factory.

M2000 SERIES INTERCHANGE

M2000 Single Collar Interchange

PAGE	MOLINE	SKF	DODGE	LINK-BELT	REXNORD	SEALMASTER	BROWNING**	TIMKEN/QM
60	2-Bolt Pillow Block 19121 (Expansion) 19221 (Non-Expansion)	SYR SYR-H	P2BS2000RE P2BS2000R	PEB22400H PB22400H	ZAS2000 ZA2000	USRB5000E USRB5000	SPB1000E SPB1000NE	QAPL
64	4-Bolt Pillow Block 19141 (Expansion) 19241 (Non-Expansion)	----- -----	P4BS2000RE P4BS2000R	PEB22400FH PB22400FH	ZA2000F ZAS2000F	USRBF5000E USRBF5000	SPB1000FE SPB1000FNE	QAPF
68	4-Bolt Flange 19111 (Expansion) 19211 (Non-Expansion)	FYR FYR-H	F4BS2000RE* F4BS2000R*	FEB22400H FB22400H	----- ZB2000*	USFB5000 USFB5000	SFB1000E SFB1000NE	QAFL
70	Piloted Flange 19131 (Expansion) 19231 (Non-Expansion)	FYRP FYRP-H	FCS2000RE FCS2000R	----- FCB22400H	----- ZBR2000	USFC5000E USFC5000	SFC1000E SFC1000NE	QACW
74	Wide Slot Take-Up 19151 (Expansion) 19251 (Non-Expansion)	TBR TBR-H	WSTUS2000RE WSTUS2000R	----- TB22400H	----- ZT2000	USTU5000E USTU5000	STU1000E STU1000NE	QATU

M2000 Double Collar Interchange

PAGE	MOLINE	TIMKEN	REXNORD
60	2-Bolt Pillow Block 19121D (Expansion) 19221D (Non-Expansion)	QAAPL	ZAS5000 ZA5000
64	4-Bolt Pillow Block 19141D (Expansion) 19241D (Non-Expansion)	QAAPF	ZAS4000F ZA5000F
68	4-Bolt Flange 19111D (Expansion) 19211D (Non-Expansion)	QA AFL	----- -----
70	Piloted Flange 19131D (Expansion) 19231D (Non-Expansion)	QAACW	----- ZBR5000
74	Wide Slot Take-Up 19151D (Expansion) 19251D (Non-Expansion)	QAATU	----- ZT5000

* Manufactured in square and round 4-bolt flange.
Can dimensionally interchange with standard Moline M3000.

** Legacy item, has been discontinued.

This is a general dimensional interchange, for exact comparison information, please contact the factory.





ME2000™

SPHERICAL
ROLLER
BEARINGS
WITH TYPE E
DIMENSIONS

Set screws secure cone to shaft

Large diameter rollers for optimum capacity

Solid cast iron housing with center support
Made in the USA

Triple-lip contact type seals

Type E footprint with Spherical Insert

Elongated bolt holes permit adjustment and increased mounting options

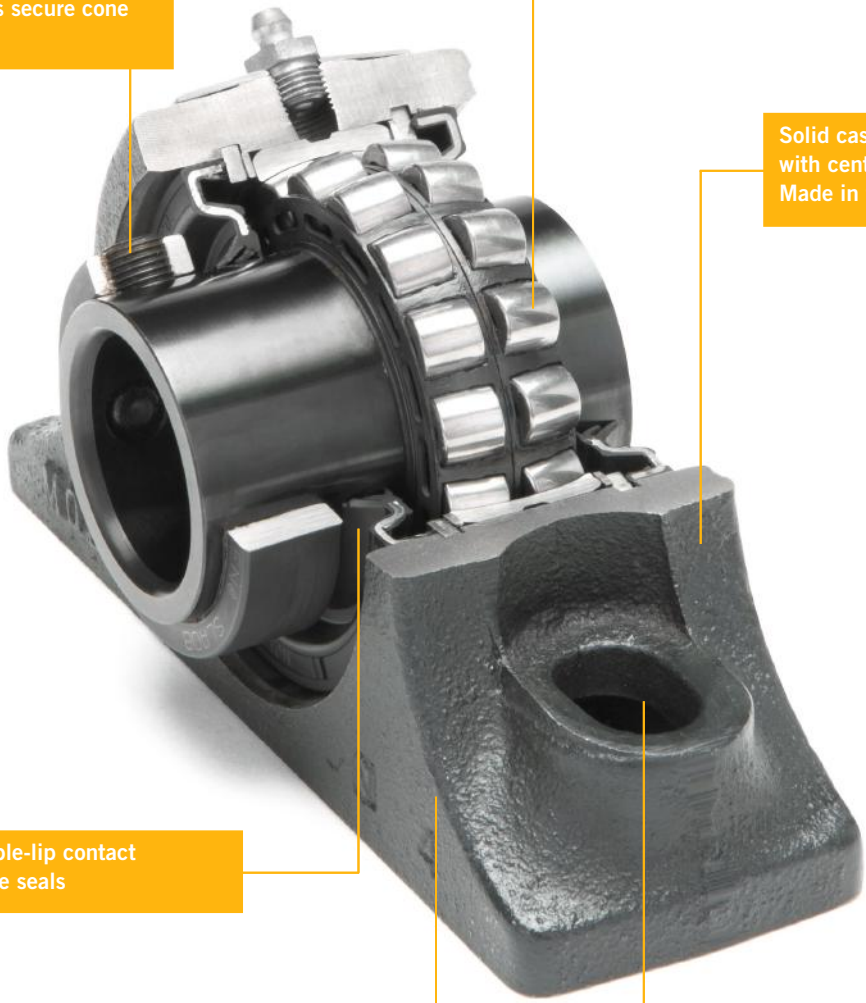

MOLINE ME2000 SPHERICAL ROLLER BEARINGS
WITH TYPE E DIMENSIONS

TIMKEN® TIMKEN INSERT INSIDE



FEATURES OF MOLINE ME2000 SPHERICAL ROLLER BEARINGS WITH TYPE E DIMENSIONS

WITH TIMKEN™ SPHERICAL ROLLER BEARINGS

- For applications that require expansion and misalignment capability and a Type E dimensional “footprint”
- Dimensionally interchangeable with competitive Spherical Roller Bearing units, Moline Split E1000, Moline ME3000
- Suggested Industry Applications: Conveying, Screening, Air Handling, Laundries, Food Processing, Paper and Forestry
- Available in shaft sizes from 1 7/16" to 5"; and 40mm to 130mm
- Assembled, adjusted and pre-lubricated in advance for immediate use
- Machined and assembled in the USA
- Built with SKF™ and Timken™ Spherical Roller Bearings
- Standard units have one Locking Collar, Double Collar Spherical (D) insert option is available in selected sizes
- +/- 1 1/2° misalignment capacity
- Available in Expansion (red tag) and Non-Expansion (yellow tag) styles
- Expansion units have .100" capacity
- Will accommodate moderate thrust loads and permits angular misalignment without loss of capacity
- Piloted Flange housings are machined with back-out holes
- Single piece outer race is grooved and has 3 lube holes for even distribution of grease
- Precision ground contours
- Rotating center guide ring for least possible friction
- Available with Standard Triple Lip Contact, Balanced Steel and Teflon Labyrinth, and Spring Loaded Garter Seals
- Timken™ Lithium Complex Grease operating temperature is up to 250°, High temperature grease is available up to 350°
- For custom lubrication, please see page 154 or contact the factory for more information
- Housings of Class 30 cast iron are made in Illinois, Iowa and Wisconsin
- Housings available in the standard painted finish. Powder coating in RAL or custom colors, Stainless Steel Powder coating, Nickel-plating, Epoxy, Teflon and other coatings are available. See page 150 or contact the factory
- Custom machining and design service are available. See page 146 or contact the factory for further information
- Made in the United States



ME2000 2-BOLT PILLOW BLOCK, SINGLE AND DOUBLE COLLAR

SHAFT SIZE	MOLINE PART #		DIMENSIONS (INCHES)														WEIGHT LBS.
	EXP	NON-EXP	A	B	C	MIN D	CENTER TO CENTER D	MAX D	F	G	H	J	L	M	N	Nd	
1 7/16	29121107	29221107	2 13/16	7 3/8	2 1/8	5	5 1/2	6	1/2	1 1/8	1 1/8	3 7/8	2 1/2	1 7/8	2 3/4	----	6.9
1 1/2	29121108	29221108	2 15/16										2 1/2		2 3/4	----	9.1
1 11/16	29121111	29221111	3 1/16	7 7/8	2 3/8	5 5/8	6 1/16	6 1/2	1/2	1 1/16	1 1/4	4 1/4	2 5/8	2 1/8	2 7/8	----	8.8
40mm	29121040	29221040															
1 3/4	29121112	29221112											2 5/8			----	11.0
45mm	29121045	29221045											2 7/8	2 1/4	2 7/8	3 3/4	10.2
1 15/16	29121115	29221115	3 1/8	8 7/8	2 7/16	6 1/8	6 11/16	7 1/4	5/8	1 5/16	1 3/8	4 1/2	2 7/8	2 1/4	2 7/8	3 3/4	10.2
2	29121200	29221200															
50mm	29121050	29221050															
2 3/16	29121203	29221203	3 5/16	9 5/8	2 5/8	6 11/16	7 3/8	8	5/8	1 7/16	1 1/2	5	3 1/4	2 1/2	3 1/8	4	11.8
55mm	29121055	29221055															
2 1/4	29121204	29221204	3 7/16										3 1/4		3 1/8		
2 7/16	29121207	29221207															
2 1/2	29121208	29221208	3 9/16	10 1/2	2 7/8	7 1/8	7 7/8	8 5/8	5/8	1 1/2	1 5/8	5 11/16	4	2 3/4	3 3/8	4 5/16	17.5
60mm	29121060	29221060															
65mm	29121065	29221065															
2 11/16	29121211	29221211															
2 3/4	29121212	29221212															
2 15/16	29121215	29221215	3 7/8	12	3	7 7/8	8 13/16	9 3/4	3/4	1 13/16	1 7/8	6 5/16	4 3/8	3 1/8	3 5/8	4 3/4	23.9
3	29121300	29221300															
70mm	29121070	29221070															
75mm	29121075	29221075															
3 3/16	29121303	29221303															
3 7/16	29121307	29221307															
3 1/2	29121308	29221308	4 7/16	14	3 5/8	9 3/4	10 5/8	11 1/2	7/8	1 7/8	2 1/4	7 1/2	5 1/8	3 3/4	4 1/32	5 3/16	34.5
80mm	29121080	29221080															
85mm	29121085	29221085															
90mm	29121090	29221090															

Starting at Sizes 1 15/16 add Suffix "D" to part number for Double Collar Spherical assembly.
Assembled with Timken™ Spherical Roller Bearings.

ME-2000™
SPHERICALS



ME2000 2-BOLT PILLOW BLOCK, SINGLE AND DOUBLE COLLAR

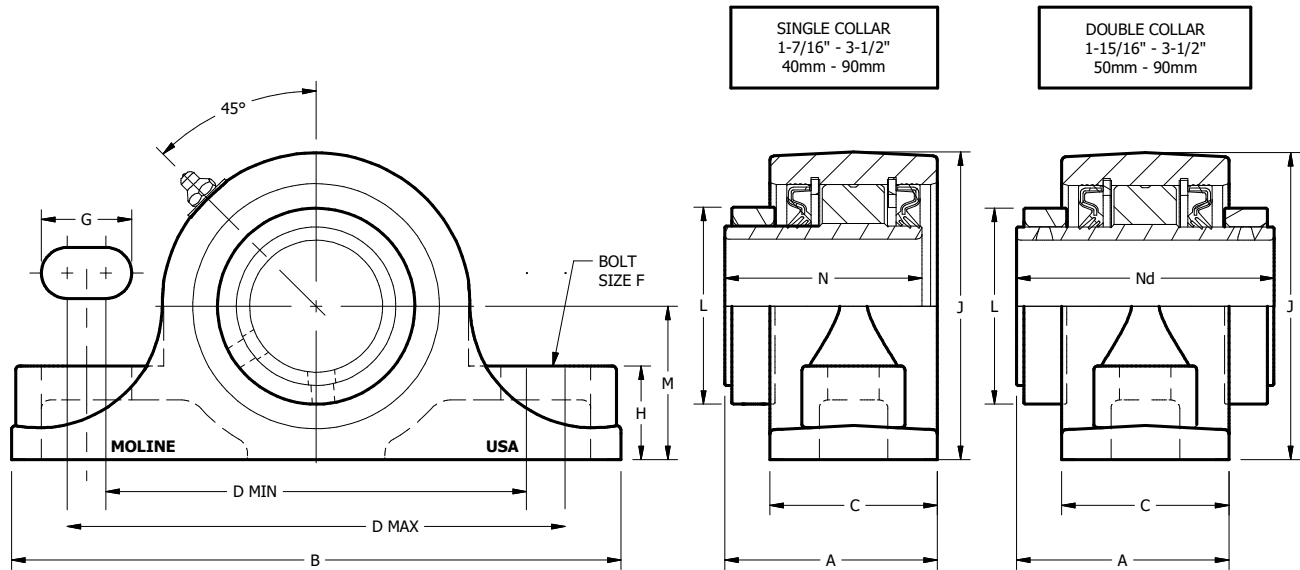

ME-2000™
SPHERICALS



ME2000 4-BOLT FLANGE, SINGLE AND DOUBLE COLLAR

SHAFT SIZE	MOLINE PART #		DIMENSIONS (INCHES)										WEIGHT LBS.
	EXP	NON-EXP	A	B	C	D	F	H	J	L	N	Nd	
1 7/16	29111107	29211107	3 1/4	4 5/8	2 19/32	3 1/2	1/2	1 1/16	3 7/8	2 1/2	2 3/4	-----	7.2
1 1/2	29111108	29211108	3 1/2							2 1/2	2 3/4	-----	12.0
1 11/16	29111111	29211111	3 9/16	5 3/8	2 31/32	4 1/8	1/2	1 3/16	4 1/4	2 5/8	2 7/8	-----	11.3
40mm	29111040	29211040											
1 3/4	29111112	29111112	3 3/4	5 5/8	3 3/32	4 3/8	1/2	1 3/16	4 1/2	2 7/8	2 7/8	3 3/4	12.6
45mm	29111045	29111045											11.9
1 15/16	29111115	29211115											
2	29111200	29211200											
50mm	29111050	29211050											
2 3/16	29111203	29211203	3 7/8	6 1/4	3 9/32	4 7/8	5/8	1 3/8	4 7/8	3 1/4	3 1/8	4	14.6
55mm	29111055	29211055											
2 1/4	29111204	29211204	4 1/8								3 1/8	4	23.5
2 7/16	29111207	29211207											
2 1/2	29111208	29211208	4 5/16	6 7/8	3 9/16	5 3/8	5/8	1 1/2	5 3/4	4	3 3/8	4 5/16	
60mm	29111060	29211060											
65mm	29111065	29211065											
2 11/16	29111211	29211211	4 3/4	7 3/4	3 15/16	6	3/4	1 5/8	6 1/2	4 3/8	3 5/8	4 3/4	31.5
2 3/4	29111212	29211212											
2 15/16	29111215	29211215											
3	29111300	29211300											
70mm	29111070	29211070											
75mm	29111075	29211075											
3 3/16	29111303	29211303	5 5/16	9 1/4	4 1/2	7	3/4	1 7/8	7 5/8	5 1/8	4 1/32	5 3/16	51.5
3 7/16	29111307	29211307											
3 1/2	29111308	29211308											
80mm	29111080	29211080											
85mm	29111085	29211085											
90mm	29111090	29211090											
3 11/16	29111311	29211311	6 9/16	10 1/4	5 5/8	7 3/4	7/8	2 1/8	8 7/16	6	4 19/32	5 15/16	64.8
3 15/16	29111315	29211315											
4	29111400	29211400											
100mm	29111100	29211100											

Starting at Sizes 1 15/16 add Suffix "D" to part number for Double Collar Spherical assembly.

Assembled with Timken™ Spherical Roller Bearings.

ME-2000™
SPHERICALS



ME2000 4-BOLT FLANGE, SINGLE AND DOUBLE COLLAR

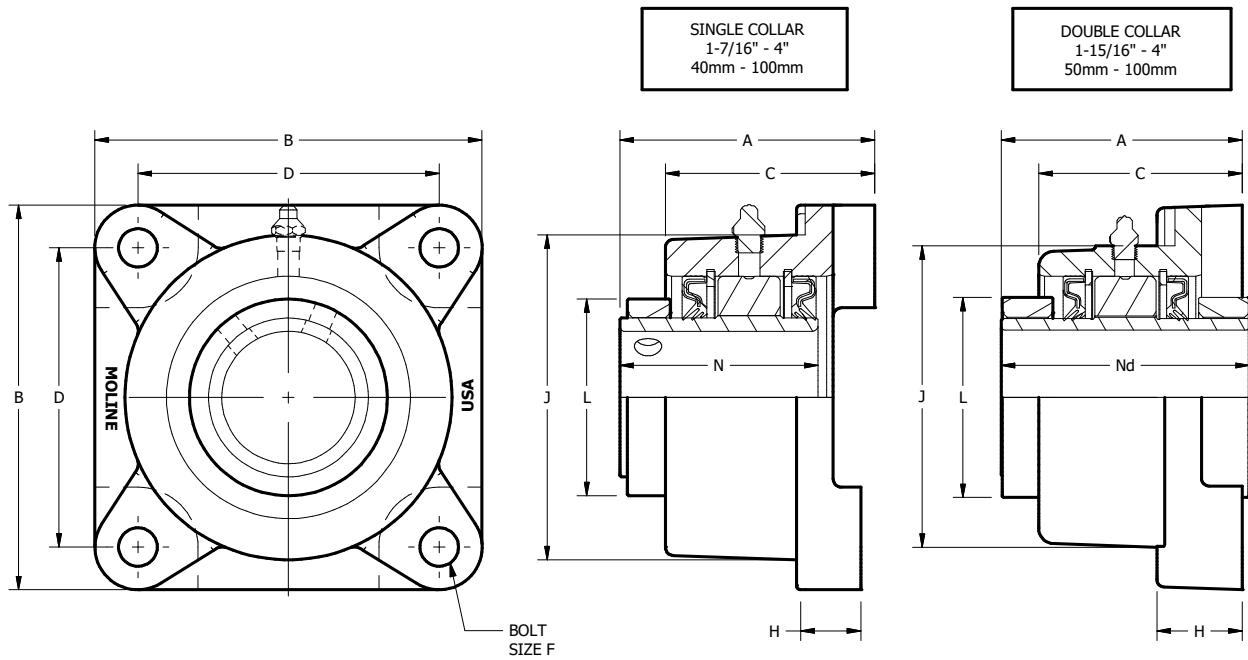

ME-2000™
SPHERICALS

For personal service 800.242.4633
CAD drawings at no additional charge
For nomenclature see pages 240 and 241

MOLINE BEARING CO.



ME2000 PILOTED FLANGE CARTRIDGE, SINGLE AND DOUBLE COLLAR

SHAFT SIZE	MOLINE PART #		DIMENSIONS (INCHES)													WT. LBS
	EXP	NON-EXP	A	B	C	D	E	F	G	H	K	L	M	N	Nd	
1 1/16 40mm	29131111 29131040	29231111 29231040	3	6 3/8	2 3/16	5 1/8	7/8	7/16	1 9/16	1/2	4 1/4	2 5/8	3 5/8	2 7/8	-----	8.5
1 15/16 2 50mm	29131115 29131200 29131050	29231115 29231200 29231050	3	6 3/8	2 3/16	5 3/8	7/8	7/16	1 1/2	1/2	4 1/2	2 7/8	3 5 1/64	2 7/8	3 3/4	10.5
2 3/16 55mm	29131203 29131055	29231203 29231055	3 1/4	7 1/8	2 7/16	6	1	1/2	1 25/32	1/2	5	3 1/4	4 1/4	3 1/8	4	14.5
2 7/16 2 1/2 60mm 65mm	29131207 29131208 29131060 29131065	29231207 29231208 29231060 29231065	3 1/2	7 5/8	2 1 1/16	6 1/2	1	1/2	1 7/8	5/8	5 1/2	4	4 19/32	3 3/8	4 5/16	16
2 1 1/16 2 3/4 2 15/16 3 70mm 75mm	29131211 29131212 29131215 29131300 29131070 29131075	29231211 29231212 29231215 29231300 29231070 29231075	3 13/16	8 3/4	2 13/16	7 1/2	1 1/4	5/8	2	3/4	6 3/8	4 3/8	5 19/64	3 5/8	4 3/4	22
3 3/16 3 7/16 3 1/2 80mm 85mm 90mm	29131303 29131307 29131308 29131080 29131085 29131090	29231303 29231307 29231308 29231080 29231085 29231090	4 1/4	10 1/4	3 1/4	8 5/8	1 1/4	3/4	2 1/2	1 5/16	7 3/8	5 1/8	6 3/32	4 1/32	4 3/16	33
3 1 1/16 3 15/16 4 100mm	29131311 29131315 29131400 29131100	29231311 29231315 29231400 29231100	4 3/4	10 7/8	3 9/16	9 3/8	1 1/2	3/4	2 5/8	1 1/16	8 1/8	6	6 5/8	4 19/32	4 15/16	45
4 7/16 4 1/2 110mm 115mm	29131407 29131408 29131110 29131115M	29231407 29231408 29231110 29231115M	5 5/32	13 1/2	4	11 3/4	1 1/2	3/4	3 3/16	1	10 1/4	6 1/8	5 3/32	-----	6 1/4	72
4 15/16 5 125mm 130mm	29131415 29131500 29131125 29131130	29231415 29231500 29231125 29231130	6 1/16	14 3/4	4 3/8	12 3/4	1 3/4	7/8	3 3/16	1 1/4	11	6 7/8	5 17/32	-----	7 7/16	99

Starting at Sizes 1-15/16 add Suffix "D" to part number for Double Collar Spherical assembly.

Assembled with Timken™ Spherical Roller Bearings.

ME-2000™
SPHERICALS



ME2000 PILOTED FLANGE CARTRIDGE, SINGLE AND DOUBLE COLLAR

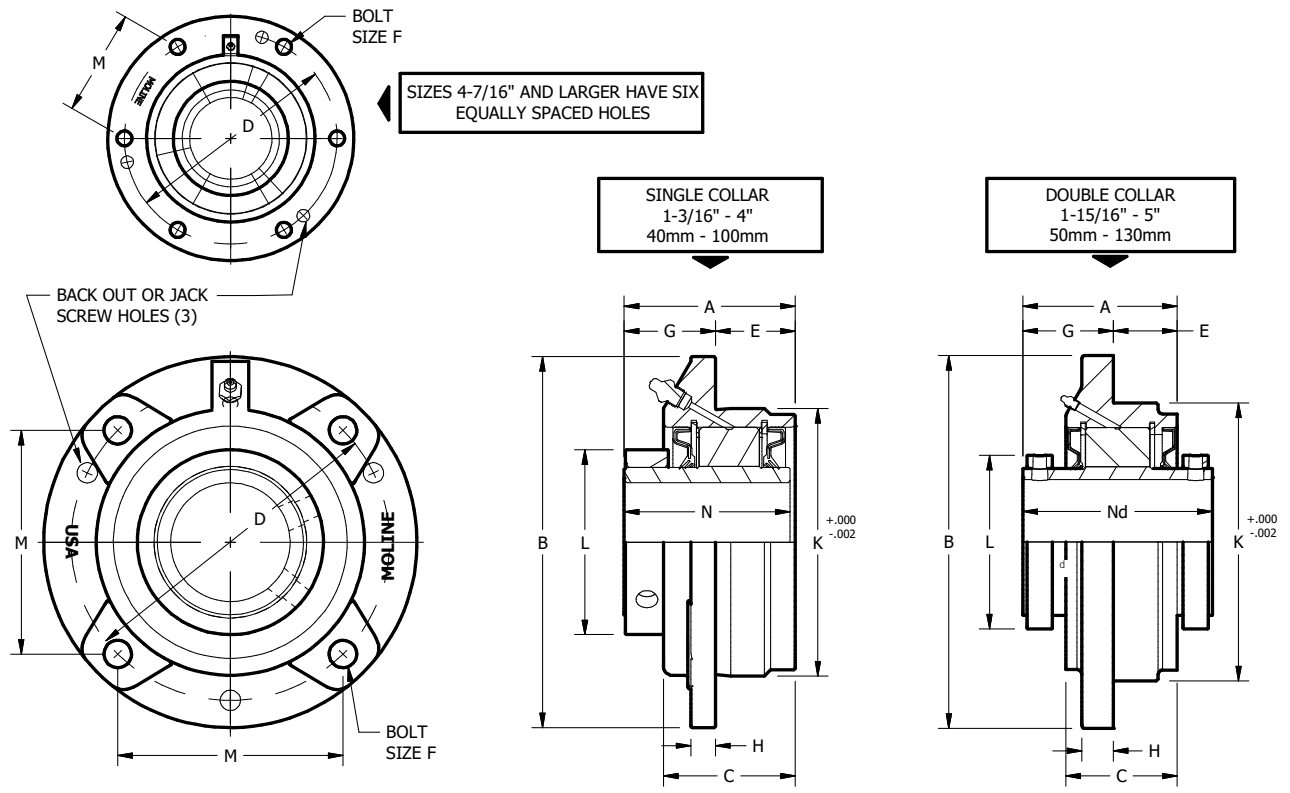

ME-2000™
SPHERICALS

For personal service 800.242.4633
CAD drawings at no additional charge
For nomenclature see pages 240 and 241

MOLINE BEARING CO



ME2000 APPLICATION GUIDE

At Moline, our goal is to provide you with the most reliable products, helpful service, and expert support. We work to make our application guides clear and easy to understand. But if you have further questions, please contact us. 800.242.4633

LUBRICATION - VARIOUS OPERATIONS

Normal Operation

Your Moline bearing has been greased at the factory and is ready to install and run. When establishing a re-lubrication schedule, note that a small amount of grease at frequent intervals is preferable to a large amount of grease at infrequent intervals. Table 2 below is a general guide for Lubrication. It should be noted that certain conditions may require a change of lubricating periods as dictated by experience.

High Speed Operation

At higher operating speeds, too much grease may cause overheating. In these cases, the amount of lubrication can only be determined by experience. If excess grease in the bearing causes overheating, it will be necessary to remove grease fitting and run for 10 minutes. This will allow excess grease to escape. Then wipe off excess grease and replace grease fitting.

Operating Temperatures

Normal temperature may range from “cool or warm to the touch” up to a point of “too hot to touch for more than a few seconds,” depending on the bearing size, speed and surrounding conditions. Abnormal bearing temperature may indicate faulty lubrication practices. Unusually high temperature accompanied by excessive leakage of grease indicates too much grease. High temperature with no grease showing at the seals, particularly if the bearing is

noisy, usually indicates too little grease. Normal temperature and a slight showing of grease at the seals indicate proper lubrication.

Special Operating Conditions

Refer acid, chemical, extreme or other special operating conditions to the factory.

LUBRICATION INSTRUCTIONS

Moline bearings have been lubricated at the factory with No. 2 consistency lithium base grease that is suitable for normal operating applications. Many ordinary cup greases will disintegrate at speeds far below those at which Moline bearings will operate successfully if proper grease is used. Relubricate with lithium base grease or a grease that is compatible with original lubricant and suitable for roller bearing service. It should be noted that when re-lubricating, adding a small amount of grease on a frequent basis is preferable to a large amount of grease infrequently. In unusual cases consult the factory or a reputable grease supplier.

Storage or Special Shutdown

If equipment will be idle for some time, before shutting down, add grease to the bearing, rotating the sleeve to distribute grease. If possible, cover the bearing to protect from dust and other contaminants. This will ensure protection of the bearing, particularly when exposed to severe environmental conditions. After lengthy storage, add a small amount of fresh grease before running.

HOURS RUN PER DAY	SUGGESTED LUBRICATION PERIOD IN WEEKS							
	1 TO 250 RPM	251 TO 500 RPM	501 TO 750 RPM	751 TO 1000 RPM	1001 TO 1500 RPM	1501 TO 2000 RPM	2001 TO 2500 RPM	2501 TO 3000 RPM
8	12	12	10	7	5	4	3	2
16	12	7	5	4	2	2	2	1
24	12	5	3	2	1	1	1	1

Read Operations and Lubrication sections above before establishing lubrication schedule.



ME2000 APPLICATION GUIDE

Moline spherical bearings have the capacity to carry substantial radial loads, thrust loads or a combined radial and thrust load. The maximum load that can be applied is limited by the various components in the system, and the life requirements listed in this catalog. The factory should be consulted on any application that exceeds the recommendations in the catalog.

MOUNTING INSTRUCTIONS

It is critical to the performance of the bearing that it be mounted properly. Failure to follow proper mounting practice may result in reduced bearing life.

INSTALLATION

ME2000 Non-Expansion Bearing Applications

1. Clean shaft and bore of bearing. The shaft should be straight, free of burrs and nicks, and the correct size.
2. Lubricate shaft and bearing bore with grease or oil to facilitate assembly. Slip bearing into position. When light press fit is required, press against the end of the inner ring of bearing. Do not strike or exert pressure on the housing or seals.
3. Bolt bearing to support, using shims where necessary to align bearing so inner ring does not rub on housing bore. Use full shims which cover across the entire housing base.
4. Determine final shaft position and hand tighten screws in the locking collar(s) of non-expansion bearing firmly onto the shaft, while the other bearings remain free. If possible, rotate the shaft slowly under load to properly center the rolling elements with respect to the raceways. Tighten set screws alternately in small increments to the torque value specified in Table below. To ensure full locking of the inner race to the shaft, **after 24 hours of operation the setscrews should be retightened to the original torque value below.**

SHAFT SIZE		SET SCREW SIZE	TORQUE IN – LBS
IN	MM		
1 ⁷ / ₁₆ – 2 ¹ / ₄	40 – 55	3 ⁸ / ₁₆ – 24	290
2 ⁷ / ₁₆ – 3 ¹ / ₂	60 – 90	1 ² / ₁₆ – 20	620
3 ¹¹ / ₁₆ – 5	100 – 130	5 ⁸ / ₁₆ – 18	1325

5. Check rotation. If there is any strain, irregular rotational torque or vibration, it could be due to incorrect alignment, bent shaft or bent supports. Installation should be rechecked and correction made where necessary.

ME2000 Expansion Bearing Applications

1. Clean shaft and bore of bearing. The shaft should be straight, free of burrs and nicks, and the correct size.
2. Lubricate shaft and bearing bore with grease or oil to facilitate assembly. Slip bearing into position. When light press fit is required, press against the end of the inner ring of bearing. Do not strike or exert pressure on the housing or seals.
3. Position expansion bearing in the housing. For normal expansion conditions, the bearing insert should be positioned in the center of the housing. To center bearing insert in housing, move bearing insert to extreme position (-.100" on all expansion units) and mark shaft. Then using bearing maximums total expansion table, move bearing insert in opposite direction one-half the total expansion to center bearing in the housing. If maximum expansion is required, move bearing insert to the extreme position in the housing to permit full movement in direction of expansion. After the expansion bearing has been positioned in the housing, tighten the set screws in the locking collar securely to the shaft to the recommended torque.
4. Check rotation. If there is any strain, irregular rotational torque or vibration, it could be due to incorrect alignment, bent shaft or bent supports. Installation should be rechecked and correction made where necessary.

Bearing Maximum Total Expansion

All Expansion Units have - .100" Capacity
Misalignment Capacity = +/- 1¹/₂°



ME2000 APPLICATION GUIDE CONTINUED

SPECIAL OPERATING CONDITIONS

Refer acid, chemical, extreme or other special operating conditions to the Moline Bearing Company.

Select a bearing from the ME2000 load-rating chart on page 100 having a radial load rating at the operating speed equal to or greater than the calculated Equivalent Radial Load for a desired L10 life. This simple method is all that is necessary for most general applications and provides for occasional shock loads.

L10 Hours of Life - Is the life that may be expected from at least 90% of a given group of bearings operated under identical conditions. The average life (L50) will be approximately five times the L10 life. To determine the L10 hours of life for loads and RPM's not listed, use the following equation.

$$L_{10} = \left(\frac{C}{P}\right)^{10/3} \times \frac{16667}{\text{RPM}}$$

Where: C= Dynamic Capacity (See Table below)
P= Equivalent Radial Load

If the load on a double row spherical bearing is only in a radial direction (no axial load), the Equivalent Radial Load (P) is equal to the actual radial load. In situations where the bearing load consists of radial and thrust loads, the total load must be converted into an Equivalent Radial Load by the equation:

$$P = XF_R + YF_A$$

Where:
FA = Axial (thrust) Load – see page 99 for maximum
FR= Radial Load
X= Radial Load Factor (page 99)
Y= Thrust Load Factor (page 99)

To find the X and Y values, first calculate FA/FR. Then use the ME2000 Thrust Factors and Seal Speeds table on the following page to determine the appropriate values for X and Y. Substitute all known values into the Equivalent Radial Load equation.

For longer L10 hours other than 30,000 hours and not shown, multiply the Equivalent Radial Load by one of the following factors: for 20,000 L10 hours life, use a factor of .87; for 40,000 L10 hours of live, use 1.25; and for 80,000 L10 hours of live, use 1.38.

In applications that have heavy shock loads, frequent shock or severe vibrations, add up to 50% to the Equivalent Radial Load to obtain a modified Equivalent Radial Load. The amount of load added is relative to the severity of the application. Additional assistance can be obtained by consulting with the factory.

The shaft tolerances noted in the chart below are sufficient for normal applications. As noted in the following, "Thrust Factors and Seal Speeds" table on the following page 99, extremely heavy radial loads may require a light to snug press fit onto the shaft.

SHAFT SIZE		SHAFT TOLERANCES
IN	MM	
1 ⁷ / ₁₆ – 1 ¹ / ₂	40 – 50	Plus .0000" to minus .0005"
1 ¹¹ / ₁₆ – 4	55 – 100	Plus .0000" to minus .0010"
4 ⁷ / ₁₆ – 5	110 – 130	Plus .0000" to minus .0015"

The magnitude and direction of both the thrust and radial load must be taken into account when selecting the housing. When pillow blocks are used, heavy loads should be directed through the base. If the bearing must be used in a situation where the load pulls the housing away from the mounting base, both the hold down bolts and housing must be of adequate strength. Auxiliary load carrying devices such as shear bars are advisable for side or end loading of pillow blocks and radial loads for flange units.



ME2000 APPLICATION GUIDE

ME2000 Thrust Factors and Seal Speeds

SHAFT SIZE	e	LIGHT THRUST IF FA/FR ≤ E		HEAVY THRUST IF FA/FR ≥ E		LOAD RATING		SEAL SPEED LIMITS			MAXIMUM SLIP FIT RADIAL LOAD FR**
		X	Y	X	Y	DYNAMIC C LBS.	STATIC C ₀ LBS.	CONTACT TRIPLE LIP RPM	LABYRINTH RPM	GARTER SPRING RPM	
1 7/16 - 1 1/2	.28	1.0	2.4	.67	3.6	16600	18300	2800	5300	1700	2000
1 11/16 - 1 3/4 40mm 45mm	.26	1.0	2.6	.67	3.9	17300	19800	2650	4700	1600	2100
1 15/16 - 2 50mm	.24	1.0	2.8	.67	4.2	19000	22500	2400	4250	1450	2300
2 3/16 - 2 1/4 55mm	.23	1.0	2.9	.67	4.3	22400	26500	2150	3800	1300	2700
2 7/16 - 2 1/2 60mm 65mm	.24	1.0	2.8	.67	4.2	33300	41100	1800	3250	1100	4000
2 11/16 - 3 70mm 75mm	.22	1.0	3.1	.67	4.6	34500	46800	1600	2800	950	4200
3 3/16 - 3 1/2 80mm 85mm 90mm	.23	1.0	2.9	.67	4.3	56900	76400	1300	2200	800	6800
3 11/16 - 4 100mm	.24	1.0	2.8	.67	4.2	69900	93300	1200	2000	700	8400
4 7/16 - 4 1/2 110mm 115mm	.25	1.0	2.7	.67	4.1	91700	126000	1150	1400	700	11000
4 15/16 - 5 125mm 130mm	.26	1.0	2.6	.67	3.9	123000	180000	900	1150	700	14800

* Comparing Spherical to Tapered Roller Bearings—The dynamic capacity C (Spherical) and C90 (Tapered) are not the same base. To compare basic dynamic capacities, multiply C x .259 and compare to C90.

** If load exceeds maximum allowable slip fit radial load, snug to light press fit of shaft is required.

For applications that exceed the load ratings above, please contact the factory for assistance.

For load requirements higher than those stated above, please contact the factory.



ME2000 RADIAL LOAD RATINGS

NOMINAL SHAFT DIAMETER (IN)	L10 HRS LIFE	RADIAL LOAD RATINGS AT VARIOUS REVOLUTIONS PER MINUTE								
		50	100	200	500	1000	1200	1500	1800	2500
1 7/16 1 1/2	5000	7300	5930	4810	3660	2970	2780	2630	2490	2260
	10000	5930	4810	3910	2970	2410	2260	2140	2020	1830
	20000	4810	3910	3180	2410	1960	1830	1740	1640	1490
	50000	3660	2970	2410	1830	1490	1390	1320	1250	1130
	100000	2970	2410	1960	1490	1210	1130	1070	1010	919
1 11/16 1 3/4 40mm 45mm	5000	7660	6220	5050	3840	3120	2910	2760	2610	2370
	10000	6220	5050	4100	3120	2530	2370	2240	2120	1920
	20000	5050	4100	3330	2530	2060	1920	1820	1720	1560
	50000	3840	3120	2530	1920	1560	1460	1380	1310	1190
	100000	3120	2530	2060	1560	1270	1190	1120	1060	964
1 15/16 2 50mm	5000	7960	6470	5250	3990	3240	3030	2870	2720	-----
	10000	6470	5250	4270	3240	2630	2460	2330	2210	-----
	20000	5250	4270	3470	2630	2140	2000	1890	1790	-----
	50000	3990	3240	2630	2000	1620	1520	1440	1360	-----
	100000	3240	2630	2140	1620	1320	1230	1170	1110	-----
2 3/16 2 1/4 55mm	5000	9850	8000	6500	4940	4010	3750	3550	3360	-----
	10000	8000	6500	5280	4010	3260	3050	2880	2730	-----
	20000	6500	5280	4290	3260	2650	2470	2340	2220	-----
	50000	4940	4010	3260	2470	2010	1880	1780	1680	-----
	100000	4010	3260	2650	2010	1630	1530	1450	1370	-----
2 7/16 2 1/2 60mm 65mm	5000	14300	11600	9430	7160	5820	5440	5150	4880	-----
	10000	11600	9430	7660	5820	4730	4420	4180	3960	-----
	20000	9430	7660	6220	4730	3840	3590	3400	3220	-----
	50000	7160	5820	4730	3590	2920	2730	2580	2440	-----
	100000	5820	4730	3840	2920	2370	2210	2100	1990	-----

Note: Refer to page 99 for seal speed limits.

For applications that exceed the load ratings above, please contact the factory for assistance.

For load requirements higher than those stated above, please contact the factory.



ME2000 RADIAL LOAD RATINGS

NOMINAL SHAFT DIAMETER (IN)	L10 HRS LIFE	RADIAL LOAD RATINGS AT VARIOUS REVOLUTIONS PER MINUTE								
		50	100	200	500	1000	1200	1500	1800	2500
2 ¹ / ₁₆	5000	15600	12600	10300	7800	6340	5930	5610	----	----
2 ³ / ₄	10000	12600	10300	8340	6340	5150	4810	4560	----	----
2 ¹⁵ / ₁₆	20000	10300	8340	6780	5150	4180	3910	3700	----	----
3	50000	7800	6340	5150	3910	3180	2970	2810	----	----
70mm	100000	6340	5150	4180	3180	2580	2410	2280	----	----
75mm										
3 ³ / ₁₆	5000	25250	20510	16660	12660	10280	9730	-----	-----	-----
3 ⁷ / ₁₆	10000	20510	16660	13530	10280	8350	7910	-----	-----	-----
3 ¹ / ₂	20000	16660	13530	10990	8350	6780	6420	-----	-----	-----
80mm	50000	12660	10280	8350	6340	5150	4880	-----	-----	-----
85mm	100000	10280	8350	6780	5150	4180	3960	-----	-----	-----
90mm										
3 ¹¹ / ₁₆	5000	31020	25200	20470	15550	12630	11960	-----	-----	-----
3 ¹⁵ / ₁₆	10000	25200	20470	16620	12630	10260	9710	-----	-----	-----
4	20000	20470	16620	13500	10260	8330	7890	-----	-----	-----
100mm	50000	15550	12630	10260	7790	6330	5990	-----	-----	-----
	100000	12630	10260	8330	6330	5140	4870	-----	-----	-----
4 ⁷ / ₁₆	5000	40700	33050	26850	20400	16570	-----	-----	-----	-----
4 ¹ / ₂	10000	33050	26850	21810	16570	13460	-----	-----	-----	-----
110mm	20000	26850	21810	17710	13460	10930	-----	-----	-----	-----
115mm	50000	20400	16570	13460	10220	8300	-----	-----	-----	-----
	100000	16570	13460	10930	8300	6740	-----	-----	-----	-----
4 ¹⁵ / ₁₆	5000	54590	44340	36010	27360	22220	-----	-----	-----	-----
5	10000	44340	36010	29250	22220	18050	-----	-----	-----	-----
125mm	20000	36010	29250	23760	18050	14660	-----	-----	-----	-----
130mm	50000	27360	22220	18050	13710	11140	-----	-----	-----	-----
	100000	22220	18050	14660	11140	9050	-----	-----	-----	-----

Note: Refer to page 99 for seal speed limits.

For applications that exceed the load ratings above, please contact the factory for assistance.



ME2000 SERIES INTERCHANGE

ME2000 Single Collar Interchange (with Type E Dimensions)

PAGE	MOLINE	SKF	REX	LINK-BELT	DODGE	SEALMASTER
90	2-Bolt Pillow Block					
	29121 (Expansion)	SYE	----	EPE-B22400H	EP2B-S2-000RE	USRBE5000E
	29221 (Non-Expansion)	SYE-H	ZEP	EP-B22400H	EP2B-S2-000R	USRBE5000
92	4-Bolt Flange					
	29111 (Expansion)	----	----	EFR-B22400H	EF4B-S2-000RE	USFBE5000E
	29211 (Non-Expansion)	----	ZEF	----	EF4B-S2-000R	USFBE5000
94	Piloted Flange					
	29131 (Expansion)	----	----	----	----	USFCE5000E
	29231 (Non-Expansion)	----	----	FCB22400H	----	USFCE5000

Moline ME2000 can be dimensionally interchanged with the Moline Type E, E1000 and ME3000.

ME2000 Double Collar Interchange (with Type E Dimensions)

PAGE	MOLINE	LINK BELT
90	2-Bolt Pillow Block	
	19121D (Expansion)	EPEB22500
	19221D (Non-Expansion)	EPB22500
92	4-Bolt Flange	
	19111D (Expansion)	----
	19211D (Non-Expansion)	EFB22500
94	Piloted Flange	
	19131D (Expansion)	----
	19231D (Non-Expansion)	----

Starting at Sizes 1 ¹⁵/₁₆ add Suffix "D" to part number for Double Collar Spherical.

Assembled with Timken™ Spherical Roller Bearings.

Moline ME2000D can dimensionally interchange with standard Moline Type E, E1000 and ME3000.

This is a general dimensional interchange, for exact comparison information, please contact the factory.

For Nomenclature see pages 240-241.





M3000

EVEN-LOK™

SPHERICAL

ROLLER

BEARINGS

An increasingly popular addition to the Moline line, is the M3000 Even-Lok™ mounted spherical bearing using a built-in mechanical connector that applies a near 360° concentric grip and almost a 100% interface with the surface of the shaft.

This unique locking mechanism helps eliminate vibration and slippage between the mating surfaces.

An excellent choice for screening and conveying, material and air handling, or industrial laundry applications, where there are problems with fretting corrosion, slippage on the shaft, or vibration, Moline's M3000 Even-Lok™ spherical roller bearing will help.

Moline M3000 units require less time and skill to install, saving your maintenance on costly down time and expense.

The M3000 2-Bolt and 4-Bolt Pillow Blocks, 4-Bolt Flange Bearings, Piloted Flange Bearings and Wide Slot Take-up Bearings are ready to slip onto the shaft when received because they are completely assembled, adjusted, sealed and pre-lubricated at the factory. The self-aligning feature provides for speedy mounting with a minimum of field adjustment required. The housings are ruggedly designed and made in the USA of Class 30 cast iron.

The M3000 Even-Lok™ comes with mounting instructions and an Hex-L Key Allen wrench for easy mounting and dismounting.

Our M3000 bearings are comparable to other adapter mounted spherical roller bearings, and are equipped with the SKF Explorer™ Spherical Roller Bearing Insert.

Moline M3000 bearings are available in expansion and non-expansion styles. The expansion units have the capacity to move up to .100". The bearings are available in shaft sizes from 1⁷/₁₆" up to 4".

All Moline housings come with a standard paint finish. Custom Colors, Powder Coating, Stainless Powder coating, Nickel plating, Epoxy and Teflon coatings will be quoted on request. Special machining is also available, please call us at the factory for further information.

Moline M3000 Even-Lok™ Spherical Roller Bearings are carried in Moline warehouses and distributor stocks throughout the United States and in Canada.

Solid cast iron housing,
with center support
Made in the USA

Even-Lok™ bearing provides
near 360°/100%
interface with shaft

Large diameter rollers for
optimum capacity

Readily accessible
mounting screws for
easy installation

Sealed, pre-lubricated
bearing eliminates
most environmental
contamination

Elongated bolt holes
permit adjustment and
increased mounting
options

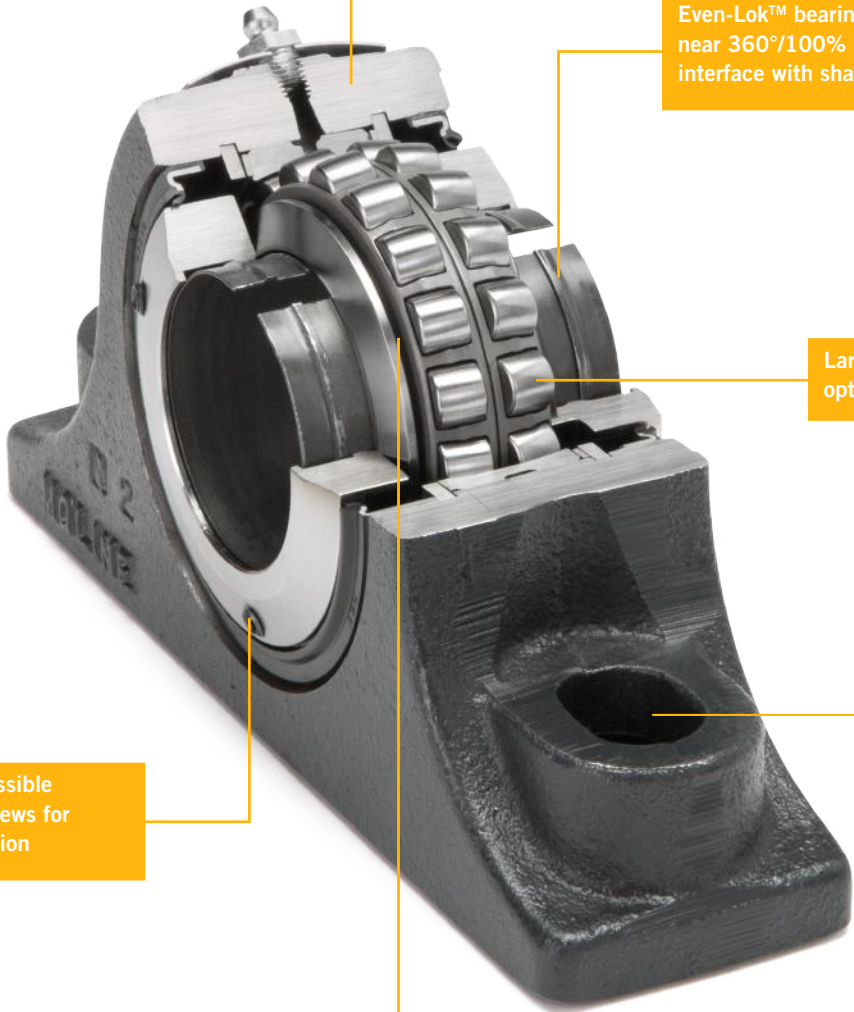

FEATURES OF MOLINE M3000 EVEN-LOK™ SPHERICAL ROLLER BEARINGS

WITH SKF® ROLLER BEARINGS

- For applications that require expansion and misalignment capability, or where vibration, slippage or fretting corrosion is present
- Dimensionally interchangeable with comparable competitive Spherical Roller Bearing units and Moline M2000
- Suggested Industry Applications: Conveying, Screening, Air Handling, Industrial Laundries, High Speed Fans
- Available in shaft sizes from 1 7/16" to 4"
- Assembled, adjusted and pre-lubricated in advance for immediate use
- Built with SKF™ Explorer Spherical Roller Bearings
- Supplies near 360° locking around, and near 100% interface with the shaft that eliminates slippage due to vibration
- Supplied with special Hex-L Key Allen wrench for easy mounting and dismounting
- +/- 1 1/2° misalignment capacity
- Available in Expansion (red tag) and Non-Expansion (yellow tag) styles
- Expansion units have .100" capacity
- Compared to traditional set screw locking, concentric locking reduces fretting corrosion
- Distributes locking force equally through Even-Lok™, reducing the risk of particle infiltration in the inner sleeve
- Available with Standard Double Lip Contact Seal made by SKF® or Balanced Steel Labyrinth Seals
- Timken™ Lithium Complex Grease operating temperature is up to 250°, High temperature grease is available up to 350°
- For custom lubrication, please see page 154 or contact the factory for more information
- Housings of Class 30 cast iron are made in Illinois, Iowa and Wisconsin
- Housings available in the standard painted finish. Powder coating in RAL or custom colors, Stainless Steel Powder coating, Nickel-plating, Epoxy, Teflon and other coatings are available. See page 150 or contact the factory
- Custom machining and design service are available. See page 146 or contact the factory for further information
- Made in the United States

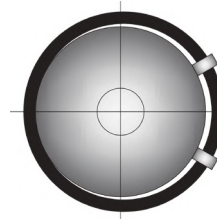

Traditional Set
Screw Locking

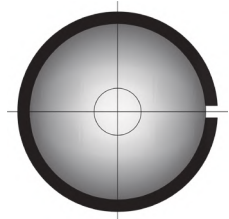

M3000 Even-Lok™

Standard Double Lip Contact Seal made by SKF®



Balanced Steel Labyrinth Seal for high speed and high temp applications



M3000 EVEN-LOK™ 2-BOLT PILLOW BLOCK

SHAFT SIZE	MOLINE PART #		DIMENSIONS (INCHES)											WEIGHT LBS.
	EXP	NON-EXP	A	B	C	MIN D	CENTER TO CENTER D	MAX D	F	G	H	J	M	
1 ⁷ / ₁₆ 1 ¹ / ₂	19621107 19621108	19721107 19721108	2 ⁹ / ₁₆	6 ⁷ / ₈	2 ³ / ₁₆	4 ¹¹ / ₁₆	5	5 ⁵ / ₁₆	1/2	1 ⁵ / ₁₆	1 ³ / ₁₆	3 ⁷ / ₈	1 ⁷ / ₈	6.9
1 ¹¹ / ₁₆ 1 ³ / ₄	19621111 19621112	19721111 19721112	2 ⁹ / ₁₆	7 ³ / ₈	2 ³ / ₁₆	5 ³ / ₁₆	5 ¹ / ₂	5 ¹³ / ₁₆	1/2	1 ⁵ / ₁₆	1 ⁵ / ₁₆	4 ¹ / ₄	2 ¹ / ₈	8.1
1 ¹⁵ / ₁₆ 2	19621115 19621200	19721115 19721200	2 ⁹ / ₁₆	8 ³ / ₈	2 ³ / ₁₆	5 ¹⁵ / ₁₆	6 ¹ / ₄	6 ⁹ / ₁₆	5/8	1	1 ³ / ₈	4 ⁹ / ₁₆	2 ¹ / ₄	9.1
2 ³ / ₁₆	19621203	19721203	2 ¹⁹ / ₃₂	8 ⁷ / ₈	2 ¹ / ₂	6 ⁷ / ₁₆	6 ³ / ₄	7 ¹ / ₁₆	5/8	1	1 ⁵ / ₈	5	2 ¹ / ₂	11.8
2 ⁷ / ₁₆ 2 ¹ / ₂	19621207 19621208	19721207 19721208	2 ¹³ / ₁₆	9 ¹ / ₄	2 ³ / ₄	6 ¹³ / ₁₆	7 ¹ / ₈	7 ⁷ / ₁₆	5/8	1	1 ³ / ₄	5 ¹¹ / ₁₆	2 ³ / ₄	16.2
2 ¹¹ / ₁₆ 2 ³ / ₄ 2 ¹⁵ / ₁₆ 3	19621211 19621212 19621215 19621300	19721211 19721212 19721215 19721300	2 ¹³ / ₁₆	10 ¹ / ₂	2 ¹³ / ₁₆	7 ¹³ / ₁₆	8 ¹ / ₈	8 ⁷ / ₁₆	3/4	1 ¹ / ₈	2 ¹ / ₄	6 ⁷ / ₁₆	3 ¹ / ₄	22.1
3 ⁷ / ₁₆ 3 ¹ / ₂	19621307 19621308	19721307 19721308	3 ²⁵ / ₆₄	13	3 ¹ / ₄	9 ¹ / ₂	10	10 ¹ / ₂	7/8	1 ⁷ / ₁₆	2 ¹ / ₄	7 ¹ / ₂	3 ³ / ₄	31.6
3 ¹⁵ / ₁₆ 4	19621315 19621400	19721315 19721400	3 ³¹ / ₆₄	14 ¹ / ₂	3 ⁹ / ₁₆	10	10 ⁷ / ₈	11 ³ / ₄	1	1 ¹⁵ / ₁₆	2 ¹ / ₂	8 ³ / ₈	4 ¹ / ₈	45

Refer to Mounting and Dismounting Instructions on pages 121 and 122.



M3000 EVEN-LOK™ 2-BOLT PILLOW BLOCK

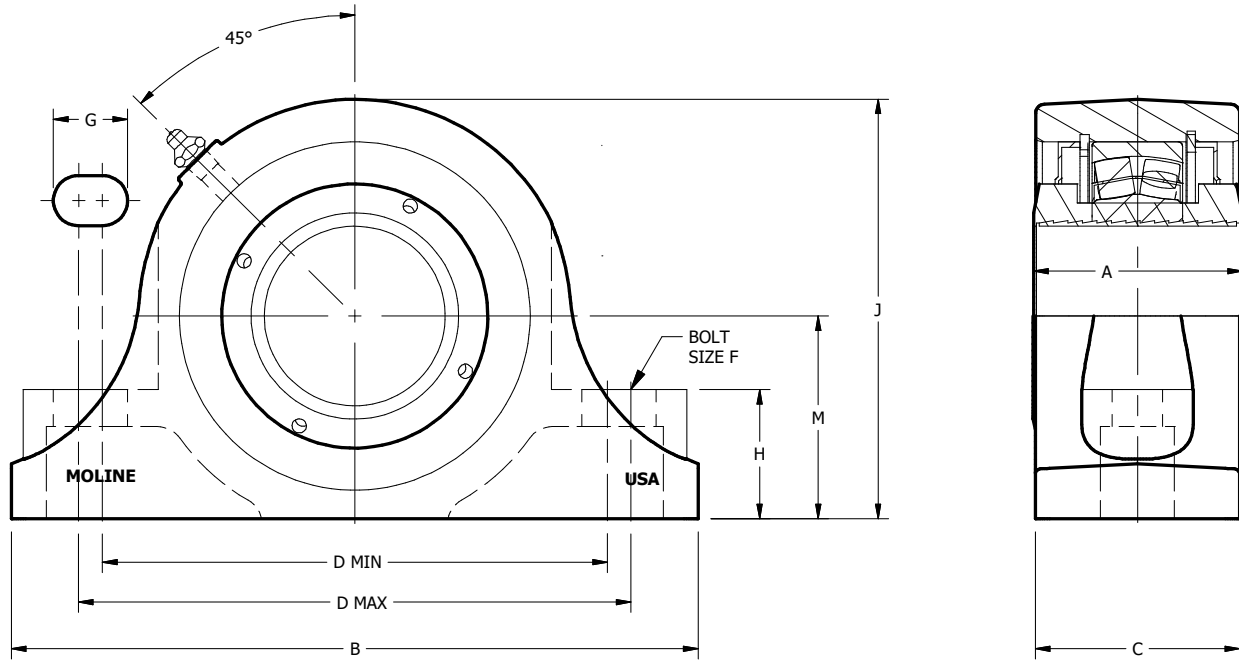

For personal service 800.242.4633
 CAD drawings at no additional charge
 For nomenclature see pages 240 and 241

MOLINE BEARING CO



M3000 EVEN-LOK™ 4-BOLT PILLOW BLOCK

SHAFT SIZE	MOLINE PART #		DIMENSIONS (INCHES)											WT. LBS.	
	EXP	NON-EXP	A	B	C	MIN D	CENTER TO CENTER D	MAX D	E	F	G	H	J		M
2 7/16 2 1/2	19641207 19641208	19741207 19741208	2 13/16	9 1/4	3 3/4	6 7/8	7 1/4	7 5/8	1 3/4	1/2	15/16	1 3/4	5 11/16	2 3/4	17
2 11/16 2 3/4 2 15/16 3	19641211 19641212 19641215 19641300	19741211 19741212 19741215 19741300	2 13/16	10 1/2	3 3/4	7 7/8	8 1/8	8 3/8	1 7/8	5/8	15/16	2 1/4	6 7/16	3 1/4	26
3 7/16 3 1/2	19641307 19641308	19741307 19741308	3 25/64	13	3 7/8	9 1/4	10	10 3/4	2	3/4	1 9/16	2 1/4	7 1/2	3 3/4	38
3 15/16 4	19641315 19641400	19741315 19741400	3 31/64	15 1/4	4 1/2	11	12	13	2 1/4	3/4	1 13/16	2 5/8	8 1/2	4 1/4	50

Refer to Mounting and Dismounting Instructions on pages 121 and 122.



M3000 EVEN-LOK™ 4-BOLT PILLOW BLOCK

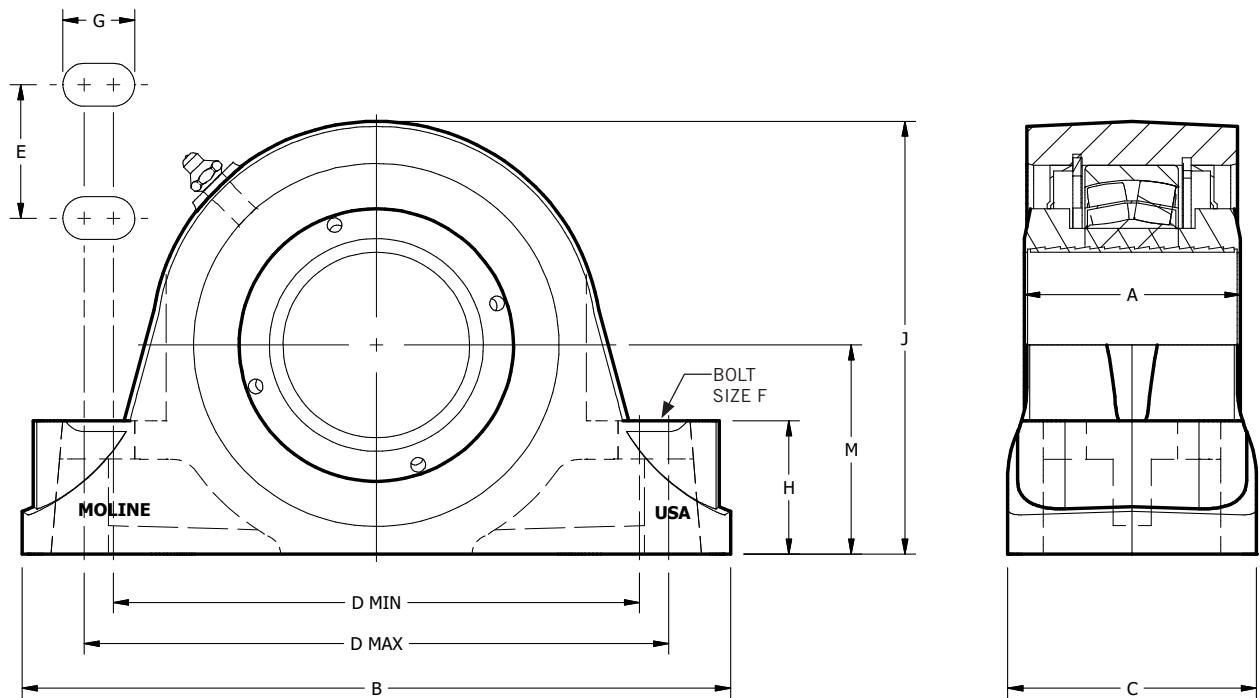

For personal service 800.242.4633
 CAD drawings at no additional charge
 For nomenclature see pages 240 and 241

MOLINE BEARING CO



M3000 EVEN-LOK™ 4-BOLT FLANGE

SHAFT SIZE	MOLINE PART #		DIMENSIONS (INCHES)									P MAX	WEIGHT LBS.
	EXP	NON-EXP	A	B	C	D	E	F	H	J	L*		
1 ⁷ / ₁₆ 1 ¹ / ₂	19611107 19611108	19711107 19711108	2 ⁹ / ₁₆	4 ⁵ / ₈	2 ¹ / ₄	3 ¹⁷ / ₃₂	5	¹ / ₂	³ / ₄	3 ⁷ / ₈	2 ⁵ / ₈	.23	7
1 ¹¹ / ₁₆ 1 ³ / ₄	19611111 19611112	19711111 19711112	2 ⁹ / ₁₆	5	2 ¹ / ₄	3 ⁵⁷ / ₆₄	5 ¹ / ₂	¹ / ₂	³ / ₄	4 ¹ / ₄	2 ¹³ / ₁₆	.13	10
1 ¹⁵ / ₁₆ 2	19611115 19611200	19711115 19711200	2 ⁹ / ₁₆	5 ¹ / ₄	2 ¹ / ₄	4 ¹ / ₁₆	5 ³ / ₄	¹ / ₂	³ / ₄	4 ¹ / ₂	3	.23	10.5
2 ³ / ₁₆	19611203	19711203	2 ¹⁹ / ₃₂	5 ⁷ / ₈	2 ⁷ / ₁₆	4 ¹ / ₂	6 ³ / ₈	⁵ / ₈	³ / ₄	5	3 ³ / ₁₆	.06	12.5
2 ⁷ / ₁₆ 2 ¹ / ₂	19611207 19611208	19711207 19711208	2 ¹³ / ₁₆	6 ¹ / ₈	2 ³ / ₄	4 ²⁵ / ₃₂	6 ³ / ₄	⁵ / ₈	1	5 ³ / ₄	3 ⁵ / ₈	.02	16.5
2 ¹¹ / ₁₆ 2 ³ / ₄ 2 ¹⁵ / ₁₆ 3	19611211 19611212 19611215 19611300	19711211 19711212 19711215 19711300	2 ¹³ / ₁₆	7 ¹ / ₄	2 ⁷ / ₈	5 ⁹ / ₁₆	7 ⁷ / ₈	³ / ₄	1	6 ⁵ / ₈	4	0	25
3 ⁷ / ₁₆ 3 ¹ / ₂	19611307 19611308	19711307 19711308	3 ²⁵ / ₆₄	8 ³ / ₈	3 ¹ / ₄	6 ²³ / ₃₂	9 ¹ / ₂	³ / ₄	1 ¹ / ₈	7 ⁵ / ₈	4 ³ / ₄	.02	35
3 ¹⁵ / ₁₆ 4	19611315 19611400	19711315 19711400	3 ³¹ / ₆₄	9 ¹ / ₂	3 ⁹ / ₁₆	7 ¹⁹ / ₃₂	10 ³ / ₄	⁷ / ₈	1 ³ / ₁₆	8 ³ / ₈	5 ¹ / ₈	0	48

Refer to Mounting and Dismounting Instructions on pages 121 and 122.

* In some cases the bearing insert protrudes past the base of the housing (P Max). Clearance for drive collar "L" is required.



M3000 EVEN-LOK™ 4-BOLT FLANGE

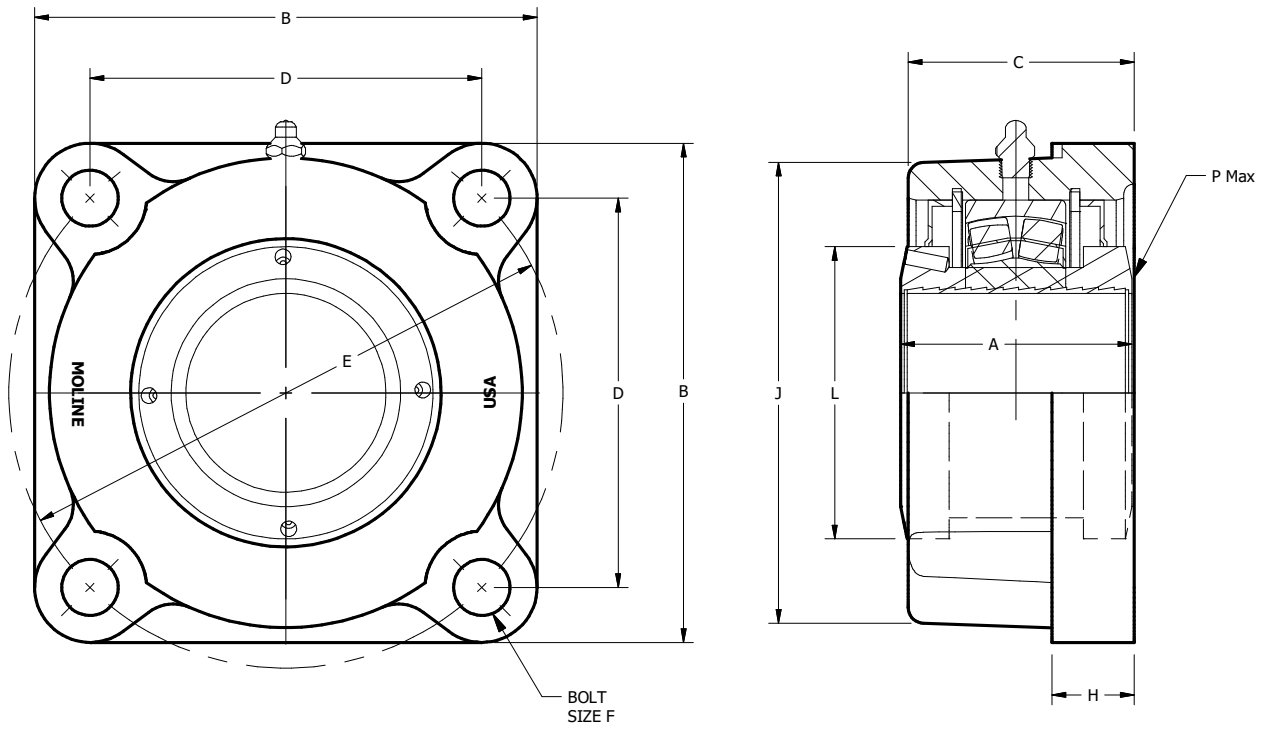

For personal service 800.242.4633
 CAD drawings at no additional charge
 For nomenclature see pages 240 and 241

MOLINE BEARING CO.



M3000 EVEN-LOK™ PILOTED FLANGE CARTRIDGE

SHAFT SIZE	MOLINE PART #		DIMENSIONS (INCHES)										WEIGHT LBS.
	EXP	NON-EXP	A	B	C	D	E	F	G	H	K	M	
1 7/16 1 1/2	19631107 19631108	19731107 19731108	2 9/16	5 1/4	2 1/16	4 3/8	1 9/32	3/8	1 3/16	1/2	3 5/8	3 3/32	7
1 11/16 1 3/4	19631111 19631112	19731111 19731112	2 9/16	6 1/8	2 3/16	5 1/8	7/8	7/16	3/4	1/2	4 1/4	3 5/8	8.5
1 15/16 2	19631115 19631200	19731115 19731200	2 9/16	6 3/8	2 3/16	5 3/8	7/8	7/16	1 1/16	1/2	4 1/2	3 51/64	10.5
2 3/16	19631203	19731203	2 19/32	7 1/8	2 7/16	6	1	1/2	15/16	1/2	5	4 1/4	14.5
2 7/16 2 1/2	19631207 19631208	19731207 19731208	2 13/16	7 5/8	2 11/16	6 1/2	1	1/2	1 1/16	5/8	5 1/2	4 19/32	16
2 11/16 2 3/4 2 15/16 3	19631211 19631212 19631215 19631300	19731211 19731212 19731215 19731300	2 13/16	8 3/4	2 13/16	7 1/2	1 1/4	5/8	1	3/4	6 3/8	5 19/64	22
3 7/16 3 1/2	19631307 19631308	19731307 19731308	3 25/64	10 1/4	3 1/4	8 5/8	1 1/4	3/4	1 1/2	15/16	7 3/8	6 3/32	33
3 15/16 4	19631315 19631400	19731315 19731400	3 31/64	10 7/8	3 9/16	9 3/8	1 1/2	3/4	1 7/16	1 1/16	8 1/8	6 5/8	45

Refer to Mounting and Dismounting Instructions on pages 121 and 122.



M3000 EVEN-LOK™ PILOTED FLANGE CARTRIDGE

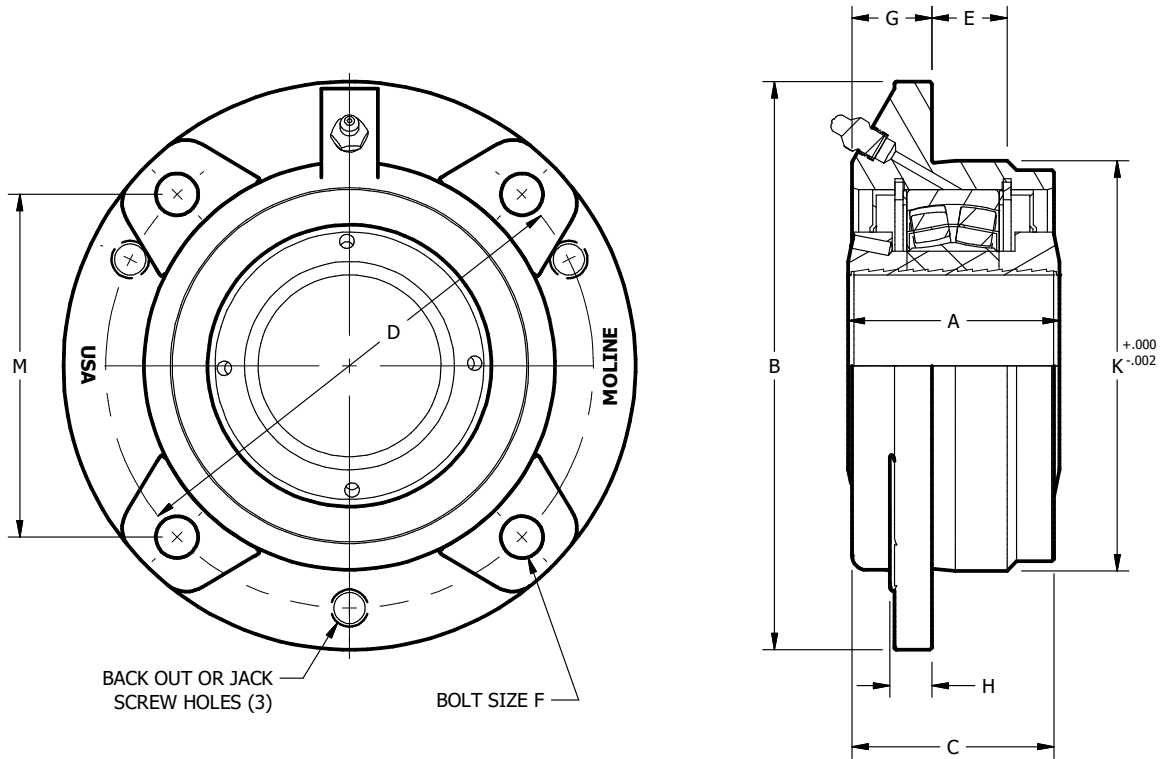

For personal service 800.242.4633
 CAD drawings at no additional charge
 For nomenclature see pages 240 and 241

MOLINE BEARING CO.



M3000 EVEN-LOK™ WIDE SLOT TAKE-UP

SHAFT SIZE	MOLINE PART #		DIMENSIONS (INCHES)				
	EXP	NON-EXP	A	B	C	D	E
1 ¹⁵ / ₁₆ 2	19651115 19651200	19751115 19751200	2 ⁹ / ₁₆	6 ⁵ / ₁₆	1 ¹ / ₁₆	3 ³ / ₄	3 ¹⁵ / ₁₆
2 ³ / ₁₆	19651203	19751203	2 ¹⁹ / ₃₂	7 ¹ / ₈	1 ³ / ₁₆	3 ³ / ₄	4 ⁵ / ₈
2 ⁷ / ₁₆ 2 ¹ / ₂	19651207 19651208	19751207 19751208	2 ¹³ / ₁₆	7 ¹³ / ₁₆	1 ¹ / ₃₂	4 ¹ / ₂	5 ¹ / ₁₆
2 ¹ / ₁₆ 2 ³ / ₄ 2 ¹⁵ / ₁₆ 3	19651211 19651212 19651215 19651300	19751211 19751212 19751215 19751300	2 ¹³ / ₁₆	9 ¹ / ₈	1 ²⁵ / ₃₂	4 ³ / ₄	5 ⁷ / ₈
3 ⁷ / ₁₆ 3 ¹ / ₂	19651307 19651308	19751307 19751308	3 ²⁵ / ₆₄	10 ¹ / ₄	1 ²⁵ / ₃₂	6	6 ³ / ₈
3 ¹⁵ / ₁₆ 4	19651307 19651308	19751307 19751308	3 ³¹ / ₆₄	12 ⁹ / ₁₆	2 ¹ / ₁₆	7	8 ³ / ₈

Refer to Mounting and Dismounting Instructions on pages 121 and 122.

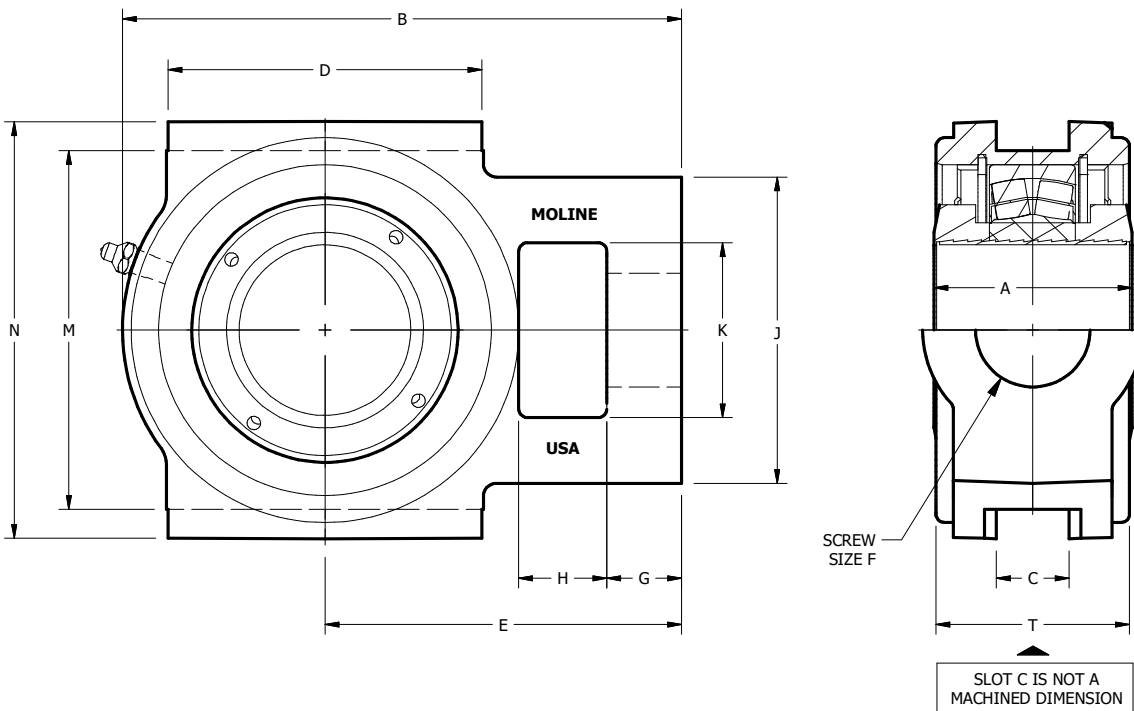

M3000 EVEN-LOK™ WIDE SLOT TAKE-UP

SHAFT SIZE	DIMENSIONS (INCHES)								WEIGHT LBS.
	F	G	H	J	K	M	N	T	
1 ¹⁵ / ₁₆ 2	1	¹⁵ / ₁₆	³ / ₄	3 ⁵ / ₁₆	1 ¹⁵ / ₁₆	4	4 ³ / ₄	2 ⁷ / ₁₆	12
2 ³ / ₁₆	1 ¹ / ₈	1	1	3 ⁷ / ₈	2 ¹ / ₄	4 ¹ / ₂	5 ¹ / ₄	2 ⁹ / ₁₆	16
2 ⁷ / ₁₆ 2 ¹ / ₂	1 ¹ / ₂	1 ¹ / ₁₆	1 ¹ / ₄	4 ¹ / ₄	2 ¹ / ₂	5 ¹ / ₈	6	2 ³ / ₄	21
2 ¹¹ / ₁₆ 2 ³ / ₄ 2 ¹⁵ / ₁₆ 3	1 ¹ / ₂	1 ³ / ₈	1 ¹ / ₄	4 ⁷ / ₈	2 ³ / ₄	5 ¹⁵ / ₁₆	6 ³ / ₄	3	30
3 ⁷ / ₁₆ 3 ¹ / ₂	1 ³ / ₄	1 ¹ / ₁₆	1 ⁵ / ₈	4 ⁷ / ₈	2 ⁷ / ₈	6 ¹³ / ₁₆	7 ¹³ / ₁₆	3 ⁵ / ₈	45
3 ¹⁵ / ₁₆ 4	2	2 ¹ / ₁₆	2 ¹ / ₈	6	3 ³ / ₈	8 ⁵ / ₈	9 ⁷ / ₁₆	3 ¹ / ₂	72

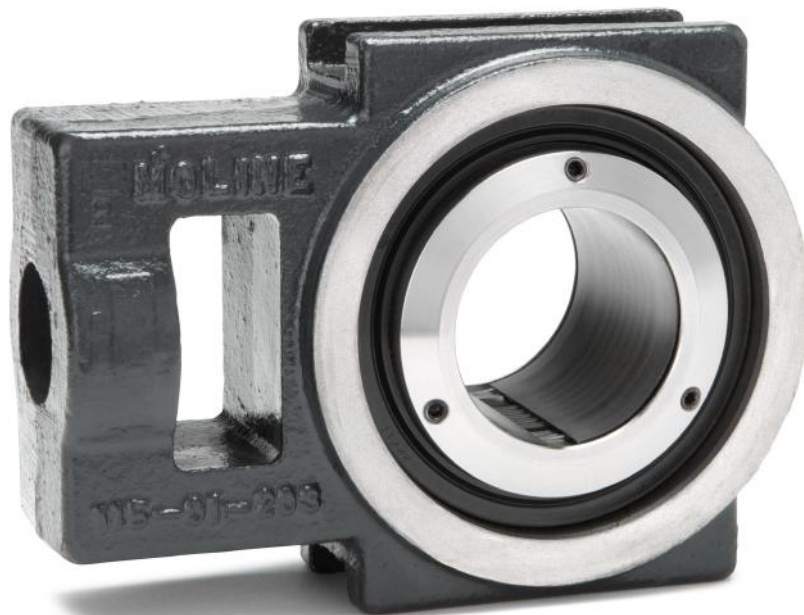

For personal service 800.242.4633
 CAD drawings at no additional charge
 For nomenclature see pages 240 and 241

MOLINE BEARING CO



M3000 EVEN-LOK™ APPLICATION GUIDE

At Moline, our goal is to provide you with the most reliable products, helpful service, and expert support. We work to make our application guides clear and easy to understand. But if you have further questions, please contact us.

800.242.4633

LUBRICATION - VARIOUS OPERATIONS

Normal Operation

Your Moline bearing has been greased at the factory and is ready to install and run. When establishing a re-lubrication schedule, note that a small amount of grease at frequent intervals is preferable to a large amount of grease at infrequent intervals. Table 2 below is a general guide for Lubrication. It should be noted that certain conditions may require a change of lubricating periods as dictated by experience.

High Speed Operation

At higher operating speeds, too much grease may cause overheating. In these cases, the amount of lubrication can only be determined by experience. If excess grease in the bearing causes overheating, it will be necessary to remove grease fitting and run for 10 minutes. This will allow excess grease to escape. Then wipe off excess grease and replace grease fitting.

Operating Temperatures

Normal temperature may range from “cool or warm to the touch” up to a point of “too hot to touch for more than a few seconds,” depending on the bearing size, speed and surrounding conditions. Abnormal bearing temperature may indicate faulty lubrication practices. Unusually high temperature accompanied by excessive leakage of grease indicates too much grease. High temperature with no grease showing at the seals, particularly if the bearing is noisy, usually indicates too little grease. Normal temperature and a slight showing of grease at the seals indicate proper lubrication.

Special Operating Conditions

Refer acid, chemical, extreme or other special operating conditions to the factory.

LUBRICATION INSTRUCTIONS

Moline bearings have been lubricated at the factory with No. 2 consistency lithium base grease that is suitable for normal operating applications. Many ordinary cup greases will disintegrate at speeds far below those at which Moline bearings will operate successfully if proper grease is used. Relubricate with lithium base grease or a grease that is compatible with original lubricant and suitable for roller bearing service. It should be noted that when re-lubricating, adding a small amount of grease on a frequent basis is preferable to a large amount of grease infrequently. In unusual cases consult the factory or a reputable grease supplier.

Storage or Special Shutdown

If equipment will be idle for some time, before shutting down, add grease to the bearing, rotating the sleeve to distribute grease. If possible, cover the bearing to protect from dust and other contaminants. This will ensure protection of the bearing, particularly when exposed to severe environmental conditions. After lengthy storage or idle period, add fresh grease before starting.

TABLE 2 - LUBRICATION CHART

HOURS RUN PER DAY	SUGGESTED LUBRICATION PERIOD IN WEEKS							
	1 TO 250 RPM	251 TO 500 RPM	501 TO 750 RPM	751 TO 1000 RPM	1001 TO 1500 RPM	1501 TO 2000 RPM	2001 TO 2500 RPM	2501 TO 3000 RPM
8	12	12	10	7	5	4	3	2
16	12	7	5	4	2	2	2	1
24	12	5	3	2	1	1	1	1

Read Operations and Lubrication sections above before establishing lubrication schedule.



M3000 EVEN-LOK™ APPLICATION GUIDE

MOUNTING INSTRUCTIONS

It is critical to the performance of the bearing that it be mounted properly. Failure to follow proper mounting practice may result in reduced bearing life.



1. Clean the base of the bearing and support surface on which it rests. Be sure the supporting surface is flat. If the bearing elevation must be adjusted by shims, the shims **MUST** extend the full length and width of the support surface.
2. Slide the bearing, with the mounting side facing outward, on the shaft where the unit is to be secured. Bolt the housing securely to the support. Note: The mounting side of the bearing is the side with the circle of set screws.
3. The Expansion bearing must be centered in the housing to allow for axial shaft expansion. Move the bearing axially in the housing in both directions as far as it will go and determine the centered position. It will be necessary to relieve the bearing load while moving the assembly.
4. Snug the mounting screws located in the mounting side collar to finger tightness holding the short leg of the supplied Even-lok™ wrench. Tighten the mounting screws a total of ½ turn by alternately tightening in two increments (¼ turn and ¼ turn). Please refer to the following diagram for proper tightening pattern for each bearing size:

- Do not remove plastic end cap or plastic protection plugs inserted in the set screw holes (on some older style inserts) until you are ready to install bearing onto shaft.
- Do not disassemble bearing prior to installation.
- **Do not tighten any mounting screws prior to installation.**
- Use only the supplied Even-lok™ wrench for tightening set screws on bearing. After storage or idle period, add a little fresh grease before running.

For optimum bearing performance, it is important to start the mounting process with a shaft that is free of burrs and dirt. Please review your shaft and file down burrs and wipe clean then lubricate shaft with light oil. Check shaft diameter and review recommended shaft tolerances below:

SHAFT DIAMETER	TOLERANCE
1 7/16"–1 15/16"	+.000" to -.003"
2"– 4"	+.000" to -.004"

After choosing the best bearing, make sure you specify the optimal grease for the application.

We use premium Timken™ All Purpose lithium grease to assemble our bearings.

Moline Bearing has access to many of the differing Lubricants on the market today. If you have special or specific performance requirements from the lubricant used for your application, please contact us with the details and we will be glad to accommodate your request.



M3000 EVEN-LOK™ APPLICATION GUIDE CONTINUED

M3000 TIGHTENING PATTERNS

5. Tighten each set screw until the long end of the Even-lok™ wrench bows ½" under finger pressure or torque to 5.5 lb.ft. **Caution:** Do not use power driven or auxiliary equipment such as a hammer or pipe in tightening the screws.

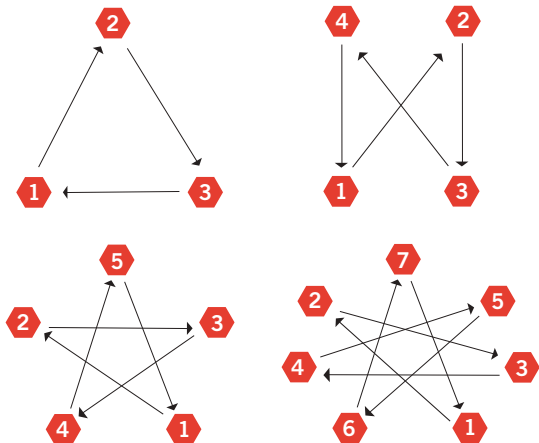

6. Check for misalignment.
 7. Secure the mounting bolts to the support structure tightly.
 8. **Within the first 24 hours of operation, recheck the mounting side screws to the correct torque specifications in step 5 above.**



DISMOUNTING INSTRUCTIONS

1. Clean the bearing and shaft extension of any burrs or rust.
2. It is recommended to lift and support the bearing assembly and shaft extension before dismounting.
3. Loosen the set screws in the mounting collar by a few turns. The pre-loaded wave springs inside the locking mechanism will assist to release the bearing sleeve. The bearing should release from the shaft. If not, tap gently with a rubber hammer on the back-up ring located on the opposite side of the bearing, to release the sleeve.
4. Remove the bearing mounting bolts.
5. Slide the bearing unit off the shaft.

SELECTING THE CORRECT SPHERICAL

Moline spherical bearings have the capacity to carry substantial radial loads, thrust loads or a combined radial and thrust load. The maximum load that can be applied is limited by the various components in the system, and the life requirements listed in this catalog. The factory should be consulted on any application that exceeds the recommendations in the catalog. See page 123.

Select a bearing from the M3000 load-rating chart on page 124 having a radial load rating at the operating speed equal to or greater than the calculated Equivalent Radial Load for a desired L10 life. This simple method is all that is necessary for most general applications and provides for occasional shock loads.

L10 Hours of Life – Is the life that may be expected from at least 90% of a given group of bearings operated under identical conditions. The average life (L50) will be approximately five times the L10 life. See page 124.

For further L10 calculations needed to select and verify the correct Spherical for your application, please refer to the text description on page 80 in conjunction with the M3000 Charts on the following page 123 and 124.



M3000 EVEN-LOK™ APPLICATION GUIDE

M3000 Even-Lok™ Thrust Factors and Seal Speed

SHAFT SIZE	e	LIGHT THRUST IF FA/FR ≤ E		HEAVY THRUST IF FA/FR ≥ E		LOAD RATING		SEAL SPEED LIMITS	
		X	Y	X	Y	DYNAMIC C LBS.	STATIC C ₀ LBS.	CONTACT DOUBLE LIP RPM	LABYRINTH RPM
1 7/16 – 1 1/2	.28	1.0	2.4	.67	3.6	22900	22000	3800	5900
1 11/16 – 1 3/4	.26	1.0	2.6	.67	3.9	20200	19800	3500	5400
1 15/16 – 2	.24	1.0	2.8	.67	4.2	21700	22500	3300	4900
2 3/16	.24	1.0	2.8	.67	4.2	30100	30800	3100	4500
2 7/16 – 2 1/2	.24	1.0	2.8	.67	4.2	43400	41100	2700	3800
2 11/16 – 3	.22	1.0	3.0	.67	4.6	47700	54000	2500	3300
3 7/16 – 3 1/2	.23	1.0	2.8	.67	4.2	65200	76400	2100	2800
3 15/16 – 4	.24	1.0	2.8	.67	4.2	81000	93300	2000	2500

* Comparing Spherical to Tapered Roller Bearings—The dynamic capacity C (Spherical) and C90 (Tapered) are not the same base. To compare basic dynamic capacities, multiply C x .259 and compare to C90.



M3000 EVEN-LOK™ RADIAL LOAD RATINGS

NOMINAL SHAFT DIAMETER (IN)	L10 HRS LIFE	RADIAL LOAD RATINGS AT VARIOUS REVOLUTIONS PER MINUTE								
		50	200	500	1200	1800	2200	2800	3500	4000
1 7/16 1 1/2	5000	9630	6354	4827	3712	3287	3095	2879	2692	2586
	10000	7822	5161	3920	3015	2670	2514	2338	2187	2101
	20000	6354	4192	3184	2449	2168	2042	1899	1776	1706
	50000	4827	3184	2419	1860	1647	1551	1443	1349	1296
	100000	3920	2586	1965	1511	1338	1260	1172	1096	1053
1 11/16 1 3/4	5000	10207	6734	5116	3934	3483	3280	3051	2853	-----
	10000	8291	5470	4155	3195	2829	2664	2478	2318	-----
	20000	6734	4443	3375	2596	2298	2164	2013	1883	-----
	50000	5116	3375	2564	1972	1746	1644	1529	1430	-----
	100000	4155	2741	2083	1602	1418	1335	1242	1162	-----
1 15/16 2	5000	10385	6851	5205	4002	3544	3337	3104	2903	-----
	10000	8435	5565	4227	3251	2879	2710	2521	2358	-----
	20000	6851	4520	3434	2641	2338	2202	2048	1915	-----
	50000	5205	3434	2609	2006	1776	1672	1556	1455	-----
	100000	4227	2789	2119	1629	1443	1358	1264	1182	-----
2 3/16	5000	12470	8227	6250	4806	4256	4007	3728	-----	-----
	10000	10129	6683	5077	3904	3457	3255	3028	-----	-----
	20000	8227	5428	4123	3171	2808	2644	2459	-----	-----
	50000	6250	4123	3132	2409	2133	2008	1868	-----	-----
	100000	5077	3349	2544	1957	1733	1631	1517	-----	-----
2 7/16 2 1/2	5000	19260	12707	9653	7423	6573	6189	5757	-----	-----
	10000	15644	10321	7841	6030	5339	5027	4676	-----	-----
	20000	12707	8384	6369	4898	4337	4083	3798	-----	-----
	50000	9653	6369	4838	3721	3294	3102	2885	-----	-----
	100000	7841	5173	3930	3022	2676	2520	2344	-----	-----
2 11/16 2 3/4 2 15/16 3	5000	21169	13966	10609	8159	7224	6802	-----	-----	-----
	10000	17194	11344	8618	6627	5868	5525	-----	-----	-----
	20000	13966	9214	7000	5383	4766	4488	-----	-----	-----
	50000	10609	7000	5317	4089	3621	3409	-----	-----	-----
	100000	8618	5685	4319	3321	2941	2769	-----	-----	-----
3 7/16 3 1/2	5000	32441	21403	16259	12503	11071	10425	-----	-----	-----
	10000	26350	17385	13206	10156	8993	8467	-----	-----	-----
	20000	21403	14121	10727	8249	7304	6878	-----	-----	-----
	50000	16259	10727	8149	6267	5549	5225	-----	-----	-----
	100000	13206	8713	6619	5090	4507	4244	-----	-----	-----
3 15/16 4	5000	42470	28020	21286	16369	14494	13647	-----	-----	-----
	10000	34497	22759	17289	13296	11773	11085	-----	-----	-----
	20000	28020	18486	14043	10800	9563	9004	-----	-----	-----
	50000	21286	14043	10668	8204	7264	6840	-----	-----	-----
	100000	17289	11407	8665	6664	5900	5556	-----	-----	-----

Refer to page 123 for seal speed limits. For applications that exceed the load ratings above, contact the factory for assistance.



M3000 EVEN-LOK™ SERIES INTERCHANGE

PAGE	MOLINE	SKF CONCENTRA™	SEALMASTER	REX SHURLOK™ ADAPTOR MOUNTED	DODGE IMPERIAL
110	2-Bolt Pillow Block 19621 (Expansion) 19721 (Non-Expansion)	SYR-N SYR-NH	USRB5000A USRB5000	ZAS6000 ZA6000	P2BIP <i>or</i> 0694 -----
112	4-Bolt Pillow Block 19641 (Expansion) 19741 (Non-Expansion)	FSYR-N FSYR-NH	USRBF5000A USRBF5000	ZAS6000-F ZA6000-F	P4BIP <i>or</i> 0695 -----
114	4-Bolt Flange 19611 (Expansion) 19711 (Non-Expansion)	FYR-N* FYR-NH*	USFB5000A USFB5000	ZF6000* ZFS6000*	F4SIP <i>or</i> 0697 -----
116	Piloted Flange 19631 (Expansion) 19731 (Non-Expansion)	FYRP-N FYRP-NH	USFC5000A USFC5000A	----- ZBR6000	FCIP <i>or</i> 0698 -----
118	Wide Slot Take-Up 19651 (Expansion) 19751 (Non-Expansion)	TBR-N TBR-NH	USTU5000A USTU5000	----- ZT6000	WSTUIP <i>or</i> 0693 -----

* Manufacture square and round 4-bolt flange.
Can dimensionally interchange with standard Moline M2000.

This is a general dimensional interchange, for exact comparison information, please contact the factory.
For Nomenclature see pages 240-241.





ME3000™

SPHERICAL
ROLLER
BEARINGS
WITH
TYPE E
DIMENSIONS

Solid cast iron housing,
with center support
Made in the USA

Even-Lok™ bearing provides
near 360°/100%
interface with shaft

Large diameter rollers for
optimum capacity

Elongated bolt holes
permit adjustment and
increased mounting
options

Readily accessible
mounting screws for
easy installation

Sealed, pre-lubricated
bearing eliminates
most environmental
contamination

Type E Footprint
Spherical Insert

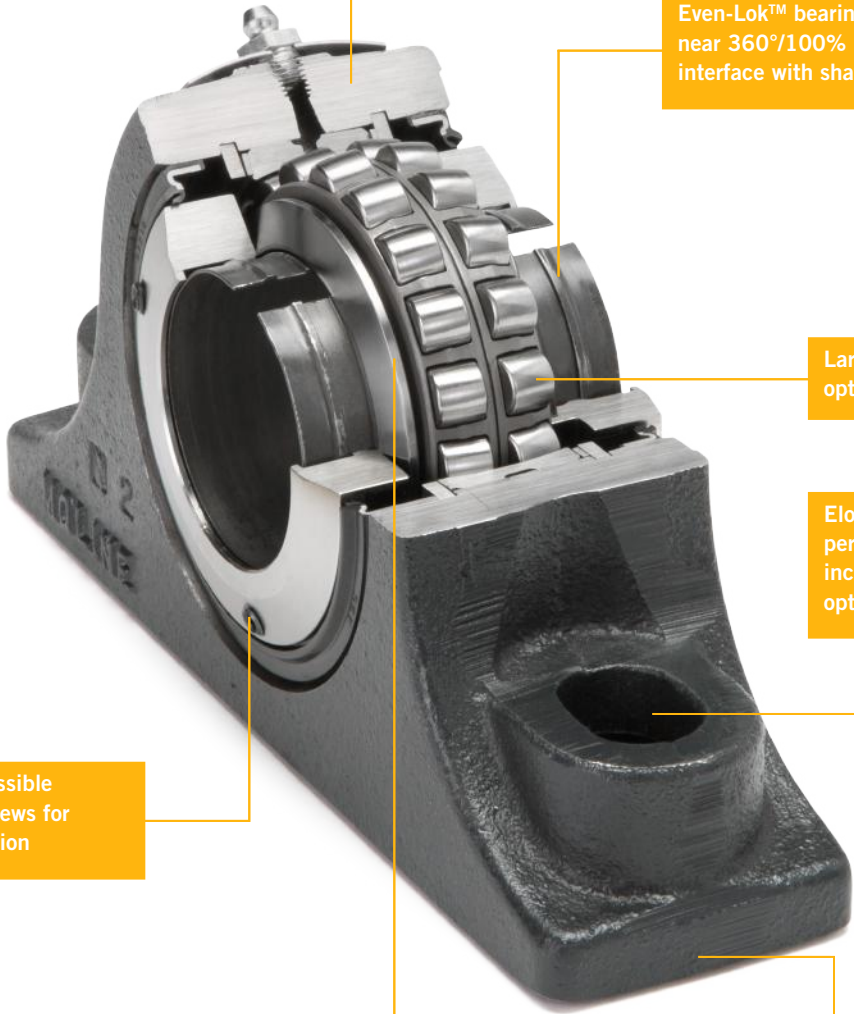

MOLINE ME-3000 EVEN-LOK™ SPHERICAL E ROLLER BEARINGS
WITH TYPE E DIMENSIONS

SKF SKF INSERT INSIDE



FEATURES OF MOLINE ME3000 EVEN-LOK™ SPHERICAL ROLLER BEARINGS WITH TYPE E DIMENSIONS

WITH SKF® ROLLER BEARINGS

- For applications that require expansion and misalignment capability and a Type E dimensional “footprint”
- Dimensionally interchangeable with comparable competitive Spherical Roller Bearing units, Moline Split E1000, Moline ME2000
- Suggested Industry Applications: Conveying, Screening, Air Handling, Industrial Laundries, High Speed Fans
- Available in shaft sizes from 1 7/16" to 4"
- Assembled, adjusted and pre-lubricated in advance for immediate use
- Built with SKF™ Explorer Spherical Roller Bearings
- Supplies near 360° locking around, and near 100% interface with the shaft that eliminates slippage due to vibration
- Supplied with special Hex-L Key Allen wrench for easy mounting and dismounting
- +/- 1 1/2° misalignment capacity
- Available in Expansion (red tag) and Non-Expansion (yellow tag) styles
- Expansion units have .100" capacity
- Compared to traditional set screw locking, concentric locking reduces fretting corrosion
- Distributes locking force equally through Even-Lok™, reducing the risk of particle infiltration in the inner sleeve
- Available with Standard Double Lip Contact Seal made by SKF® or Balanced Steel Labyrinth Seals
- Timken™ Lithium Complex Grease operating temperature is up to 250°, High temperature grease is available up to 350°
- For custom lubrication, please see page 154 or contact the factory for more information
- Housings of Class 30 cast iron are made in Illinois, Iowa and Wisconsin
- Housings available in the standard painted finish. Powder coating in RAL or custom colors, Stainless Steel Powder coating, Nickel-plating, Epoxy, Teflon and other coatings are available. See page 150 or contact the factory for further information
- Custom machining and design service are available. See page 146 or contact the factory for further information
- Made in the United States

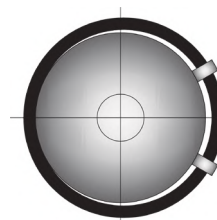

Traditional Set
Screw Locking

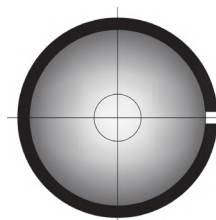

M3000 Even-Lok™

Standard Double Lip Contact Seal made by SKF®



Balanced Steel Labyrinth Seal for high speed and high temp applications



ME3000 EVEN-LOK™ 2-BOLT PILLOW BLOCK WITH TYPE E DIMENSIONS

SHAFT SIZE	MOLINE PART #		DIMENSIONS (INCHES)											WT. LBS.
	EXP	NON-EXP	A	B	C	MIN D	CENTER TO CENTER D	MAX D	F	G	H	J	M	
1 7/16	29621107	29721107	2 9/16	7 3/8	2 1/8	5	5 1/2	6	1/2	1 1/8	1 1/8	3 7/8	1 7/8	6.9
1 1/2	29621108	29721108	2 9/16	7 7/8	2 3/8	5 5/8	6 1/16	6 1/2	1/2	1 1/16	1 1/4	4 1/4	2 1/8	9.0
1 15/16	29621111	29721111												
1 3/4	29621112	29721112	2 9/16	8 7/8	2 7/16	6 1/8	6 11/16	7 1/4	5/8	1 5/16	1 3/8	4 1/2	2 1/4	10.5
1 15/16	29621115	29721115												
2	29621200	29721200												
2 3/16	29621203	29721203	2 19/32	9 5/8	2 5/8	6 11/16	7 3/8	8	5/8	1 7/16	1 1/2	5	2 1/2	11.8
2 7/16	29621207	29721207	2 13/16	10 1/2	2 7/8	7 1/8	7 7/8	8 5/8	5/8	1 1/2	1 5/8	5 11/16	2 3/4	17.5
2 1/2	29621208	29721208												
2 11/16	29621211	29721211	2 13/16	12	3	7 7/8	8 13/16	9 3/4	3/4	1 13/16	1 7/8	6 5/16	3 1/8	24.0
2 3/4	29621212	29721212												
2 15/16	29621215	29721215												
3	29621300	29721300												
3 7/16	29621307	29721307	3 25/64	14	3 5/8	9 3/4	10 5/8	11 1/2	7/8	1 7/8	2 1/4	7 1/2	3 3/4	34.5
3 1/2	29621308	29721308												

Refer to Mounting and Dismounting Instructions on pages 137 and 138.



ME3000 EVEN-LOK™ 2-BOLT PILLOW BLOCK WITH TYPE E DIMENSIONS

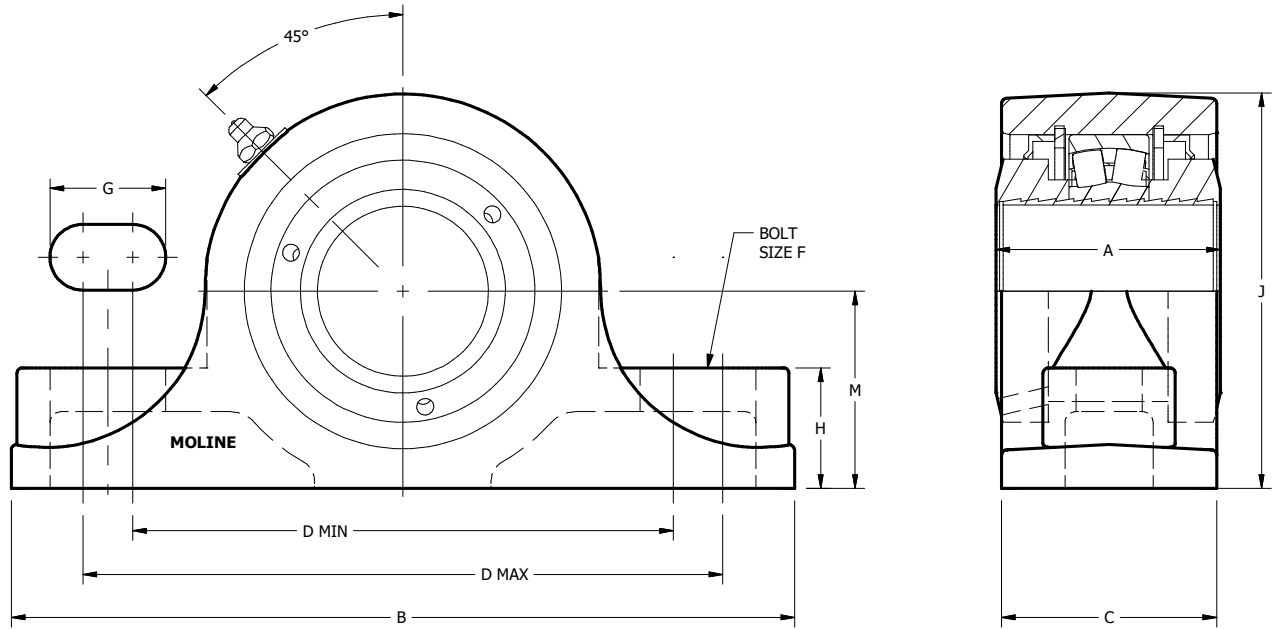

ME3000 EVEN-LOK™ 4-BOLT FLANGE WITH TYPE E DIMENSIONS

SHAFT SIZE	MOLINE PART #		DIMENSIONS (INCHES)								WEIGHT LBS.
	EXP	NON-EXP	A	B	C	D	F	H	J	L*	
1 7/16	29611107	29711107	2 9/16	4 5/8	2 19/32	3 1/2	1/2	1 1/16	3 7/8	2 5/8	7.2
1 1/2	29611108	29711108	2 9/16	5 3/8	2 31/32	4 1/8	1/2	1 3/16	4 1/4	2 13/16	11.93
1 11/16	29611111	29711111									11.31
1 3/4	29611112	29711112	2 9/16	5 5/8	3 3/32	4 3/8	1/2	1 3/16	4 1/2	3	12.6
1 15/16	29611115	29711115									11.9
2	29611200	29711200									
2 3/16	29611203	29711203	2 19/32	6 1/4	3 9/32	4 7/8	5/8	1 3/8	4 7/8	3 3/16	14.6
2 7/16	29611207	29711207	2 13/16	6 7/8	3 9/16	5 3/8	5/8	1 1/2	5 3/4	3 5/8	23.5
2 1/2	29611208	29711208									
2 11/16	29611211	29711211	2 13/16	7 3/4	3 15/16	6	3/4	1 5/8	6 1/2	4	31.5
2 3/4	29611212	29711212									
2 15/16	29611215	29711215									
3	29611300	29711300									
3 7/16	29611307	29711307	3 25/64	9 1/4	4 1/2	7	3/4	1 7/8	7 5/8	4 3/4	51.5
3 1/2	29611308	29711308									
3 15/16	29611315	29711315	3 31/64	10 1/4	5 5/8	7 3/4	7/8	2 1/8	8 7/16	5 1/8	64.8
4	29611400	29711400									

Refer to Mounting and Dismounting Instructions on pages 137 and 138.

* In some cases the bearing insert protrudes past the base of the housing. Clearance for drive collar "L" is required.



ME3000 EVEN-LOK™ 4-BOLT FLANGE WITH TYPE E DIMENSIONS

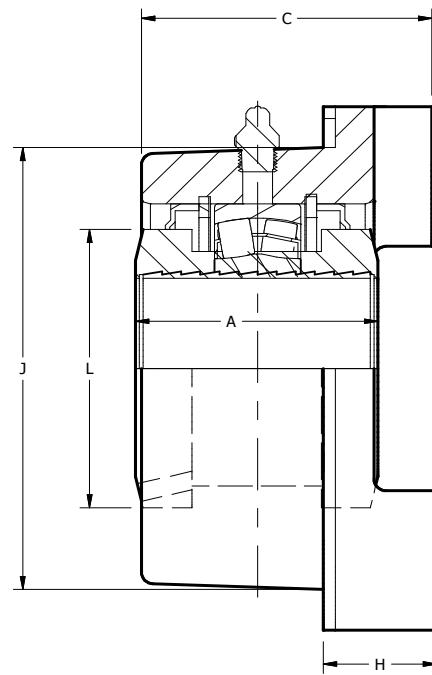
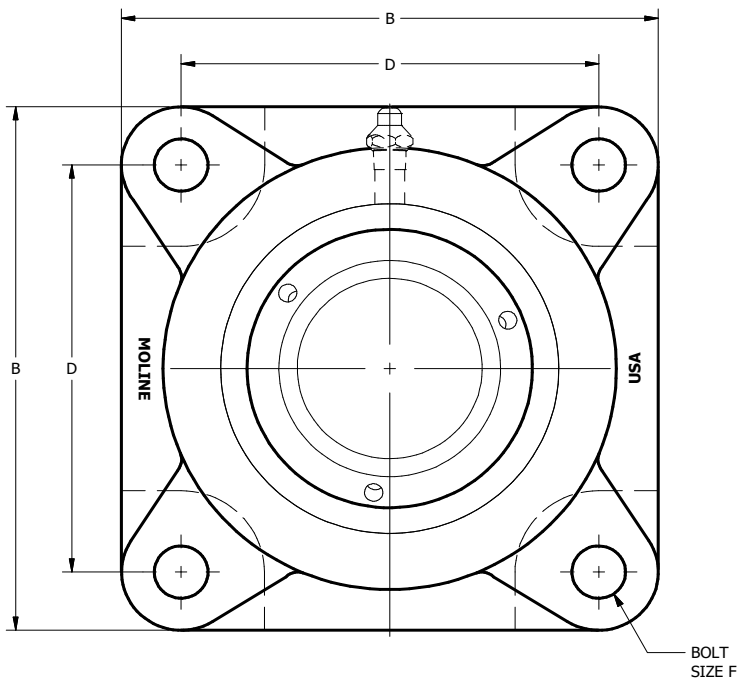

ME3000 EVEN-LOK™ PILOTED FLANGE CARTRIDGE WITH TYPE E DIMENSIONS

SHAFT SIZE	MOLINE PART #		DIMENSIONS (INCHES)										WEIGHT LBS.
	EXP	NON-EXP	A	B	C	D	E	F	G	H	K	M	
1 1/16	29631111	29731111	2 9/16	6 1/8	2 3/16	5 1/8	7/8	7/16	3/4	1/2	4 1/4	3 5/8	8.5
1 15/16 2	29631115 29631200	29731115 29731200	2 9/16	6 3/8	2 3/16	5 3/8	7/8	7/16	1 1/16	1/2	4 1/2	3 51/64	10.5
2 3/16	29631203	29731203	2 19/32	7 1/8	2 7/16	6	1	1/2	15/16	1/2	5	4 1/4	14.5
2 7/16 2 1/2	29631207 29631208	29731207 29731208	2 13/16	7 5/8	2 11/16	6 1/2	1	1/2	1 1/16	5/8	5 1/2	4 19/32	16
2 11/16 2 3/4 2 15/16 3	29631211 29631212 29631215 29631300	29731211 29731212 29731215 29731300	2 13/16	8 3/4	2 13/16	7 1/2	1 1/4	5/8	1	3/4	6 3/8	5 19/64	22
3 7/16 3 1/2	29631307 29631308	29731307 29731308	3 25/64	10 1/4	3 1/4	8 5/8	1 1/4	3/4	1 1/2	15/16	7 3/8	6 3/32	33
3 15/16 4	29631315 29631400	29731315 29731400	3 31/64	10 7/8	3 9/16	9 3/8	1 1/2	3/4	1 7/16	1 1/16	8 1/8	6 5/8	45

Refer to Mounting and Dismounting Instructions on pages 137 and 138.

For applications that exceed the load ratings above, please contact the factory for assistance.



ME3000 EVEN-LOK™ PILOTED FLANGE CARTRIDGE WITH TYPE E DIMENSIONS

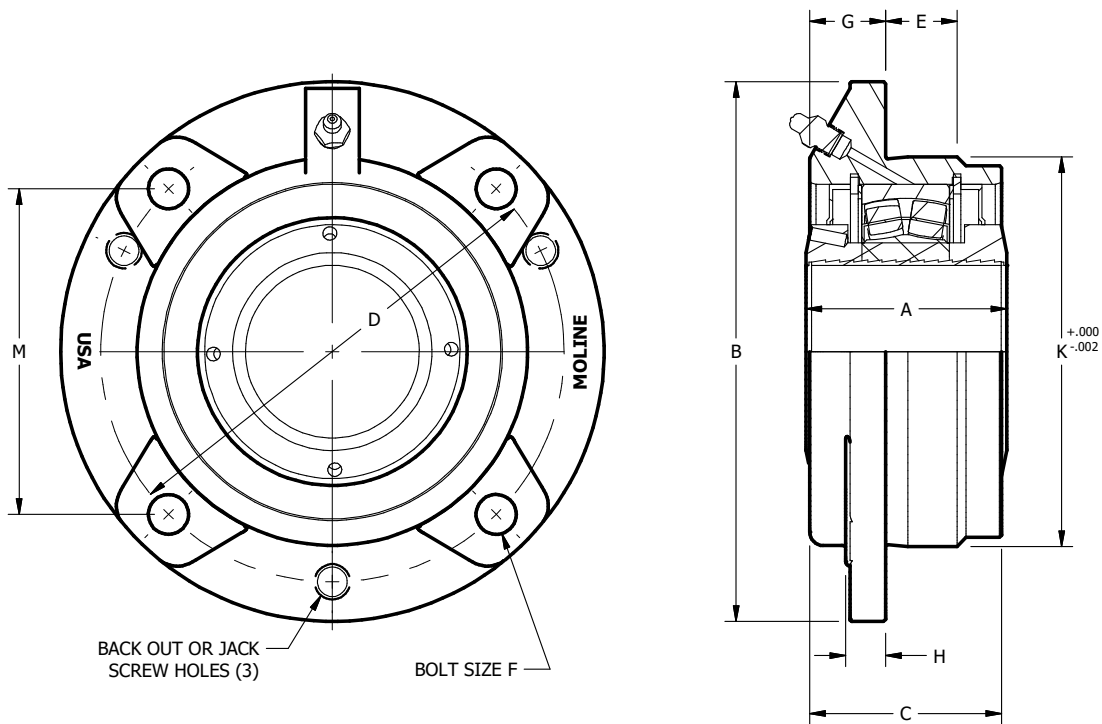

ME3000 EVEN-LOK™ APPLICATION GUIDE

At Moline, our goal is to provide you with the most reliable products, helpful service, and expert support. We work to make our application guides clear and easy to understand. But if you have further questions, please contact us. 800.242.4633



LUBRICATION - VARIOUS OPERATIONS

Normal Operation

Your Moline bearing has been greased at the factory and is ready to install and run. When establishing a re-lubrication schedule, note that a small amount of grease at frequent intervals is preferable to a large amount of grease at infrequent intervals. Table 1 below is a general guide for Lubrication. It should be noted that certain conditions may require a change of lubricating periods as dictated by experience.

High Speed Operation

At higher operating speed, too much grease may cause overheating. In these cases, the amount of lubrication can

only be determined by experience. If excess grease in the bearing causes overheating, it will be necessary to remove grease fittings and run for 10 minutes. This will allow excess grease to escape. Then wipe off excess grease and replace grease fittings.

Operating Temperatures

Normal temperature may range from “cool or warm to the touch” up to a point of “too hot to touch for more than a few seconds,” depending on the bearing size, speed and surrounding conditions. Abnormal bearing temperature may indicate faulty lubrication practices. Unusually high temperature accompanied by excessive leakage of grease indicates too much grease. High temperature with no grease showing at the seals, particularly if the bearing is noisy, usually indicates too little grease. Normal temperature and a slight showing of grease at the seals indicate proper lubrication.

Special Operating Conditions

Refer acid, chemical, extreme or other special operating conditions to the factory.

LUBRICATION INSTRUCTIONS

Moline bearings have been lubricated at the factory with No. 2 consistency lithium base grease that is suitable for normal operating applications. Many ordinary cup greases will disintegrate at speeds far below those at which Moline bearings will operate successfully if proper grease is used. Relubricate with lithium base grease or a grease that is compatible with original lubricant and suitable for roller bearing service. It should be noted that when re-lubricating, adding a small amount of grease on a frequent basis is preferable to a large amount of grease infrequently. In unusual cases consult the factory or a reputable grease supplier.

HOURS RUN PER DAY	SUGGESTED LUBRICATION PERIOD IN WEEKS							
	1 TO 250 RPM	251 TO 500 RPM	501 TO 750 RPM	751 TO 1000 RPM	1001 TO 1500 RPM	1501 TO 2000 RPM	2001 TO 2500 RPM	2501 TO 3000 RPM
8	12	12	10	7	5	4	3	2
16	12	7	5	4	2	2	2	1
24	12	5	3	2	1	1	1	1

Read Operations and Lubrication sections above before establishing lubrication schedule.



ME3000 EVEN-LOK™ APPLICATION GUIDE

Storage or Special Shutdown

If equipment will be idle for some time, before shutting down, add grease to the bearing, rotating the sleeve to distribute grease. If possible, cover the bearing to protect from dust and other contaminants. This will ensure protection of the bearing, particularly when exposed to severe environmental conditions. After lengthy storage, add a small amount of fresh grease before running.

MOUNTING INSTRUCTIONS

It is critical to the performance of the bearing that it be mounted properly. Failure to follow proper mounting practice may result in reduced bearing life.

- Do not remove plastic end cap or plastic protection plugs inserted in the set screw holes (on some older style inserts) until you are ready to install bearing onto shaft.
- Do not disassemble bearing prior to installation.
- **Do not tighten any mounting screws prior to installation.**
- Use only the supplied Even-lok™ wrench for tightening set screws on bearing. After storage or idle period, add a little fresh grease before running.

For optimum bearing performance, it is important to start the mounting process with a shaft that is free of burrs and dirt. Please review your shaft and file down burrs and wipe clean then lubricate shaft with light oil. Check shaft diameter and review recommended shaft tolerances below:

SHAFT DIAMETER	TOLERANCE
1 7/16"–1 15/16"	+ .000" to -.003"
2"– 4"	+ .000" to -.004"

1. Clean the base of the bearing and support surface on which it rests. Be sure the supporting surface is flat. If the bearing elevation must be adjusted by shims, the shims **MUST** extend the full length and width of the support surface.
2. Slide the bearing, with the mounting side facing outward, on the shaft where the unit is to be secured. Bolt the housing securely to the support. Note: The mounting side of the bearing is the side with the circle of set screws.
3. The Expansion bearing must be centered in the housing to allow for axial shaft expansion. Move the bearing axially in the housing in both directions as far as it will go and determine the centered position. It will be necessary to relieve the bearing load while moving the assembly.
4. Snug the mounting screws located in the mounting side collar to finger tightness holding the short leg of the supplied Even-lok™ wrench. Tighten the mounting screws a total of ½ turn by alternately tightening in two increments (¼ turn and ¼ turn). Please refer to the following diagram for proper tightening pattern for each bearing size:



ME3000 EVEN-LOK™ APPLICATION GUIDE CONTINUED

ME3000 TIGHTENING PATTERNS

5. Tighten each set screw until the long end of the Even-lok™ wrench bows ½" under finger pressure or torque to 5.5 lb.ft.. Caution: Do not use power driven or auxiliary equipment such as a hammer or pipe in tightening the screws.

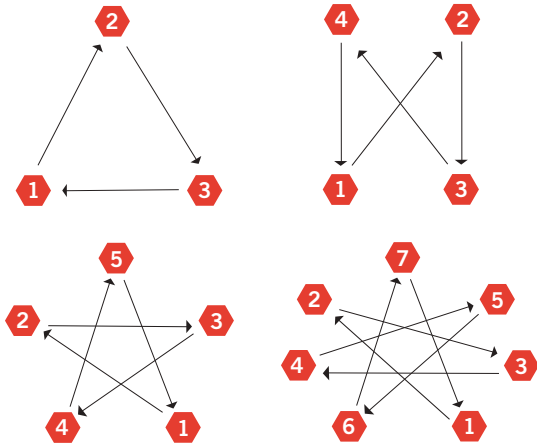

6. Check for misalignment.
7. Secure the mounting bolts to the support structure tightly.
8. **Within the first 24 hours of operation, recheck the mounting side screws to the correct torque specifications in step 5 above.**

DISMOUNTING INSTRUCTIONS

1. Clean the bearing and shaft extension of any burrs or rust.
2. It is recommended to lift and support the bearing assembly and shaft extension before dismounting.
3. Loosen the set screws in the mounting collar by a few turns. The pre-loaded wave springs inside the locking mechanism will assist to release the bearing sleeve. The bearing should release from the shaft. If not, tap gently with a rubber hammer on the back-up ring located on the opposite side of the bearing, to release the sleeve.
4. Remove the bearing mounting bolts.
5. Slide the bearing unit off the shaft.

SELECTING THE CORRECT SPHERICAL

Moline spherical bearings have the capacity to carry substantial radial loads, thrust loads or a combined radial and thrust load. The maximum load that can be applied is limited by the various components in the system, and the life requirements listed in this catalog. The factory should be consulted on any application that exceeds the recommendations in the catalog. See page 139.

Select a bearing from the ME3000 load-rating chart on page 140 having a radial load rating at the operating speed equal to or greater than the calculated Equivalent Radial Load for a desired L10 life. This simple method is all that is necessary for most general applications and provides for occasional shock loads.

L10 Hours of Life – Is the life that may be expected from at least 90% of a given group of bearings operated under identical conditions. The average life (L50) will be approximately five times the L10 life. See page 140.

For further L10 calculations needed to select and verify the correct Spherical for your application, please refer to the text description on page 98 in conjunction with the ME3000 Charts on the following page 139 and 140.

ME3000 EVEN-LOK™ APPLICATION GUIDE CONTINUED

ME3000 Even-Lok™ Thrust Factors and Seal Speed

SHAFT SIZE	e	LIGHT THRUST IF FA/FR≤E		HEAVY THRUST IF FA/FR≥E		LOAD RATING		SEAL SPEED LIMITS	
		X	Y	X	Y	DYNAMIC C LBS.	STATIC C ₀ LBS.	CONTACT DOUBLE LIP RPM	LABYRINTH RPM
1 7/16 – 1 1/2	.28	1.0	2.4	.67	3.6	22900	22000	3800	5900
1 11/16 – 1 3/4	.26	1.0	2.6	.67	3.9	20200	19800	3500	5400
1 15/16 – 2	.24	1.0	2.8	.67	4.2	21700	22500	3300	4900
2 3/16	.24	1.0	2.8	.67	4.2	30100	30800	3100	4500
2 7/16 – 2 1/2	.24	1.0	2.8	.67	4.2	43400	41100	2700	3800
2 11/16 – 3	.22	1.0	3.0	.67	4.6	47700	54000	2500	3300
3 7/16 – 3 1/2	.23	1.0	2.8	.67	4.2	65200	76400	2100	2800
3 15/16 – 4	.24	1.0	2.8	.67	4.2	81000	93300	2000	2500

* Comparing Spherical to Tapered Roller Bearings—The dynamic capacity C (Spherical) and C90 (Tapered) are not the same base. To compare basic dynamic capacities, multiply C x .259 and compare to C90.



ME3000 EVEN-LOK™ RADIAL LOAD RATINGS

NOMINAL SHAFT DIAMETER (IN)	L10 HRS LIFE	RADIAL LOAD RATINGS AT VARIOUS REVOLUTIONS PER MINUTE								
		50	200	500	1200	1800	2200	2800	3500	4000
1 7/16 1 1/2	5000	9630	6354	4827	3712	3287	3095	2879	2692	2586
	10000	7822	5161	3920	3015	2670	2514	2338	2187	2101
	20000	6354	4192	3184	2449	2168	2042	1899	1776	1706
	50000	4827	3184	2419	1860	1647	1551	1443	1349	1296
	100000	3920	2586	1965	1511	1338	1260	1172	1096	1053
1 11/16 1 3/4	5000	10207	6734	5116	3934	3483	3280	3051	2853	-----
	10000	8291	5470	4155	3195	2829	2664	2478	2318	-----
	20000	6734	4443	3375	2596	2298	2164	2013	1883	-----
	50000	5116	3375	2564	1972	1746	1644	1529	1430	-----
	100000	4155	2741	2083	1602	1418	1335	1242	1162	-----
1 15/16 2	5000	10385	6851	5205	4002	3544	3337	3104	2903	-----
	10000	8435	5565	4227	3251	2879	2710	2521	2358	-----
	20000	6851	4520	3434	2641	2338	2202	2048	1915	-----
	50000	5205	3434	2609	2006	1776	1672	1556	1455	-----
	100000	4227	2789	2119	1629	1443	1358	1264	1182	-----
2 3/16	5000	12470	8227	6250	4806	4256	4007	3728	-----	-----
	10000	10129	6683	5077	3904	3457	3255	3028	-----	-----
	20000	8227	5428	4123	3171	2808	2644	2459	-----	-----
	50000	6250	4123	3132	2409	2133	2008	1868	-----	-----
	100000	5077	3349	2544	1957	1733	1631	1517	-----	-----
2 7/16 2 1/2	5000	19260	12707	9653	7423	6573	6189	5757	-----	-----
	10000	15644	10321	7841	6030	5339	5027	4676	-----	-----
	20000	12707	8384	6369	4898	4337	4083	3798	-----	-----
	50000	9653	6369	4838	3721	3294	3102	2885	-----	-----
	100000	7841	5173	3930	3022	2676	2520	2344	-----	-----
2 11/16 2 3/4 2 15/16 3	5000	21169	13966	10609	8159	7224	6802	-----	-----	-----
	10000	17194	11344	8618	6627	5868	5525	-----	-----	-----
	20000	13966	9214	7000	5383	4766	4488	-----	-----	-----
	50000	10609	7000	5317	4089	3621	3409	-----	-----	-----
	100000	8618	5685	4319	3321	2941	2769	-----	-----	-----
3 7/16 3 1/2	5000	32441	21403	16259	12503	11071	10425	-----	-----	-----
	10000	26350	17385	13206	10156	8993	8467	-----	-----	-----
	20000	21403	14121	10727	8249	7304	6878	-----	-----	-----
	50000	16259	10727	8149	6267	5549	5225	-----	-----	-----
	100000	13206	8713	6619	5090	4507	4244	-----	-----	-----
3 15/16 4	5000	42470	28020	21286	16369	14494	13647	-----	-----	-----
	10000	34497	22759	17289	13296	11773	11085	-----	-----	-----
	20000	28020	18486	14043	10800	9563	9004	-----	-----	-----
	50000	21286	14043	10668	8204	7264	6840	-----	-----	-----
	100000	17289	11407	8665	6664	5900	5556	-----	-----	-----

Refer to page 139 for seal speed limits. For applications that exceed the load ratings above, contact the factory for assistance.



ME3000 EVEN-LOK™ SERIES INTERCHANGE

PAGE	MOLINE	SKF	SEALMASTER	REX	DODGE
130	2-Bolt Pillow Block 29621 (Expansion) 29721 (Non-Expansion)	SYE-N SYE-NH	USRBE5000A USRBE5000	ZEPS6000 ZEP6000	EP2B-IP-RE EP2B-IP-R
132	4-Bolt Flange 29611 (Expansion) 29711 (Non-Expansion)	----- -----	USFBE5000A USFBE5000	----- ZEF6000	EF4B-IP-RE EF4B-IP-R
134	Piloted Flange 29631 (Expansion) 29731 (Non-Expansion)	----- -----	USFCE5000A USFCE5000	----- -----	EFCIP - 0751 <i>or</i> FCIP - 0698

All units in is interchange have tapered adaptor style locking mechanism.
Can dimensionally interchange with standard Moline Type E, E1000 and ME2000.

This is a general dimensional interchange, for exact comparison information, please contact the factory.
For Nomenclature see pages 240-241.



PAT. 125901

ABCDEFGHIJKLMN O P Q R S T U V W X Y Z

2
411

SPECIALTY
SERVICES

Through a combination of Moline Specialty Services, we provide solutions for a myriad of bearing fit, bearing application and bearing failure challenges.

Whether it's a unique application, spacing requirement, obsolete unit, or up-to-date project, Moline Specialty Services addresses many of the needs and concerns that you face during design, installation and operation.

We work with our customers, field operators and design engineers to source and procure components and processes while taking the most efficient and economical path towards meeting your specific goals and requirements.

Moline is always willing to consider projects and challenges, no matter how small or large...something our competitors won't do.

Engineering, Machining, Fabrication and Assembly Is your customer experiencing bearing failure or broken housings? Is your current bearing no longer in production? Can't find the housing shape or size you need? Let us review your application to offer solutions. We specialize in reverse engineering and improving upon the original design to provide resolution to your bearing challenges.

Coatings and Finishes When you need extra protection for your bearing, or have a unique operating environment, consider using one of our new specialty coatings for your mounted units. Lower your operating costs and extend your bearing service life by protecting your investment with one of our coatings.

Bearing End Caps and Covers Increase the life of your bearings by keeping them clean and free of debris with bearing end caps and bearing covers. Moline offers open and closed end caps, standard bearing covers, and extended shaft bearing covers for all stocked mounted units.

Lubricants After choosing the best Bearing, make sure you specify the optimal grease for the application. Moline has access to many of the differing Lubricants on the market today. If you have special or specific performance requirements from the lubricant used for your application, please contact us with the details and we will be glad to accommodate your request.

Private Label You have worked hard to build your brand and Moline understands this. Take one step further by labeling your mounted units with your company's logo so that the end-user comes back to you for all service and replacement parts. Moline offers onsite design services to make your bearings stand out.



ENGINEERING AND MACHINING SERVICES

**Has the bearing you need been discontinued?
Is your customer experiencing bearing failure or broken housings?**

Moline Engineers are available to custom design or modify existing housings to resolve any design or operating issues you may encounter. We are available to help troubleshoot. Fast turnaround on small runs, along with low minimum quantities are our specialty.





- We offer specialty housing materials such as ductile iron or machined steel
- In many instances we can modify existing housings to suit a mounting issue or space consideration
- Moline's Engineering Department can reverse engineer discontinued mounted units
- Fast turnaround on small runs and low minimum quantities are our specialty
- We offer specialty seals and seal design solutions to suit a variety of application environments
- High-temp, Low-temp, Solid Lube, Food-Grade greases are available upon request
- Please call the factory for more information, pricing and availability



Product	Customer Problem	Moline Solution/Benefit
Stainless Steel Piloted Flange with Solid Lubricant	Customer sought to eliminate potential corrosion and contamination in a food processing environment.	Moline provided the complete solution with this stainless steel housing, insert and collars to the engineers specifications. We further specified a solid lubricant to ensure containment.



ENGINEERING AND MACHINING SERVICES

Product	Customer Problem	Moline Solution/Benefit
SealMaster SleeveLoc Discontinued by SealMaster	The customer had welded threaded bolts to their machines that only matched the discontinued Sealmaster 3000 flange unit.	Moline machined a steel flange housing with a matched the bolt pattern of the discontinued bearing. The customer was spared the high cost of reworking their existing machinery. 
Dodge B1 Double-Interlock	Customer purchased then performed additional modification of this Dodge cartridge unit.	Moline reverse engineered and performed additional machining within a three week period. The customer saved time and cost of additional machining. Bearing was not contaminated by secondary machining process. 
Browning 950 Discontinued by Browning	Customer designed their equipment around the discontinued Browning 950 pillow block. The bolt pattern and pad height were crucial dimensions.	Moline made a casting that matched dimensions and created a part that was less expensive than original unit. Customer did not have to redesign their equipment or create retrofit kit for existing machines. 
Type E 2-Bolt "Miz" Bearing	Standard cast iron housing was breaking and customer needed to order a small quantity.	Machined a steel housing that matched the bolt pattern with a quick turnaround and at a reasonable cost. 
Grab Roller Bearing #1	The original cast iron design of their agricultural bearing was breaking. An attempt to use a weldment also failed.	Moline provided this housing in ductile iron and increased the thickness of the bolt pad to allow a larger bolt thus decreasing the chance of housing failure. 

SPECIALTY SERVICES





Product	Customer Problem	Moline Solution/Benefit
<p>Grab Roller Bearing #2</p>	<p>Customer could not use traditional pillow block mounting due to space and extreme dirt environment. Bearing was failing due to constant dirt impaction.</p>	<p>Moline manufactured a steel housed unit with tapped base mounting. Machined the housing bore to provide space to install a double set of seals on both sides for increased protection.</p>





Product	Customer Problem	Moline Solution/Benefit
<p>Ball Bearing with Custom Steel Housing for an application in a tight and confined space.</p>	<p>Customer was experiencing broken housings and had limited space for mounting a larger bearing.</p>	<p>Moline custom designed, machined and manufactured steel housing with ER insert and custom locking channel.</p>

COATINGS AND FINISHES

When you need extra protection for your bearing, or have a unique operating environment, consider using one of our new specialty coatings for your mounted bearings.

Let us help you reduce costs by letting Moline handle your coating needs.

While we offer **moline+color** traditional powder coating services in a limitless range of colors, it does not stop there; High temp, Ceramic coatings, Heat dissipation, Stainless Steel powder coating, Anti-microbial epoxy, Nickel plating, Teflon coating and Marine grade coatings are available.

For your OEM customers. All of our coatings exceed customer specifications and requirements, resulting in longer life and a better end product. Custom matching of colors, including small batch runs are no issue. Our capabilities include custom formulations, custom colors, UV resistance, and corrosion protection.

Stainless Steel Coating

Moline can provide a patented stainless steel coating that is highly protective, anti-corrosive and so durable, it will handle high detergent/antibacterial wash downs commonly used in the food industry. Moline can offer an “antimicrobial” finish that is direct contact USDA/FDA Certified for food & consumables.

Specialty Coatings can provide longer bearing life

RAL or custom color matching is available

Reduce costs by letting Moline provide your custom painting or coatings

Protective Stainless Steel Powder Coatings for enhanced corrosion resistance



Stainless Powdercoat
Type E 4-Bolt Flange



SPECIALTY SERVICES

For personal service 800.242.4633
CAD drawings at no additional charge
For nomenclature see pages 226 and 227

MOLINE BEARING CO



END CAPS AND BEARING COVERS

Increase the life of your bearings by keeping them clean and free of debris with bearing end caps and bearing covers. Moline offers open and closed end caps, standard bearing covers, and extended shaft bearing covers for all stocked mounted units.

We can custom design to suit your specific needs for almost any operating environment. Fast turnaround on small runs and low minimum quantities are our specialty.

- Our covers are available in standard impact resistant black ABS plastic, other colors and materials also available
- Meets OSHA Safety Standards for all Mechanical Transmission Apparatus
- Specialty sealing, gasket and grease fitting options are offered
- **Heat and Chemical Resistant**- ABS is resistant to most chemical attacks and can withstand 200°F
- **Durable** - ABS and PETG covers will flex to absorb. They will never rust!
- **Sterilizable** - Plastic covers are especially useful in the pharmaceutical and food processing industries, and can be sterilized with steam and most detergent solutions
- **Outdoors Applications** - Both Black ABS and Transparent PETG will work in outdoor applications

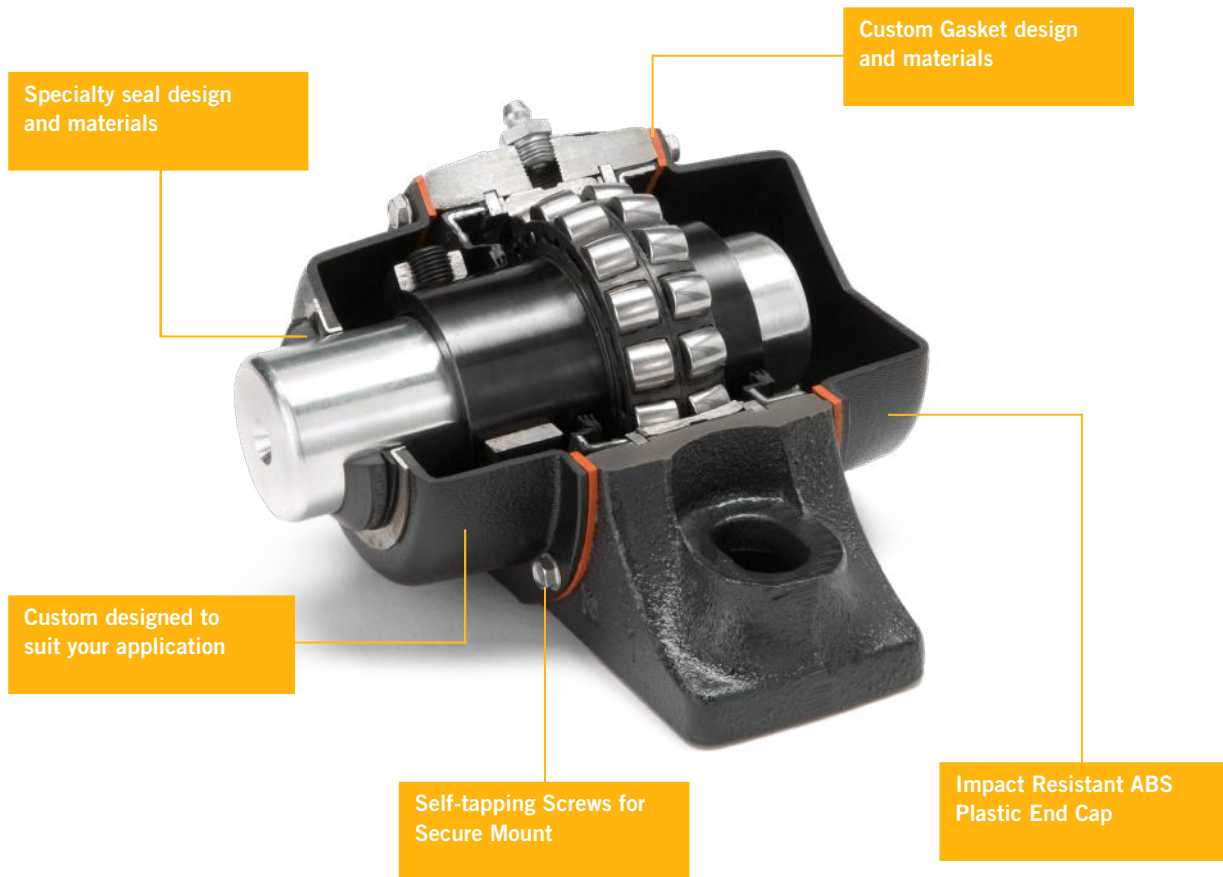

END CAPS AND BEARING COVERS

Our most commonly requested **End Caps** are the Open and Closed units pictured below and listed in the chart to the right.



For specific and specialty applications we have wide range of Caps and Covers in stock. Please call Moline to discuss solutions.



Closed and Open, Pillow Block Covers.



Closed, 4-Bolt Flange Cover



Pillow Block Cover with extended Shaft and Seal protection.

SHAFT SIZE	TYPE E OPEN CAP PART #	TYPE E CLOSED CAP PART #	SHAFT SIZE	M2000, ME2000 M3000, ME3000 OPEN CAP PART #	M2000, ME2000 M3000, ME3000 CLOSED CAP PART #
1	18601100	18600103	1	----	----
1 3/16	18601103	18600103	1 3/16	18621103	18620107
1 1/4	18601104	18600103	1 1/4	18621104	18620107
1 3/8	18621106	18620107	1 3/8	----	----
1 7/16	18621107	18620107	1 7/16	18621107	18620107
1 1/2	18601108	18620111	1 1/2	18621107	18620107
1 5/8	18601110	18620111	1 5/8	----	----
1 11/16	18621111	18620111	1 11/16	18621111	18620111
1 3/4	18601112	18620115	1 3/4	18621112	18620111
1 7/8	18601112	18620115	1 7/8	----	----
1 15/16	18621115	18620115	1 15/16	18621115	18620115
2	18621115	18620115	2	18621115	18620115
2 3/16	18621203	18620203	2 3/16	18621203	18620203
2 1/4	18601207	18620207	2 1/4	18621203	18620203
2 7/16	18621207	18620207	2 7/16	18621207	18620207
2 1/2	18621208	18620207	2 1/2	18621208	18620207
2 11/16	18621211	18620215	2 11/16	18621211	18620215
2 3/4	18621211	18620215	2 3/4	18621211	18620215
2 15/16	18621215	18620215	2 15/16	18621215	18620215
3	18621215	18620215	3	18621215	18620215
3 3/16	18621303	18600307	3 3/16	18621303	18620307
3 1/4	18621303	18600307	3 1/4	----	----
3 7/16	18621307	18620307	3 7/16	18621307	18620307
3 1/2	18621308	18620307	3 1/2	18621308	18620307
3 15/16	18601315	18600315	3 15/16	18621315	18620315
4	18601315	18600315	4	18621315	18620315
4 7/16	18601407	18600407	4 7/16	18621407	18620407
4 1/2	18601407	18600407	4 1/2	18621407	18620407
4 15/16	18601415	18600415	4 15/16	18621415	18620415
5	18601415	18600415	5	18621415	18620415
5 7/16	18601507	18600507			
5 1/2	18601507	18600507			
5 15/16	18601515	18600515			
6	18601515	18600515			
6 7/16	18601607	18600615			
6 1/2	18601608	18600615			
6 15/16	18601615	18600615			
7	18601615	18600615			

SPECIALTY SERVICES



LUBRICANTS

After choosing the best Moline Bearing unit for your application, make sure you specify the optimal grease for your application.

Moline offers a wide variety of Lubricants available on the market today. We offer high temp, low temp, cryogenic and food grade greases often at no additional charge. If you have specific performance requirements of the lubricant used for your application, please contact us with the details and we can help to determine which product and formula works best for your application. We will be glad to accommodate your request.

Timken® Premium All Purpose Industrial LC-2 Grease GR217 - Standard Bearing Grease

- NLGI No. 2 extreme pressure, lithium-complex thickened grease
- Solid protection against rust and corrosion
- Excellent protection against wear
- Applications: Ideal for industrial bearings operating at higher-than-average temperatures and/or subjected to shock loading

Timken® Mill Grease GR182 - High Temp Bearing Grease

- Calcium sulfonate-thickened grease
- Excellent resistance to water washout
- Superior protection against rust and corrosion, including salt spray
- Excellent high-temperature properties
- Timken Mill Grease is formulated with high VI parafinic mineral oil, resulting in very good oxidation stability
- Applications: Steel mills, paper mills, aluminum mills, foundries, cement plants, power generation, off-road applications, mineral processing, offshore rigs and marine applications

Timken® Food Safe Grease GR231 - Food Grade Bearing Grease

- NLGI No. 2 aluminum-complex thickened lubricating grease
- Provides for improved low- and high-temperature performance
- Contains extra-pressure, anti-wear additives and corrosion and oxidation inhibitors
- Applications: Food processing operations



LUBRICANTS

PhyMet® MicroPoly Solid Lubricant

- Creates a solid lubricant with an oil-filled porous structure
- MicroPoly fills the space between the rolling elements and races in a bearing, providing consistent lubrication
- There is no need for additional lubrication during the life of a MicroPoly filled bearing
- Because Phymet is a solid, MicroPoly can help block debris and reduce foreign contamination of the bearing.
- Reducing the incursion of debris into the bearing can significantly extend the bearing's life
- MicroPoly also improves housekeeping, as it will not drip out of the bearing and contaminate the environment
- Cuts downtime and maintenance costs
- Applications: Agriculture, fabrication, food and beverage, mining and lumber, paper and packaging, utilities
- MicroPoly offers a variety of solid lubricant formulas for industrial, high temp, high speed and food grade applications

Grease Type	Purpose	Application	Environment
Timken GR 217	Premium All purpose LC-2 Lithium Complex -40°C to 149°C -40°F to 300°F	Agriculture, Bushings/Ball Joints, Truck and Auto Wheel Bearings, Heavy Duty Industrial	High Wear, Moderate Loads, Moderate Speeds, Moderate Temperatures
Timken GR 182K	Mill Grease Calcium Suifonate -40°C to 204°C -40°F to 400°F	Aluminum Mills, Paper Mills, Steel Mills, Offshore Rigs, Power Generation	Corrosive Media, Extreme Heat, Heavy Loads, Wet Conditions, Slow to Moderate Speeds
Timken GR 231C	Food Safe Aluminum Complex -40°C to 149°C -40°F to 300°F	Food and Beverage Industries, Pharmaceuticals	Incidental Food Contact, Hot and Clod Temperatures, Moderate to High Speeds, Medium Loads
Phymet Micropoly MPI 0800	Premium All Purpose Solid Polymer -23°C to 93°C -10°F to 200°F	Agricultural, Automotive, Heavy Industrial, Printing	Severe and Hard to access and service areas, Low to Moderate Loads, Speeds and Temperatures



GREASE TAG PRIVATE LABEL BRANDING

You have worked hard to build your brand and we understand this. Take one step further by labeling our mounted units with your company's logo so that the end-user comes back to you for all service and replacement parts. A custom grease tag is a small step to greater brand marketing.

Moline offers onsite design services to make your bearings stand out, look good and help your customer find their way back to you for aftermarket sales. Contact us to discuss ways in which we can help your product stand out in a crowd.

SPECIALTY SERVICES



GREASE TAG PRIVATE LABEL BRANDING

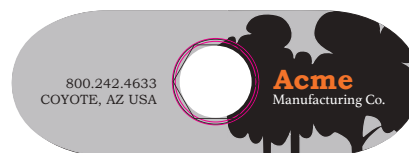
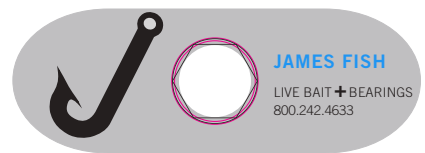
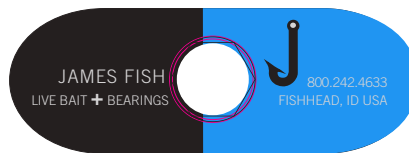
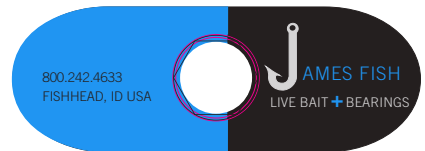
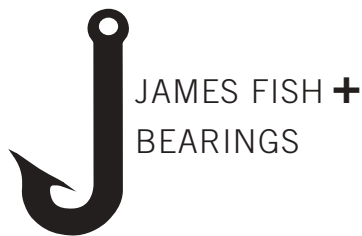
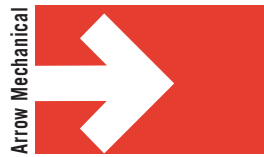

SPECIALTY SERVICES

For personal service 800.242.4633
 CAD drawings at no additional charge
 For nomenclature see pages 240 and 241

MOLINE BEARING CO.





BALL BEARINGS

Moline Mounted Ball Bearings consist of a single row deep groove ball bearing and cast iron housings. These are available in wide range of shaft sizes in 2-Bolt Pillow Blocks, 2-Bolt and 4-Bolt Flanges, Piloted Flange and Wide Slot Take-Up units.

The self-contained bearing with a spherical ground outside diameter is assembled into a corresponding spherical seat of the housing, providing full self-alignment of the bearing in the housing at mounting. Moline's Mounted Ball Bearings are supplied from the factory in shaft-ready condition.

The inner rings of the insert bearings are through hardened in the raceway, while the extended ring where the set screws are installed is metallurgically mild and softened. This unique heat treatment ensures full bearing performance and prevents the set screws from loosening during operation. Thus, the set screws can be tightened as needed without causing cracks on the inner ring.

We sell these bearings as inserts, housings and complete units.

All ball bearing housings come with a standard paint finish.

These Mounted Ball Bearings are carried in Moline warehouses and distributor stocks throughout the United States and in Canada.

They are manufactured overseas for Moline and meet a quality standard set by the bearing industry, except at a lower price point.

FEATURES OF MOLINE MOUNTED BALL BEARINGS

- For applications that require high speed, moderate load and some axial load
- Dimensionally interchangeable with comparable industry standard units
- Suggested Industry Applications: Conveying, Screening, Material Handling, Food and Beverage
- Available in sizes from ½" to 4"
- Available in normal duty set screw lock, normal duty eccentric lock and medium duty set screw lock
- Easy installation and maintenance
- Fully self-aligning
- Wide inner ring for rigidity and more effective set screw locking
- Standard grease fitting for re-lubrication
- Contact seals are standard
- Operating temperatures up to 200° F
- Single piece housings of Class 30 cast iron
- Housings available in the standard painted finish. Powder coating in RAL or custom colors, Stainless Steel Powder coating, Nickel-plating, Epoxy, Teflon and other coatings are available. See page 150 or contact the factory for further information
- Custom machining and design service are available. See page 146 or contact the factory for further information
- Available for sale as complete units, inserts and housings

NORMAL DUTY UC 2-BOLT PILLOW BLOCK

UCP 200 Series—Mounted Ball Bearing Set Screw Lock

SHAFT SIZE	MOLINE PART #	UNIT #	DYNAMIC CAPACITY LBS	DIMENSIONS (INCHES)				
				M	B	D	C	G
1/2	19421008	UCP 201-08	2878	1 5/16	5	3 3/4	1 1/2	5/8
5/8	19421010	UCP 202-10						
3/4	19421012	UCP 204-12						
7/8	19421014	UCP 205-14	3147	1 7/16	5 1/2	4 1/8	1 1/2	3/4
15/16	19421015	UCP 205-15						
1	19421100	UCP 205-16						
1 1/8	19421102	UCP 206-18	4384	1 11/16	6 1/4	4 3/4	1 3/4	3/4
1 3/16	19421103	UCP 206-19						
1 1/4	19421104-06	UCP 206-20						
1 1/4	19421104	UCP 207-20	5778	1 7/8	6 9/16	5	1 7/8	3/4
1 5/16	19421105	UCP 207-21						
1 3/8	19421106	UCP 207-22						
1 7/16	19421107	UCP 207-23						
1 1/2	19421108	UCP 208-24	6654	1 15/16	7 1/4	5 7/8	2	13/16
1 9/16	19421109	UCP 208-25						

For sale as complete units, inserts and housings.

BALL BEARINGS

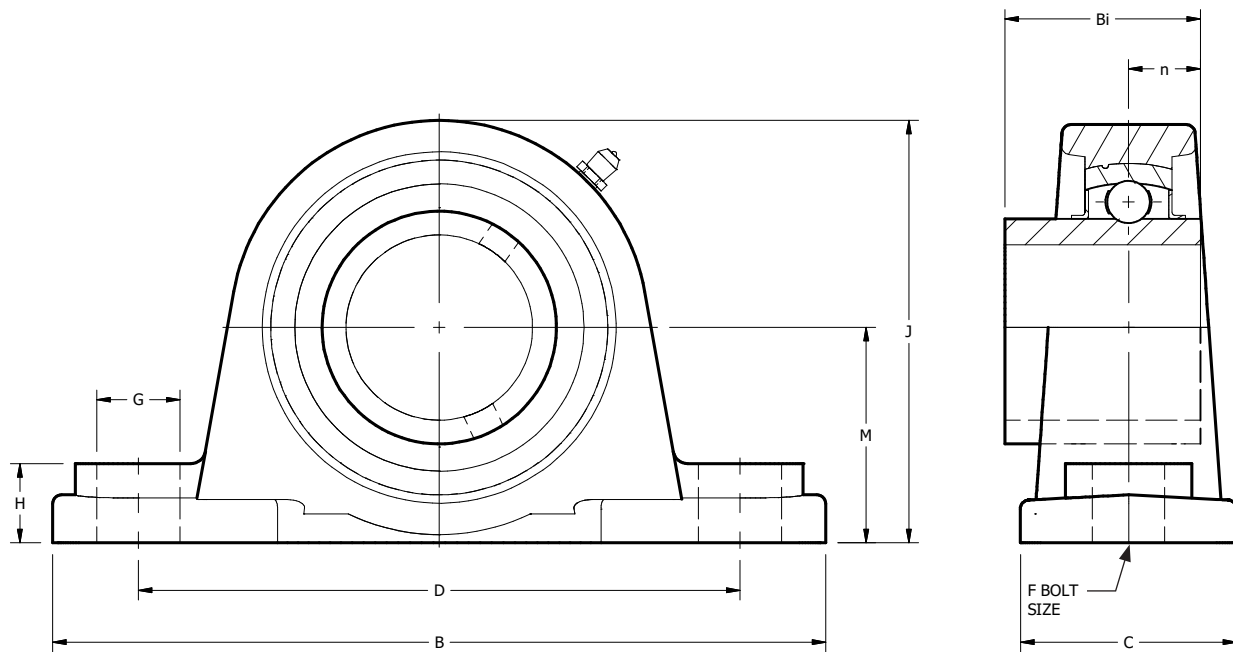

NORMAL DUTY UC 2-BOLT PILLOW BLOCK

SHAFT SIZE	DIMENSIONS (INCHES)					INSERT #	HOUSING #	WEIGHT LBS.
	H	J	Bi	n	F			
1/2 5/8 3/4	9/16	2 19/32	1.22	0.500	3/8	UC 201-08 UC 202-10 UC 204-12	P204	1.43
7/8 15/16 1	5/8	2 3/4	1.339	0.563	3/8	UC 205-14 UC 205-15 UC 205-16	P205	1.59
1 1/8 1 3/16 1 1/4	11/16	3 9/32	1.50	0.626	1/2	UC 206-18 UC 206-19 UC 206-20	P206	2.54
1 1/4 1 5/16 1 3/8 1 7/16	3/4	3 11/16	1.689	0.689	1/2	UC 207-20 UC 207-21 UC 207-22 UC 207-23	P207	3.37
1 1/2 1 9/16	13/16	3 15/16	1.937	0.748	1/2	UC 208-24 UC 208-25	P208	4.14



BALL BEARINGS

For personal service 800.242.4633
CAD drawings at no additional charge
For nomenclature see pages 240 and 241

MOLINE BEARING CO



NORMAL DUTY UC 2-BOLT PILLOW BLOCK CONTINUED

UCP 200 Series—Mounted Ball Bearing Set Screw Lock

SHAFT SIZE	MOLINE PART #	UNIT #	DYNAMIC CAPACITY LBS	DIMENSIONS (INCHES)				
				M	B	D	C	G
1 5/8	19421110	UCP 209-26	7160	2 1/8	7 1/2	5 3/4	2 1/8	1 3/16
1 11/16	19421111	UCP 209-27						
1 3/4	19421112	UCP 209-28						
1 7/8	19421114	UCP 210-30	7891	2 1/4	8 1/8	6 1/4	2 1/4	7/8
1 15/16	19421115	UCP 210-31						
2	19421200-10	UCP 210-32						
2	19421200	UCP 211-32	9790	2 1/2	8 5/8	6 7/8	2 3/8	7/8
2 1/8	19421202	UCP 211-34						
2 3/16	19421203	UCP 211-35						
2 1/4	19421204	UCP 212-36	10746	2 3/4	9 1/2	7 11/32	2 1/2	1
2 3/8	19421206	UCP 212-38						
2 7/16	19421207	UCP 212-39						
2 1/2	19421208	UCP 213-40	12859	3	10 7/16	8 1/8	2 11/16	1 1/8
2 3/4	19421212	UCP 214-44	13668	3 1/8	10 1/2	8 1/8	2 53/64	1 1/8
2 15/16	19421215	UCP 215-47	14837	3 1/4	10 13/16	8 1/2	2 15/16	1 1/8
3	19421300	UCP 215-48						
3 7/16	19421307	UCP 218-55	21559	4	12 7/8	10 5/16	3 15/32	1 3/16

For sale as complete units, inserts and housings.

BALL BEARINGS

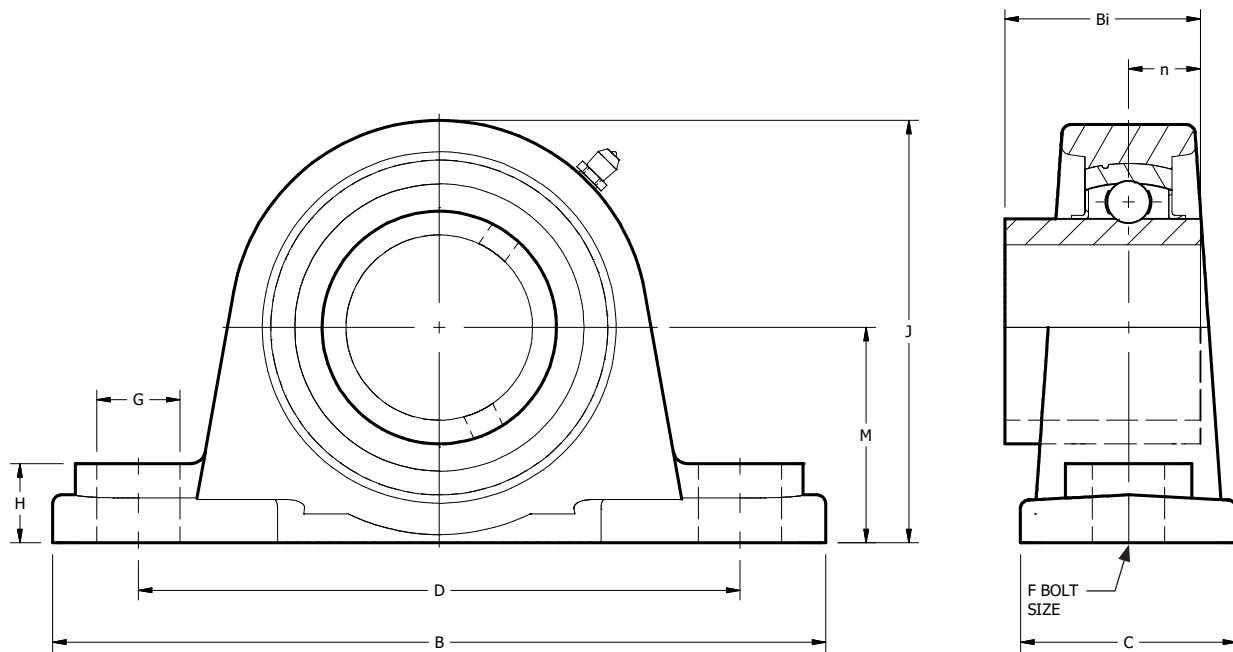

NORMAL DUTY UC 2-BOLT PILLOW BLOCK

SHAFT SIZE	DIMENSIONS (INCHES)					INSERT #	HOUSING #	WEIGHT LBS.
	H	J	Bi	n	F			
1 5/8 1 11/16 1 3/4	25/32	4 1/4	1.937	0.748	1/2	UC 209-26 UC 209-27 UC 209-28	P209	4.63
1 7/8 1 15/16 2	7/8	4 1/2	2.031	0.748	5/8	UC 210-30 UC 210-31 UC 210-32	P210	5.51
2 2 1/8 2 3/16	7/8	4 31/32	2.189	0.874	5/8	UC 211-32 UC 211-34 UC 211-35	P211	7.28
2 1/4 2 3/8 2 7/16	1	5 7/8	2.563	1.000	5/8	UC 212-36 UC 212-38 UC 212-39	P212	12.13
2 1/2	1 1/16	5 29/32	2.566	1.000	3/4	UC 213-40	P213	12.35
2 3/4	1 1/8	6 5/32	2.937	1.189	3/4	UC 214-44	P214	14.55
2 15/16 3	1 3/32	6 13/32	3.063	1.311	3/4	UC 215-47 UC 215-48	P215	16.09
3 7/16	1 1/4	7 7/8	3.780	1.563	7/8	UC 218-55	P218	32.40

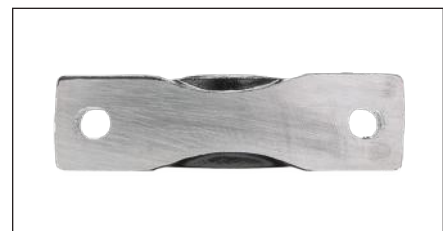

BALL BEARINGS

For personal service 800.242.4633
CAD drawings at no additional charge
For nomenclature see pages 240 and 241

MOLINE BEARING CO



NORMAL DUTY UC 2-BOLT FLANGE

UCFL 200 Series—Mounted Ball Bearing Set Screw Lock

SHAFT SIZE	MOLINE PART #	UNIT #	DYNAMIC CAPACITY LBS	DIMENSIONS (INCHES)					
				B	D	J	H	C	E
1/2	19401008	UCFL 201-08	2878	4 7/8	3 35/64	.591	.433	1	2 3/8
5/8	19401010	UCFL 202-10							
3/4	19401012	UCFL 204-12							
7/8	19401014	UCFL 205-14	3147	5 1/8	3 57/64	.630	.512	1 1/6	2 11/16
15/16	19401015	UCFL 205-15							
1	19401100	UCFL 205-16							
1 1/8	19401102	UCFL 206-18	4384	5 13/16	4 39/64	.709	.512	1 7/32	3 5/32
1 3/16	19401103	UCFL 206-19							
1 1/4	19401104-06	UCFL 206-20							
1 1/4	19401104	UCFL 207-20	5778	6 5/16	5 1/8	.748	.551	1 11/32	3 11/32
1 5/16	19401105	UCFL 207-21							
1 3/8	19401106	UCFL 207-22							
1 7/16	19401107	UCFL 207-23							
1 1/2	19401108	UCFL 208-24	6654	6 7/8	5 43/64	.827	.551	1 13/32	3 15/16
1 9/16	19401109	UCFL 208-25							
1 5/8	19401110	UCFL 209-26	7160	7 3/8	5 53/64	.866	.630	1 1/2	4 1/4
1 11/16	19401111	UCFL 209-27							
1 3/4	19401112	UCFL 209-28							

For sale as complete units, inserts and housings.

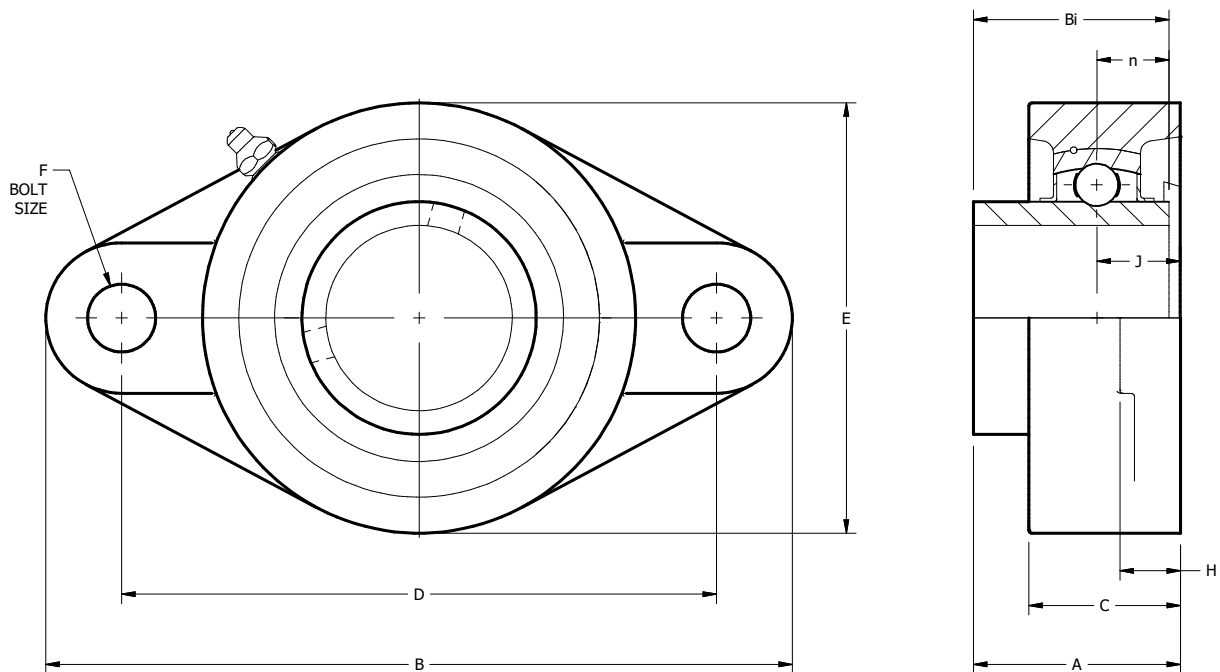

NORMAL DUTY UC 2-BOLT FLANGE

SHAFT SIZE	DIMENSIONS (INCHES)				INSERT #	HOUSING #	WEIGHT LBS.
	A	Bi	n	F			
1/2	1.311	1.220	0.500	3/8	UC 201-08	FL204	1.06
5/8					UC 202-10		
3/4					UC 204-12		
7/8	1.406	1.339	0.563	3/8	UC 205-14	FL205	1.43
15/16					UC 205-15		
1					UC 205-16		
1 1/8	1.583	1.500	0.626	3/8	UC 206-18	FL206	2.16
1 3/16					UC 206-19		
1 1/4					UC 206-20		
1 1/4	1.748	1.689	0.689	1/2	UC 207-20	FL207	2.76
1 5/16					UC 207-21		
1 3/8					UC 207-22		
1 7/16					UC 207-23		
1 1/2	2.016	1.937	0.748	1/2	UC 208-24	FL208	3.64
1 9/16					UC 208-25		
1 5/8	2.055	1.937	0.748	5/8	UC 209-26	FL209	4.30
1 11/16					UC 209-27		
1 3/4					UC 209-28		



BALL BEARINGS

For personal service 800.242.4633
 CAD drawings at no additional charge
 For nomenclature see pages 240 and 241

MOLINE BEARING CO.



NORMAL DUTY UC 2-BOLT FLANGE CONTINUED

UCFL 200 Series—Mounted Ball Bearing Set Screw Lock

SHAFT SIZE	MOLINE PART #	UNIT #	DYNAMIC CAPACITY LBS	DIMENSIONS (INCHES)					
				B	D	J	H	C	E
1 7/8	19401114	UCFL 210-30	7891	7 3/4	6 3/16	.866	.630	1.575	4 1/2
1 15/16	19401115	UCFL 210-31							
2	19401200-10	UCFL 210-32							
2	19401200	UCFL 211-32	9790	8 13/16	7 1/4	.984	.709	1.693	5 1/8
2 1/8	19401202	UCFL 211-34							
2 3/16	19401203	UCFL 211-35							
2 1/4	19401204	UCFL 212-36	10746	9 13/16	7 61/64	1.142	.709	1.890	5 1/2
2 3/8	19401206	UCFL 212-38							
2 7/16	19401207	UCFL 212-39							
2 1/2	19401208	UCFL 213-40	12859	10 13/16	8 17/64	1.181	.787	1.968	6 1/8
2 3/4	19401212	UCFL 214-44	13668	10 7/16	8 1/2	1.22	.787	2.126	6 5/16
2 15/16	19401215	UCFL 215-47	14837	10 13/16	8 55/64	1.339	.866	2.165	6 1/2
3	19401300	UCFL 215-48							
3 7/16	19401307	UCFL 218-55	21559	12 5/8	10 7/16	1.575	.906	2.677	8 1/16

For sale as complete units, inserts and housings.

BALL BEARINGS

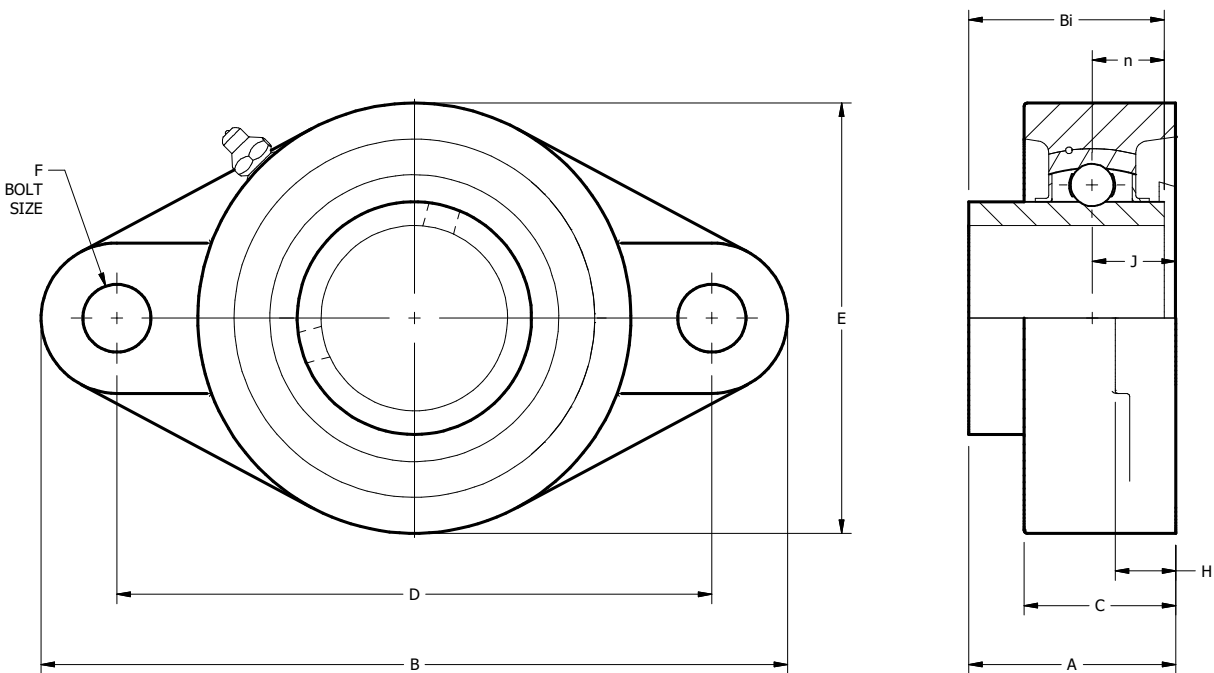

NORMAL DUTY UC 2-BOLT FLANGE

SHAFT SIZE	DIMENSIONS (INCHES)				INSERT #	HOUSING #	WEIGHT LBS.
	A	Bi	n	F			
1 7/8 1 15/16 2	2.150	2.031	0.748	5/8	UC 210-30 UC 210-31 UC 210-32	FL210	4.96
2 2 1/8 2 3/16	2.299	2.189	0.874	5/8	UC 211-32 UC 211-34 UC 211-35	FL211	7.27
2 1/4 2 3/8 2 7/16	2.705	2.563	1.00	5/8	UC 212-36 UC 212-38 UC 212-39	FL212	9.37
2 1/2	2.744	2.563	1.00	3/4	UC 213-40	FL213	11.68
2 3/4	2.969	2.937	1.189	3/4	UC 214-44	FL214	13.23
2 15/16 3	3.091	3.063	1.311	3/4	UC 215-47 UC 215-48	FL215	14.33
3 7/16	3.803	3.791	1.563	7/8	UC 218-55	FL218	27.33



BALL BEARINGS

For personal service 800.242.4633
CAD drawings at no additional charge
For nomenclature see pages 240 and 241

MOLINE BEARING CO.



NORMAL DUTY UC 4-BOLT FLANGE

UCF 200 Series—Mounted Ball Bearing Set Screw Lock

SHAFT SIZE	MOLINE PART #	UNIT #	DYNAMIC CAPACITY LBS	DIMENSIONS (INCHES)				
				B	D	J	H	C
1/2	19411008	UCF 201-08	2878	3 5/8	2 1/2	.591	1 5/32	1
5/8	19411010	UCF 202-10						
3/4	19411012	UCF 204-12						
7/8	19411014	UCF 205-14	3147	3 3/4	2 3/4	.630	9/16	1 1/16
1 5/16	19411015	UCF 205-15						
1	19411100	UCF 205-16						
1 1/8	19411102	UCF 206-18	4384	4 1/4	3 1/4	.709	9/16	1 9/32
1 3/16	19411103	UCF 206-19						
1 1/4	19411104-06	UCF 206-20						
1 1/4	19411104	UCF 207-20	5778	4 5/8	3 5/8	.748	5/8	1 11/32
1 5/16	19411105	UCF 207-21						
1 3/8	19411106	UCF 207-22						
1 7/16	19411107	UCF 207-23						
1 1/2	19411108	UCF 208-24	6654	5 1/8	4	.827	5/8	1 13/32
1 9/16	19411109	UCF 208-25						
1 5/8	19411110	UCF 209-26	7160	5 3/8	4 1/8	.866	23/32	1 1/2
1 11/16	19411111	UCF 209-27						
1 3/4	19411112	UCF 209-28						

For sale as complete units, inserts and housings.

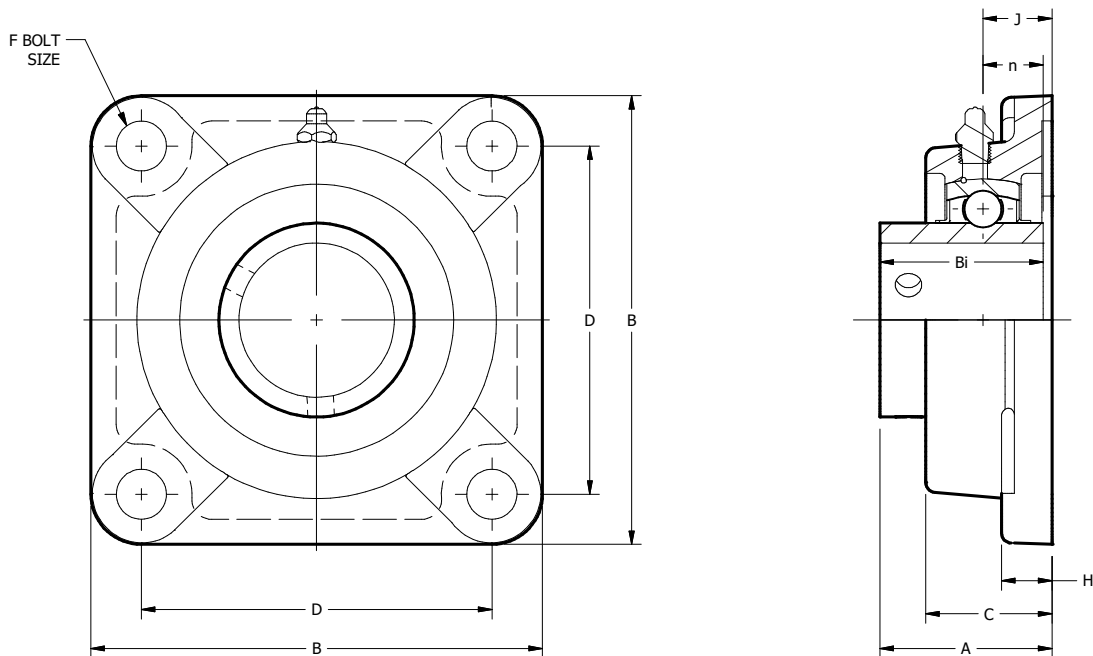

NORMAL DUTY UC 4-BOLT FLANGE

SHAFT SIZE	DIMENSIONS (INCHES)				INSERT #	HOUSING #	WEIGHT LBS.
	A	Bi	n	F			
1/2 5/8 3/4	1.311	1.22	0.500	3/8	UC 201-08 UC 202-10 UC 204-12	F204	1.35
7/8 15/16 1	1.406	1.339	0.563	3/8	UC 205-14 UC 205-15 UC 205-16	F205	1.76
1 1/8 1 3/16 1 1/4	1.583	1.500	0.626	3/8	UC 206-18 UC 206-19 UC 206-20	F206	2.36
1 1/4 1 5/16 1 3/8 1 7/16	1.748	1.689	0.689	1/2	UC 207-20 UC 207-21 UC 207-22 UC 207-23	F207	3.09
1 1/2 1 9/16	2.016	1.937	0.748	1/2	UC 208-24 UC 208-25	F208	3.97
1 5/8 1 11/16 1 3/4	2.055	1.937	0.748	1/2	UC 209-26 UC 209-27 UC 209-28	F209	4.85



BALL BEARINGS

For personal service 800.242.4633
 CAD drawings at no additional charge
 For nomenclature see pages 240 and 241

MOLINE BEARING CO



NORMAL DUTY UC 4-BOLT FLANGE CONTINUED

UCF 200 Series—Mounted Ball Bearing Set Screw Lock

SHAFT SIZE	MOLINE PART #	UNIT #	DYNAMIC CAPACITY LBS	DIMENSIONS (INCHES)				
				B	D	J	H	C
1 7/8	19411114	UCF 210-30	7891	5 5/8	4 3/8	.866	5/8	1.574
1 15/16	19411115	UCF 210-31						
2	19411200-10	UCF 210-32						
2	19411200	UCF 211-32	9790	6 3/8	5 1/8	.984	23/32	1.693
2 1/8	19411202	UCF 211-34						
2 3/16	19411203	UCF 211-35						
2 1/4	19411204	UCF 212-36	10746	6 7/8	5 5/8	1.142	23/32	1.890
2 3/8	19411206	UCF 212-38						
2 7/16	19411207	UCF 212-39						
2 1/2	19411208	UCF 213-40	12859	7 3/8	5 7/8	1.181	7/8	1.968
2 3/4	19411212	UCF 214-44	13668	7 3/8	5 7/8	1.220	29/32	2.125
2 15/16	19411215	UCF 215-47	14837	7 7/8	6 1/4	1.339	7/8	2.205
3	19411300	UCF 215-48						
3 7/16	19411307	UCF 218-55	21559	9 1/4	7 3/8	1.575	1 1/32	2.677

For sale as complete units, inserts and housings.

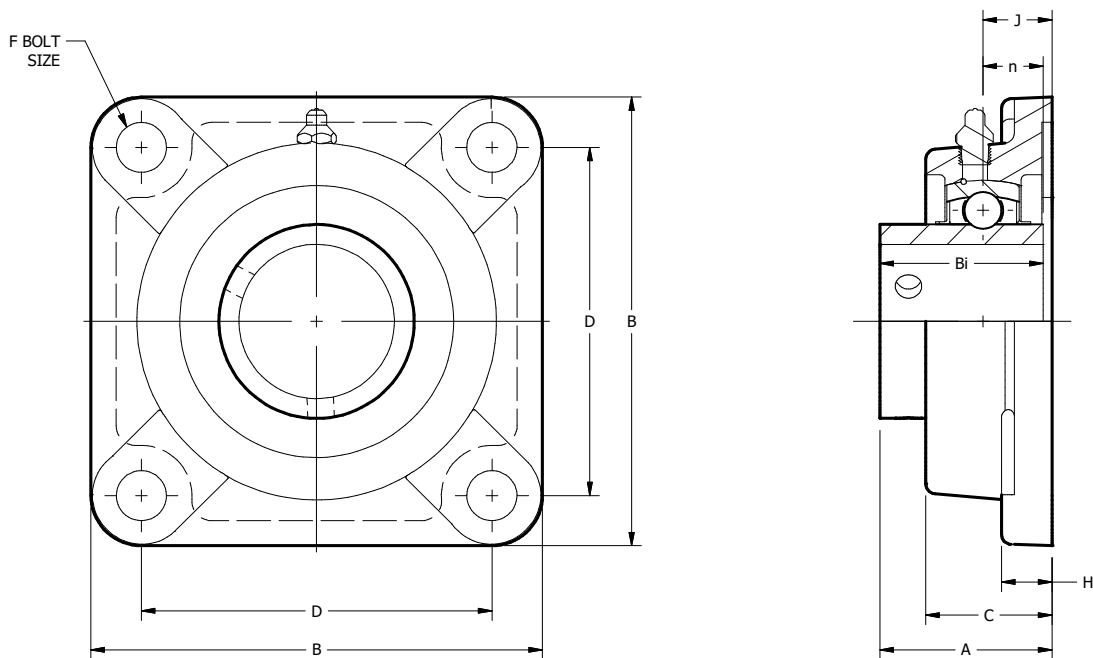

NORMAL DUTY UC 4-BOLT FLANGE

SHAFT SIZE	DIMENSIONS (INCHES)				INSERT #	HOUSING #	WEIGHT LBS.
	A	Bi	n	F			
1 7/8 1 15/16 2	2.150	2.031	0.748	1/2	UC 210-30 UC 210-31 UC 210-32	F210	5.29
2 2 1/8 2 3/16	2.299	2.189	0.874	5/8	UC 211-32 UC 211-34 UC 211-35	F211	7.27
2 1/4 2 3/8 2 7/16	2.705	2.563	1.000	5/8	UC 212-36 UC 212-38 UC 212-39	F212	9.26
2 1/2	2.744	2.563	1.000	5/8	UC 213-40	F213	11.68
2 3/4	2.969	2.937	1.189	5/8	UC 214-44	F214	13.01
2 15/16 3	3.091	3.063	1.311	5/8	UC 215-47 UC 215-48	F215	13.89
3 7/16	3.791	3.78	1.563	3/4	UC 218-55	F216	25.57



BALL BEARINGS

For personal service 800.242.4633
 CAD drawings at no additional charge
 For nomenclature see pages 240 and 241



NORMAL DUTY UC PILOTED FLANGE

UCFC 200 Series—Mounted Ball Bearing Set Screw Lock

SHAFT SIZE	MOLINE PART #	UNIT #	DYNAMIC CAPACITY LBS	DIMENSIONS (INCHES)					
				B	D	M	I	C	J
3/4	19431012	UCFC 204-12	2878	3 15/16	3 5/64	2.169	.394	1	.197
7/8	19431014	UCFC 205-14	3147	4 1/2	3 35/64	2.504	.394	1.063	.236
15/16	19431015	UCFC 205-15							
1	19431100	UCFC 205-16							
1 1/8	19431102	UCFC 206-18	4384	4 15/16	3 15/16	2.783	.394	1.220	.315
1 3/16	19431103	UCFC 206-19							
1 1/4	19431104-06	UCFC 206-20							
1 1/4	19431104	UCFC 207-20	5778	5 5/16	4 21/64	3.063	.433	1.338	.315
1 5/16	19431105	UCFC 207-21							
1 3/8	19431106	UCFC 207-22							
1 7/16	19431107	UCFC 207-23							
1 1/2	19431108	UCFC 208-24	6654	5 11/16	4 23/32	3.338	.433	1.417	.394
1 9/16	19431109	UCFC 208-25							

For sale as complete units, inserts and housings.

BALL BEARINGS

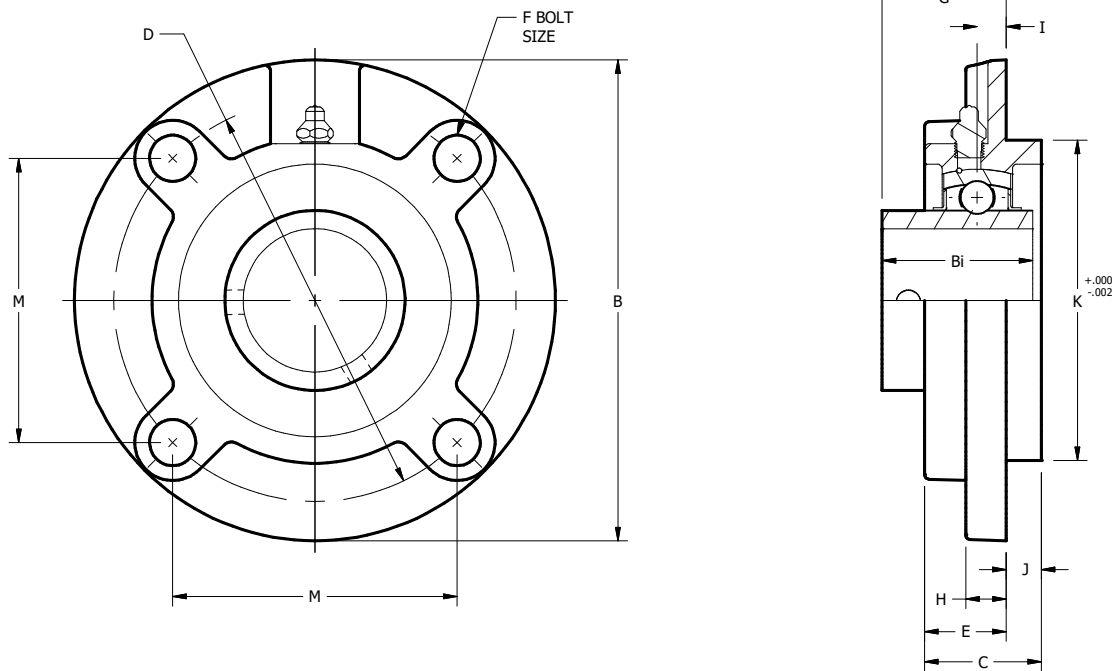

NORMAL DUTY UC PILOTED FLANGE

SHAFT SIZE	DIMENSIONS (INCHES)						INSERT #	HOUSING #	WEIGHT LBS.
	H	E	K	G	Bi	F			
3/4	9/32	.807	2.4409	1.114	1.2205	3/8	UC 204-12	FC204	1.68
7/8	9/32	.827	2.7559	1.169	1.3386	3/8	UC 205-14	FC205	2.12
15/16							UC 205-15		
1							UC 205-16		
1 1/8	5/16	.905	3.1496	1.268	1.50	3/8	UC 206-18	FC206	3.02
1 3/16							UC 206-19		
1 1/4							UC 206-20		
1 1/4	11/32	1.023	3.5433	1.433	1.689	7/16	UC 207-20	FC207	3.75
1 5/16							UC 207-21		
1 3/8							UC 207-22		
1 7/16							UC 207-23		
1 1/2	11/32	1.023	3.937	1.622	1.937	7/16	UC 208-24	FC208	4.41
1 9/16							UC 208-25		



BALL BEARINGS

For personal service 800.242.4633
 CAD drawings at no additional charge
 For nomenclature see pages 240 and 241

MOLINE BEARING CO.



NORMAL DUTY UC PILOTED FLANGE CONTINUED

UCFC 200 Series—Mounted Ball Bearing Set Screw Lock

SHAFT SIZE	MOLINE PART #	UNIT #	DYNAMIC CAPACITY LBS	DIMENSIONS (INCHES)					
				B	D	M	I	C	J
1 5/8	19431110	UCFC 209-26	7160	6 3/8	5 13/64	3.673	.394	1.496	.472
1 11/16	19431111	UCFC 209-27							
1 3/4	19431112	UCFC 209-28							
1 7/8	19431114	UCFC 210-30	7891	6 1/2	5 7/16	3.842	.394	1.575	.472
1 15/16	19431115	UCFC 210-31							
2	19431200-10	UCFC 210-32							
2	19431200	UCFC 211-32	9790	7 5/16	5 29/32	4.177	.512	1.653	.472
2 1/8	19431202	UCFC 211-34							
2 3/16	19431203	UCFC 211-35							
2 1/4	19431204	UCFC 212-36	10746	7 11/16	6 19/64	4.453	.669	1.890	.472
2 3/8	19431206	UCFC 212-38							
2 7/16	19431207	UCFC 212-39							
2 1/2	19431208	UCFC 213-40	12859	8 1/16	6 11/16	4.732	.630	1.929	.551
2 3/4	19431212	UCFC 214-44	13668	8 15/32	6 31/32	4.925	.669	2.126	.551
2 15/16	19431215	UCFC 215-47	14837	8 21/32	7 1/4	5.122	.669	2.165	.630
3	19431300	UCFC 215-48							

For sale as complete units, inserts and housings.

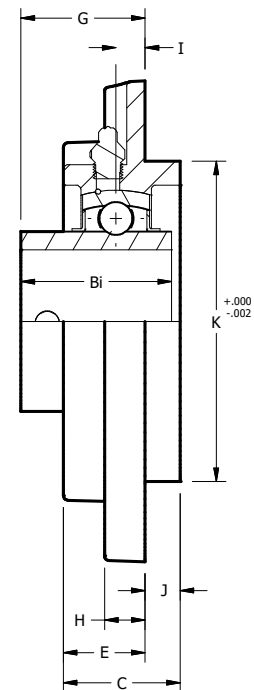
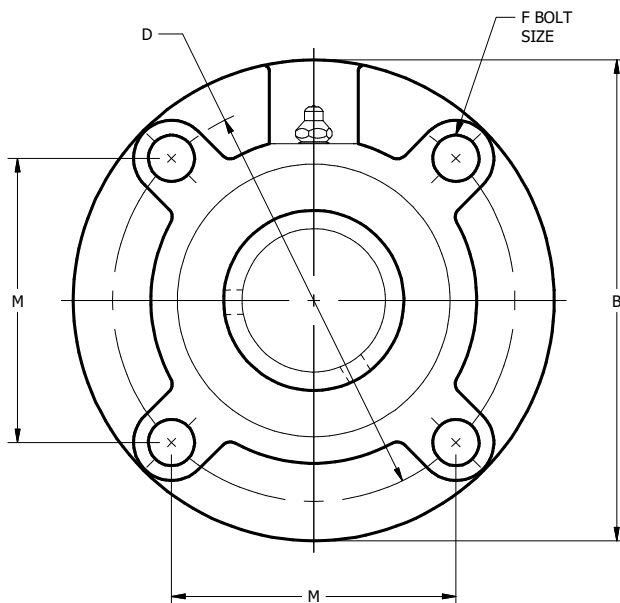

NORMAL DUTY UC PILOTED FLANGE

SHAFT SIZE	DIMENSIONS (INCHES)						INSERT #	HOUSING #	WEIGHT LBS.
	H	E	K	G	Bi	F			
1 5/8 1 11/16 1 3/4	35/64	1.023	4.1339	1.583	1.937	1/2	UC 209-26 UC 209-27 UC 209-28	FC209	5.95
1 7/8 1 15/16 2	35/64	1.102	4.3307	1.677	2.031	1/2	UC 210-30 UC 210-31 UC 210-32	FC210	6.39
2 2 1/8 2 3/16	19/32	1.181	4.9213	1.827	2.189	5/8	UC 211-32 UC 211-34 UC 211-35	FC211	9.26
2 1/4 2 3/8 2 7/16	19/32	1.417	5.315	2.232	2.563	5/8	UC 212-36 UC 212-38 UC 212-39	FC212	10.89
2 1/2	19/32	1.378	5.709	2.193	2.563	5/8	UC 213-40	FC213	12.57
2 3/4	23/32	1.496	5.905	2.417	2.937	5/8	UC 214-44	FC214	14.99
2 15/16 3	23/32	1.535	6.2992	2.461	3.063	5/8	UC 215-47 UC 215-48	FC215	29.76



BALL BEARINGS

For personal service 800.242.4633
CAD drawings at no additional charge
For nomenclature see pages 240 and 241

MOLINE BEARING CO.



NORMAL DUTY UC WIDE SLOT TAKE-UP

UCT 200 Series—Mounted Ball Bearing Set Screw Lock

SHAFT SIZE	MOLINE PART #	UNIT #	DYNAMIC CAPACITY LBS	DIMENSIONS (INCHES)						
				H	G	J	K	F	D	C
1/2	19451008	UCT 201-08	2878	5/8	3/8	2	1 1/4	5/8	2	15/32
5/8	19451010	UCT 202-10								
3/4	19451012	UCT 204-12								
7/8	19451014	UCT 205-14	3147	5/8	3/8	2	1 1/4	5/8	2	15/32
15/16	19451015	UCT 205-15								
1	19451100	UCT 205-16								
1 1/8	19451102	UCT 206-18	4384	5/8	3/8	2 3/16	1 7/16	3/4	2 1/4	15/32
1 3/16	19451103	UCT 206-19								
1 1/4	19451104-06	UCT 206-20								
1 1/4	19451104	UCT 207-20	5778	5/8	1/2	2 1/2	1 7/16	3/4	2 1/2	15/32
1 5/16	19451105	UCT 207-21								
1 3/8	19451106	UCT 207-22								
1 7/16	19451107	UCT 207-23								
1 1/2	19451108	UCT 208-24	6654	3/4	5/8	3 1/4	1 15/16	1	3 1/4	5/8
1 9/16	19451109	UCT 208-25								

For sale as complete units, inserts and housings.

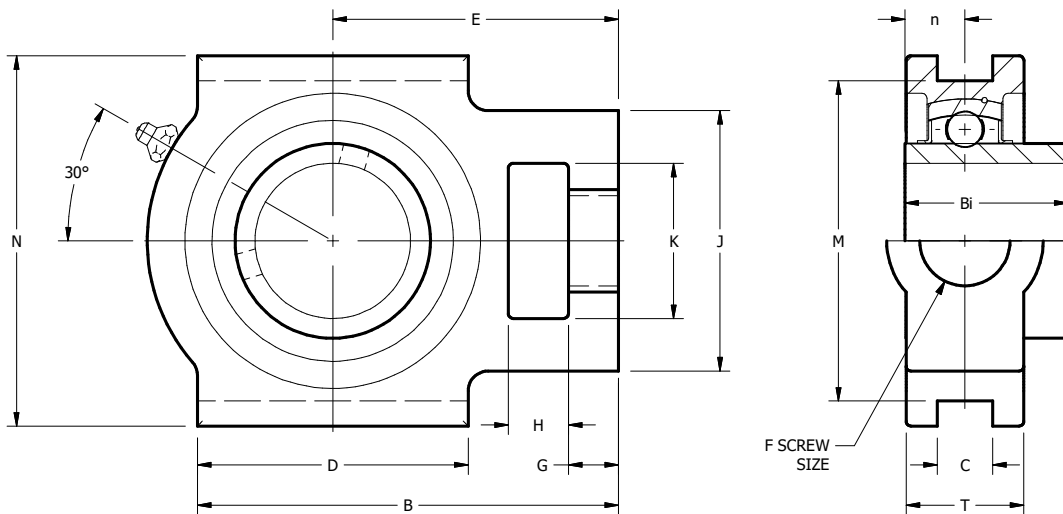

NORMAL DUTY UC WIDE SLOT TAKE-UP

SHAFT SIZE	DIMENSIONS (INCHES)							INSERT #	HOUSING #	WEIGHT LBS.
	M	N	B	T	E	Bi	n			
1/2 5/8 3/4	3	3 1/2	3 11/16	13/16	2 3/8	1.220	.550	UC 201-08 UC 202-10 UC 204-12	T204	1.85
7/8 15/16 1	3	3 1/2	3 13/16	15/16	2 7/16	1.339	.563	UC 205-14 UC 205-15 UC 205-16	T205	1.76
1 1/8 1 3/16 1 1/4	3 1/2	4	4 7/16	1 3/32	2 3/4	1.500	.626	UC 206-18 UC 206-19 UC 206-20	T206	2.42
1 1/4 1 5/16 1 3/8 1 7/16	3 1/2	4	5 1/16	1 3/16	3 1/16	1.689	.689	UC 207-20 UC 207-21 UC 207-22 UC 207-23	T207	3.53
1 1/2 1 9/16	4	4 1/2	5 11/16	1 5/16	3 1/2	1.937	.748	UC 208-24 UC 208-25	T208	5.51



BALL BEARINGS

For personal service 800.242.4633
CAD drawings at no additional charge
For nomenclature see pages 240 and 241

MOLINE BEARING CO



NORMAL DUTY UC WIDE SLOT TAKE-UP CONTINUED

UCT 200 Series—Mounted Ball Bearing Set Screw Lock

SHAFT SIZE	MOLINE PART #	UNIT #	DYNAMIC CAPACITY LBS	DIMENSIONS (INCHES)						
				H	G	J	K	F	D	C
1 5/8	19451110	UCT 209-26	7160	3/4	5/8	3 1/4	1 15/16	1	3 1/4	5/8
1 11/16	19451111	UCT 209-27								
1 3/4	19451112	UCT 209-28								
1 7/8	19451114	UCT 210-30	7891	3/4	5/8	3 1/4	1 15/16	1	3 3/8	1 1/16
1 15/16	19451115	UCT 210-31								
2	19451200-10	UCT 210-32								
2	19451200	UCT 211-32	9790	1	3/4	4	2 1/2	1 1/4	3 3/4	1 1/16
2 1/8	19451202	UCT 211-34								
2 3/16	19451203	UCT 211-35								
2 1/4	19451204	UCT 212-36	10746	1 1/4	3/4	4	2 1/2	1 1/4	4	1 1/16
2 3/8	19451206	UCT 212-38								
2 7/16	19451207	UCT 212-39								
2 1/2	19451208	UCT 213-40	12859	1 1/4	13/16	4 3/8	2 3/4	1 1/2	4 3/4	1 1/32
2 3/4	19451212	UCT 214-44								
2 15/16	19451215	UCT 215-47	14837	1 1/4	13/16	4 3/8	2 3/4	1 1/2	4 3/4	1 1/32
3	19451300	UCT 215-48								

For sale as complete units, inserts and housings.

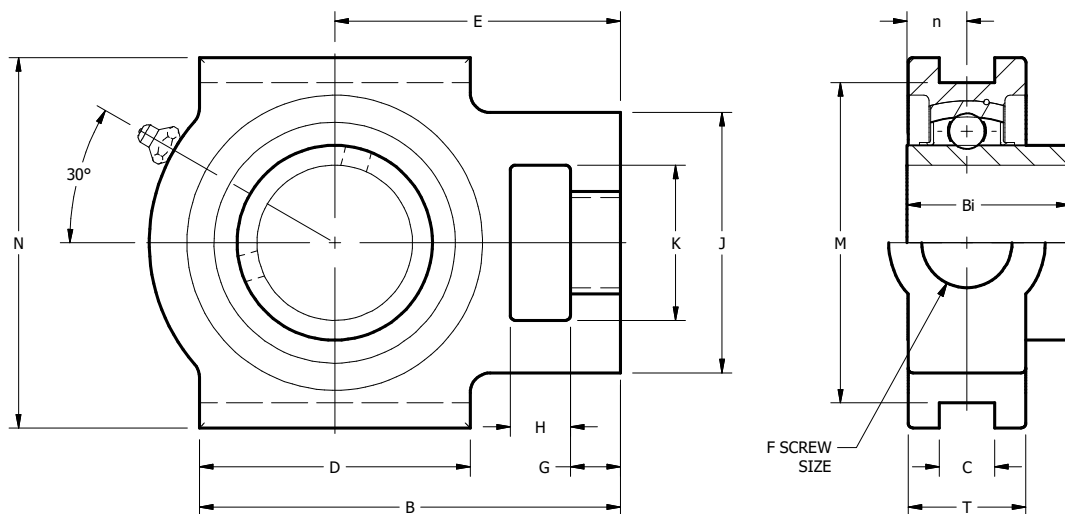

BALL BEARINGS



NORMAL DUTY UC WIDE SLOT TAKE-UP

SHAFT SIZE	DIMENSIONS (INCHES)							INSERT #	HOUSING #	WEIGHT LBS.
	M	N	B	T	E	Bi	n			
1 5/8 1 11/16 1 3/4	4	4 5/8	5 11/16	1 3/8	3 7/16	1.937	.748	UC 209-26 UC 209-27 UC 209-28	T209	5.29
1 7/8 1 15/16 2	4	4 5/8	5 7/8	1 15/32	3 9/16	2.031	.748	UC 210-30 UC 210-31 UC 210-32	T210	5.29
2 2 1/8 2 3/16	5 1/8	5 3/4	6 3/4	1 1/2	4 3/16	2.189	.874	UC 211-32 UC 211-34 UC 211-35	T211	9.04
2 1/4 2 3/8 2 7/16	5 1/8	5 3/4	7 5/8	1 21/32	4 11/16	2.563	1.000	UC 212-36 UC 212-38 UC 212-39	T212	11.02
2 1/2	5 15/16	6 9/16	8 13/16	1 3/4	5 3/8	2.563	1.000	UC 213-40	T213	15.43
2 3/4	5 15/16	6 9/16	8 13/16	1 13/16	5 3/8	2.937	1.189	UC 214-44	T214	15.65
2 15/16 3	5 15/16	6 9/16	9 1/8	1 7/8	5 1/2	3.062	1.311	UC 215-47 UC 215-48	T215	16.50



BALL BEARINGS

For personal service 800.242.4633
CAD drawings at no additional charge
For nomenclature see pages 240 and 241

MOLINE BEARING CO



NORMAL DUTY UC 200 SERIES INSERT

SHAFT SIZE	MOLINE PART #	UNIT #	DIMENSIONS (INCHES)							WEIGHT LBS.
			D	Bi	Be	n	m	G	ds	
1/2	15400008	UC 201-08								.45
5/8	15400010	UC 202-10	1.8504	1.221	.630	.500	.721	.185	1/4-28	.40
3/4	15400012	UC 204-12								.35
7/8	15400014	UC 205-14								.50
15/16	15400015	UC 205-15	2.0472	1.339	.669	.563	.776	.217	1/4-28	.45
1	15400100	UC 205-16								.40
1 1/8	15400102	UC 206-18								.75
1 3/16	15400103	UC 206-19	2.4409	1.500	.748	.626	.874	.217	1/4-28	.70
1 1/4	15400104-06	UC 206-20								.65
1 1/4	15400104	UC 207-20								1.15
1 5/16	15400105	UC 207-21	2.8346	1.689	.787	.689	1.000	.228	5/16-24	1.10
1 3/8	15400106	UC 207-22								1.00
1 7/16	15400107	UC 207-23								.95
1 1/2	15400108	UC 208-24	3.1496	1.937	.827	.748	1.189	.315	5/16-24	1.45
1 9/16	15400109	UC 208-25								1.40
1 5/8	15400110	UC 209-26								1.70
1 11/16	15400111	UC 209-27	3.3465	1.937	.866	.748	1.189	.315	5/16-24	1.60
1 3/4	15400112	UC 209-28								1.50
1 7/8	15400114	UC 210-30								1.85
1 15/16	15400115	UC 210-31	3.5433	2.032	.906	.748	1.284	.354	3/8-24	1.75
2	15400200-10	UC 210-32								1.60
2	15400200	UC 211-32								2.60
2 1/8	15400202	UC 211-34	3.9370	2.189	.984	.874	1.315	.354	3/8-24	2.45
2 3/16	15400203	UC 211-35								2.20
2 1/4	15400204	UC 212-36								3.60
2 3/8	15400206	UC 212-38	4.3307	2.563	1.063	1.000	1.563	.413	3/8-24	3.05
2 7/16	15400207	UC 212-39								2.85
2 1/2	15400208	UC 213-40	4.7244	2.563	1.102	1.000	1.563	.472	3/8-24	4.05
2 3/4	15400212	UC 214-44	4.9213	2.937	1.181	1.189	1.748	.472	1/2-20	4.45
2 15/16	15400215	UC 215-47								5.15
3	15400300	UC 215-48	5.1181	3.063	1.181	1.311	1.752	.472	1/2-20	4.40
3 7/16	15400307	UC 218-55	6.2990	3.780	1.457	1.563	2.217	.551	1/2-20	9.90

BALL BEARINGS



NORMAL DUTY UC 200 SERIES INSERT

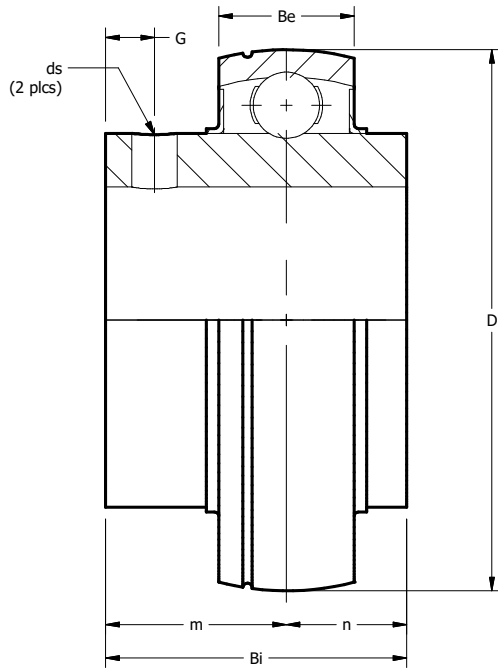

BALL BEARINGS

For personal service 800.242.4633
CAD drawings at no additional charge
For nomenclature see pages 240 and 241

MOLINE BEARING CO



NORMAL DUTY HC 2-BOLT PILLOW BLOCK

HCP 200 Series—Mounted Ball Bearing Eccentric Set Screw Locking Collar

SHAFT SIZE	MOLINE PART #	UNIT #	DYNAMIC CAPACITY LBS	DIMENSIONS (INCHES)				
				M	B	D	C	G
3/4	19521012	HCP 204-12	2878	1 5/16	5	3 3/4	1 1/2	5/8
7/8	19521014	HCP 205-14	3147	1 7/16	5 1/2	4 1/8	1 1/2	3/4
1 5/16	19521015	HCP 205-15						
1	19521100	HCP 205-16						
1 1/8	19521102	HCP 206-18	4384	1 11/16	6 1/4	4 3/4	1 3/4	3/4
1 3/16	19521103	HCP 206-19						
1 1/4	19521104-06	HCP 206-20						
1 1/4	19521104	HCP 207-20	5778	1 7/8	6 9/16	5	1 7/8	3/4
1 5/16	19521105	HCP 207-21						
1 3/8	19521106	HCP 207-22						
1 7/16	19521107	HCP 207-23						
1 1/2	19521108	HCP 208-24	6654	1 15/16	7 1/4	5 7/16	2	1 3/16
1 9/16	19521109	HCP 208-25						
1 5/8	19521110	HCP 209-26	7160	2 1/8	7 1/2	5 3/4	2 1/8	1 3/16
1 11/16	19521111	HCP 209-27						
1 3/4	19521112	HCP 209-28						

For sale as complete units, inserts and housings.

BALL BEARINGS

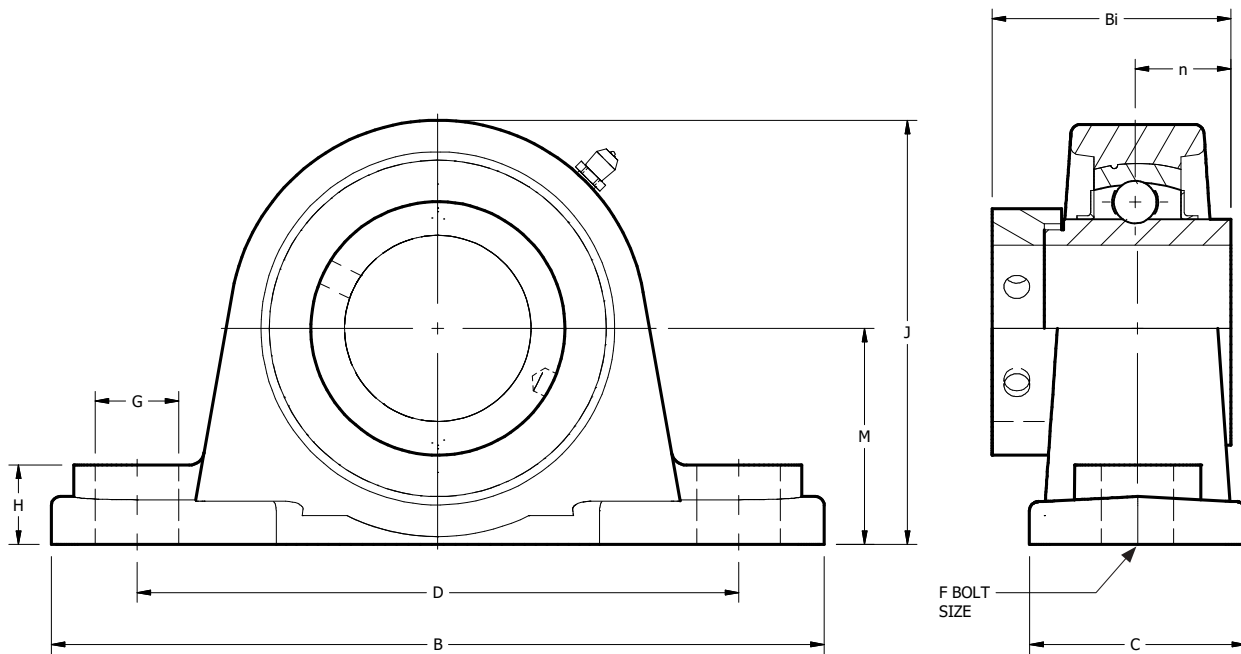

NORMAL DUTY HC 2-BOLT PILLOW BLOCK

SHAFT SIZE	DIMENSIONS (INCHES)					INSERT #	HOUSING #	WEIGHT LBS.
	H	J	Bi	n	F			
3/4	9/16	2 19/32	1.713	0.669	3/8	HC 204-12	P204	1.59
7/8 15/16 1	5/8	2 3/4	1.744	0.685	3/8	HC 205-14 HC 205-15 HC 205-16	P205	1.76
1 1/8 1 3/16 1 1/4	11/16	3 3/2	1.901	0.626	1/2	HC 206-18 HC 206-19 HC 206-20	P206	2.98
1 1/4 1 5/16 1 3/8 1 7/16	3/4	3 11/16	2.012	0.740	1/2	HC 207-20 HC 207-21 HC 207-22 HC 207-23	P207	3.75
1 1/2 1 9/16	13/16	3 15/16	2.216	0.842	1/2	HC 208-24 HC 208-25	P208	4.41
1 5/8 1 11/16 1 3/4	25/32	4 1/4	2.216	0.842	1/2	HC 209-26 HC 209-27 HC 209-28	P209	5.34



BALL BEARINGS

For personal service 800.242.4633
CAD drawings at no additional charge
For nomenclature see pages 240 and 241

MOLINE BEARING CO



NORMAL DUTY HC 2-BOLT PILLOW BLOCK CONTINUED

HCP 200 Series—Mounted Ball Bearing Eccentric Set Screw Locking Collar

SHAFT SIZE	MOLINE PART #	UNIT #	DYNAMIC CAPACITY LBS	DIMENSIONS (INCHES)				
				M	B	D	C	G
1 7/8	19521114	HCP 210-30	7891	2 1/4	8 1/32	6 1/4	2 1/4	7/8
1 15/16	19521115	HCP 210-31						
2	19521200-10	HCP 210-32						
2	19521200	HCP 211-32	9790	2 1/2	8 5/8	7	2 3/8	7/8
2 1/8	19521202	HCP 211-34						
2 3/16	19521203	HCP 211-35						
2 1/4	19521204	HCP 212-36	10746	2 3/4	9 7/16	7 3/8	2 1/2	1
2 3/8	19521206	HCP 212-38						
2 7/16	19521207	HCP 212-39						
2 1/2	19521208	HCP 213-40	12859	3	10 7/16	7 5/8	2 3/4	1 1/8
2 3/4	19521212	HCP 214-44	13668	3 1/8	10 1/2	8 17/64	2 53/64	1 1/8
2 15/16	19521215	HCP 215-47	14837	3 1/4	10 13/16	8 1/2	2 15/16	1 1/8
3	19521300	HCP 215-48						

For sale as complete units, inserts and housings.

BALL BEARINGS

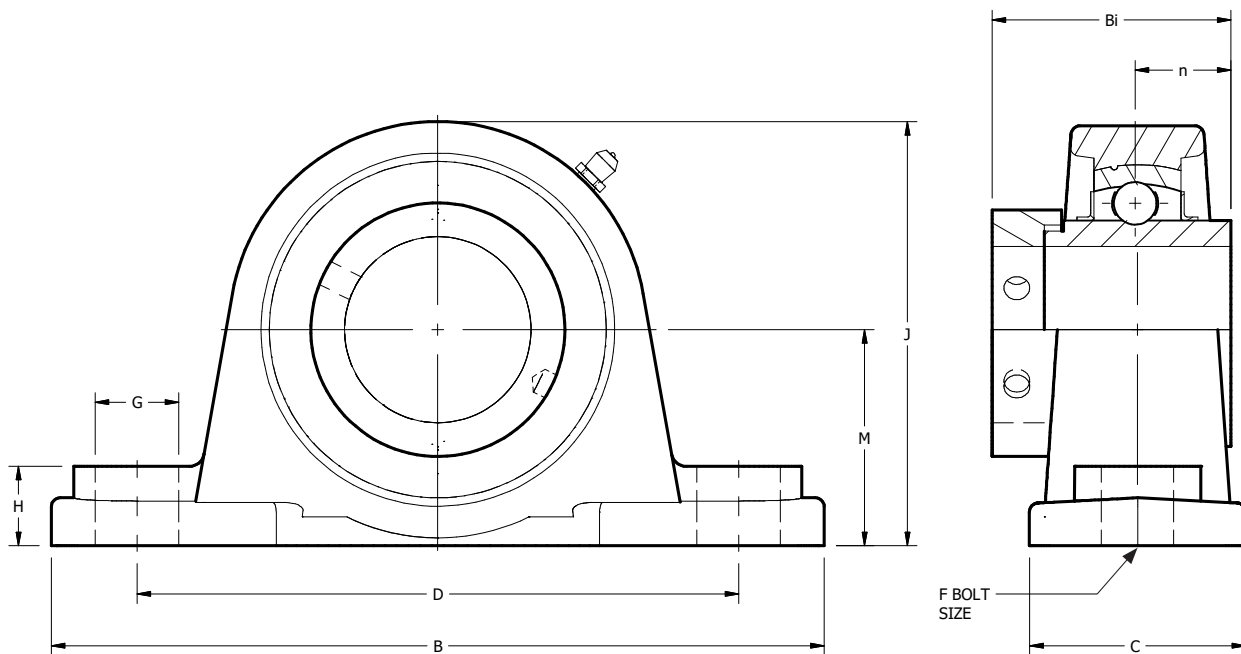

NORMAL DUTY HC 2-BOLT PILLOW BLOCK

SHAFT SIZE	DIMENSIONS (INCHES)					INSERT #	HOUSING #	WEIGHT LBS.
	H	J	Bi	n	F			
1 7/8 1 15/16 2	7/8	4 1/2	2.468	0.968	5/8	HC 210-30 HC 210-31 HC 210-32	P210	6.06
2 2 1/8 2 3/16	7/8	4 31/32	2.811	1.090	5/8	HC 211-32 HC 211-34 HC 211-35	P211	7.85
2 1/4 2 3/8 2 7/16	1	5 7/8	3.063	1.216	5/8	HC 212-36 HC 212-38 HC 212-39	P212	11.46
2 1/2	1 1/16	5 29/32	3.374	1.342	3/4	HC 213-40	P213	13.89
2 3/4	1 11/16	6 5/32	3.374	1.342	3/4	HC 214-44	P214	15.43
2 15/16 3	1 3/32	6 13/32	3.626	1.468	3/4	HC 215-47 HC 215-48	P215	17.20



BALL BEARINGS

For personal service 800.242.4633
CAD drawings at no additional charge
For nomenclature see pages 240 and 241

MOLINE BEARING CO



NORMAL DUTY HC 2-BOLT FLANGE

HCFL 200 Series—Mounted Ball Bearing Eccentric Set Screw Locking Collar

SHAFT SIZE	MOLINE PART #	UNIT #	DYNAMIC CAPACITY LBS	DIMENSIONS (INCHES)				
				B	D	J	H	C
3/4	19501012	HCFL 204-12	2878	4 7/8	3 39/64	.591	.433	1 5/32
7/8	19501014	HCFL 205-14	3147	5 1/8	3 57/64	.630	.512	1 7/32
1 5/16	19501015	HCFL 205-15						
1	19501100	HCFL 205-16						
1 1/8	19501102	HCFL 206-18	4384	5 13/16	4 39/64	.709	.512	1 11/32
1 3/16	19501103	HCFL 206-19						
1 1/4	19501104-06	HCFL 206-20						
1 1/4	19501104	HCFL 207-20	5778	6 5/16	5 1/8	.748	.551	1 7/16
1 5/16	19501105	HCFL 207-21						
1 3/8	19501106	HCFL 207-22						
1 7/16	19501107	HCFL 207-23						
1 1/2	19501108	HCFL 208-24	6654	6 7/8	5 43/64	.827	.551	1 17/32
1 9/16	19501109	HCFL 208-25						
1 5/8	19501110	HCFL 209-26	7160	7 3/8	5 53/64	.866	.630	1 9/16
1 11/16	19501111	HCFL 209-27						
1 3/4	19501112	HCFL 209-28						

For sale as complete units, inserts and housings.

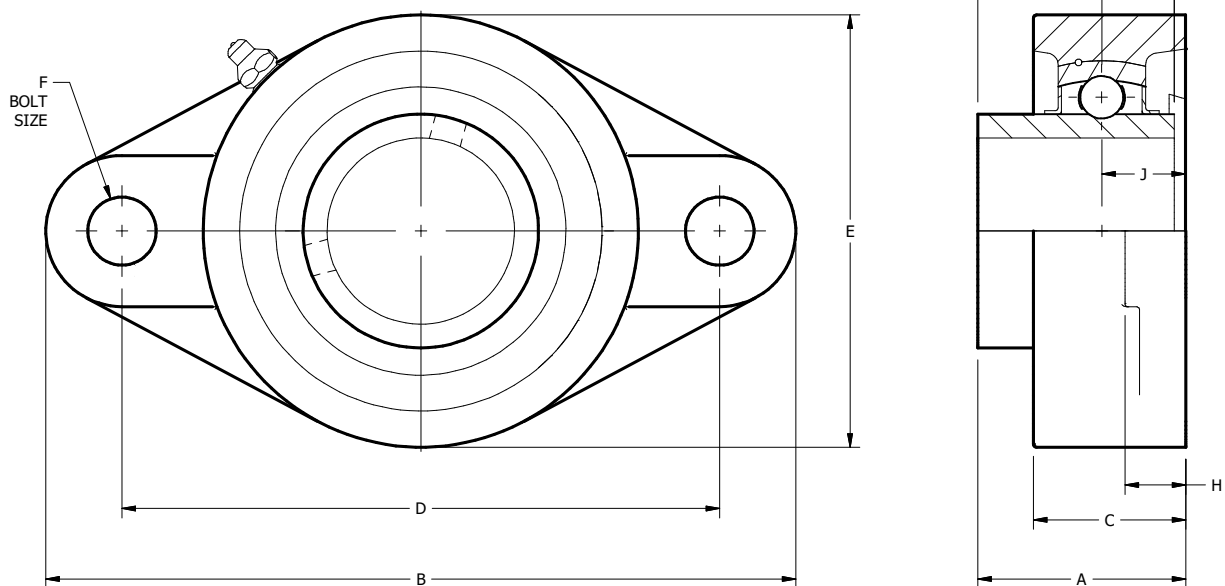

BALL BEARINGS



NORMAL DUTY HC 2-BOLT FLANGE

SHAFT SIZE	DIMENSIONS (INCHES)					INSERT #	HOUSING #	WEIGHT LBS.
	E	A	Bi	n	F			
3/4	2 3/8	1.311	1.634	.669	3/8	HC 204-12	FL204	1.54
7/8 1 5/16 1	2 11/16	1.406	1.689	.685	3/8	HC 205-14 HC 205-15 HC 205-16	FL205	1.76
1 1/8 1 3/16 1 1/4	3 5/32	1.583	1.894	.716	3/8	HC 206-18 HC 206-19 HC 206-20	FL206	2.64
1 1/4 1 5/16 1 3/8 1 7/16	3 17/32	1.748	2.020	.740	1/2	HC 207-20 HC 207-21 HC 207-22 HC 207-23	FL207	3.53
1 1/2 1 9/16	3 15/16	2.016	2.201	.842	1/2	HC 208-24 HC 208-25	FL208	4.19
1 5/8 1 11/16 1 3/4	4 1/4	2.055	2.240	.842	5/8	HC 209-26 HC 209-27 HC 209-28	FL209	5.07



BALL BEARINGS

For personal service 800.242.4633
CAD drawings at no additional charge
For nomenclature see pages 240 and 241

MOLINE BEARING CO.



NORMAL DUTY HC 2-BOLT FLANGE CONTINUED

HCFL 200 Series—Mounted Ball Bearing Eccentric Set Screw Locking Collar

SHAFT SIZE	MOLINE PART #	UNIT #	DYNAMIC CAPACITY LBS	DIMENSIONS (INCHES)				
				B	D	J	H	C
1 7/8	19501114	HCFL 210-30	7891	7 3/4	6 3/16	.866	.630	1 27/32
1 15/16	19501115	HCFL 210-31						
2	19501200-10	HCFL 210-32						
2	19501200	HCFL 211-32	9790	8 13/16	7 1/4	.984	.709	1 31/32
2 1/8	19501202	HCFL 211-34						
2 3/16	19501203	HCFL 211-35						
2 1/4	19501204	HCFL 212-36	10746	9 27/32	7 15/16	1.142	.709	1 5/32
2 3/8	19501206	HCFL 212-38						
2 7/16	19501207	HCFL 212-39						
2 1/2	19501208	HCFL 213-40	12859	10 5/32	8 17/64	1.181	.787	2 11/16
2 3/4	19501212	HCFL 214-44	13668	10 7/16	8 1/2	1.22	.787	2 11/16
2 15/16	19501215	HCFL 215-47	14837	10 53/64	8 55/64	1.339	.866	2 15/16
3	19501300	HCFL 215-48						

For sale as complete units, inserts and housings.

BALL BEARINGS

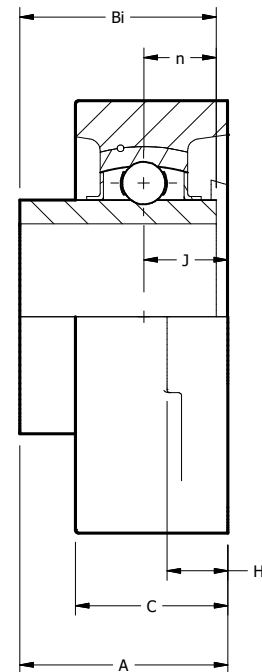
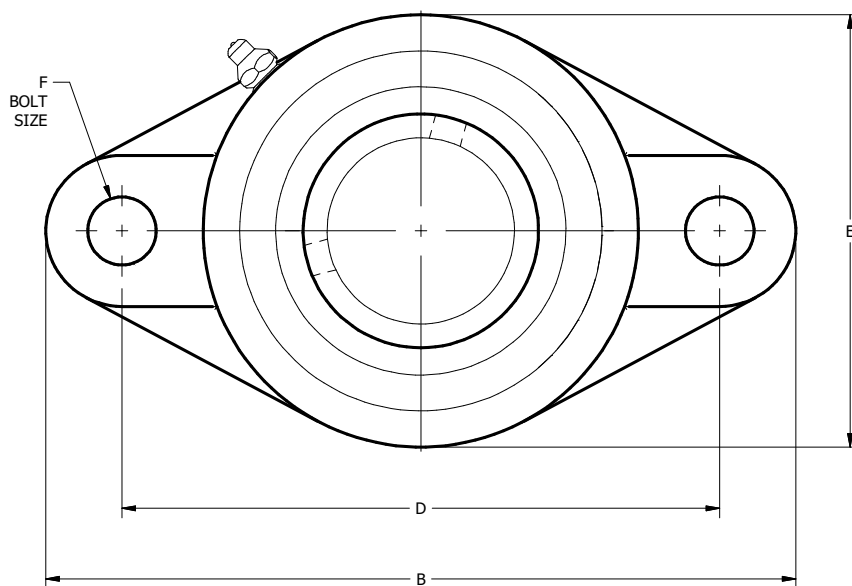

NORMAL DUTY HC 2-BOLT FLANGE

SHAFT SIZE	DIMENSIONS (INCHES)					INSERT #	HOUSING #	WEIGHT LBS.
	E	A	Bi	n	F			
1 7/8 1 15/16 2	4 1/2	2.150	2.366	.969	5/8	HC 210-30 HC 210-31 HC 210-32	FL210	5.73
2 2 1/8 2 3/16	5 1/8	2.299	2.701	1.091	5/8	HC 211-32 HC 211-34 HC 211-35	FL211	8.38
2 1/4 2 3/8 2 7/16	5 1/2	2.705	2.984	1.216	5/8	HC 212-36 HC 212-38 HC 212-39	FL212	10.58
2 1/2	6 1/8	2.744	3.213	1.342	3/4	HC 213-40	FL213	13.23
2 3/4	6 5/16	2.969	3.252	1.342	3/4	HC 214-44	FL214	13.89
2 15/16 3	6 1/2	3.091	3.496	1.468	3/4	HC 215-47 HC 215-48	FL215	15.87



BALL BEARINGS

For personal service 800.242.4633
CAD drawings at no additional charge
For nomenclature see pages 240 and 241

MOLINE BEARING CO.



NORMAL DUTY HC 4-BOLT FLANGE

HCF 200 Series—Mounted Ball Bearing Eccentric Set Screw Locking Collar

SHAFT SIZE	MOLINE PART #	UNIT #	DYNAMIC CAPACITY LBS	DIMENSIONS (INCHES)				
				B	D	J	H	C
3/4	19511012	HCF 204-12	2878	3 5/8	2 1/2	.591	1 5/32	1 5/32
7/8	19511014	HCF 205-14	3147	3 3/4	2 3/4	.630	9/16	1 7/32
1 5/16	19511015	HCF 205-15						
1	19511100	HCF 205-16						
1 1/8	19511102	HCF 206-18	4384	4 1/4	3 1/4	.709	9/16	1 31/32
1 3/16	19511103	HCF 206-19						
1 1/4	19511104-06	HCF 206-20						
1 1/4	19511104	HCF 207-20	5778	4 5/8	3 5/8	.748	5/8	1 7/16
1 5/16	19511105	HCF 207-21						
1 3/8	19511106	HCF 207-22						
1 7/16	19511107	HCF 207-23						
1 1/2	19511108	HCF 208-24	6654	5 1/8	4	.827	5/8	1 17/32
1 9/16	19511109	HCF 208-25						
1 5/8	19511110	HCF 209-26	7160	5 3/8	4 1/8	.866	23/32	1 9/16
1 11/16	19511111	HCF 209-27						
1 3/4	19511112	HCF 209-28						

For sale as complete units, inserts and housings.

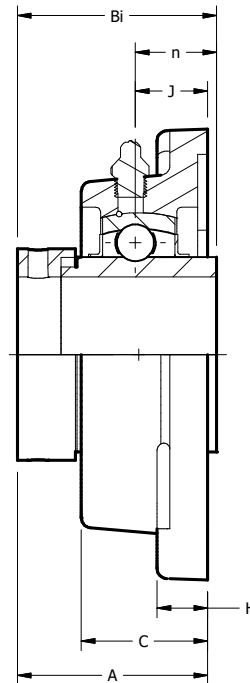
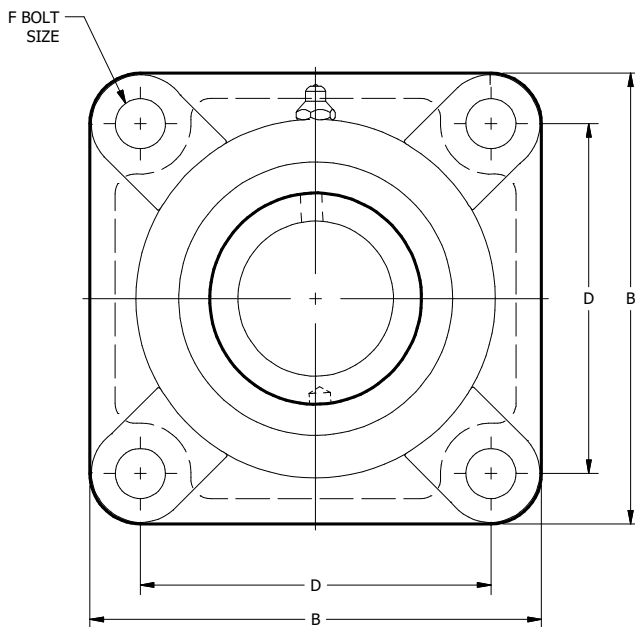

BALL BEARINGS



NORMAL DUTY HC 4-BOLT FLANGE

SHAFT SIZE	DIMENSIONS (INCHES)				INSERT #	HOUSING #	WEIGHT LBS.
	A	Bi	n	F			
3/4	1.311	1.634	.669	3/8	HC 204-12	F204	1.39
7/8 15/16 1	1.406	1.689	.685	3/8	HC 205-14 HC 205-15 HC 205-16	F205	1.76
1 1/8 1 3/16 1 1/4	1.583	1.894	.716	3/8	HC 206-18 HC 206-19 HC 206-20	F206	2.64
1 1/4 1 5/16 1 3/8 1 7/16	1.748	2.020	.740	1/2	HC 207-20 HC 207-21 HC 207-22 HC 207-23	F207	3.53
1 1/2 1 9/16	2.016	2.201	.842	1/2	HC 208-24 HC 208-25	F208	4.19
1 5/8 1 11/16 1 3/4	2.055	2.240	.842	1/2	HC 209-26 HC 209-27 HC 209-28	F209	5.07



BALL BEARINGS

For personal service 800.242.4633
CAD drawings at no additional charge
For nomenclature see pages 240 and 241

MOLINE BEARING CO.



NORMAL DUTY HC 4-BOLT FLANGE CONTINUED

HCF 200 Series—Mounted Ball Bearing Eccentric Set Screw Locking Collar

SHAFT SIZE	MOLINE PART #	UNIT #	DYNAMIC CAPACITY LBS	DIMENSIONS (INCHES)				
				B	D	J	H	C
1 7/8	19511114	HCF 210-30	7891	5 5/8	4 3/8	.866	5/8	1 27/32
1 15/16	19511115	HCF 210-31						
2	19511200-10	HCF 210-32						
2	19511200	HCF 211-32	9790	6 3/8	5 1/8	.984	23/32	1 31/32
2 1/8	19511202	HCF 211-34						
2 3/16	19511203	HCF 211-35						
2 1/4	19511204	HCF 212-36	10746	6 7/8	5 5/8	1.142	23/32	2 5/32
2 3/8	19511206	HCF 212-38						
2 7/16	19511207	HCF 212-39						
2 1/2	19511208	HCF 213-40	12859	7 3/8	5 7/8	1.181	7/8	2 5/16
2 3/4	19511212	HCF 214-44	13668	7 1/2	6	1.220	29/32	2 3/8
2 15/16	19511215	HCF 215-47	14837	7 7/8	6 1/4	1.339	7/8	2 27/64
3	19511300	HCF 215-48						

For sale as complete units, inserts and housings.

BALL BEARINGS

F BOLT SIZE

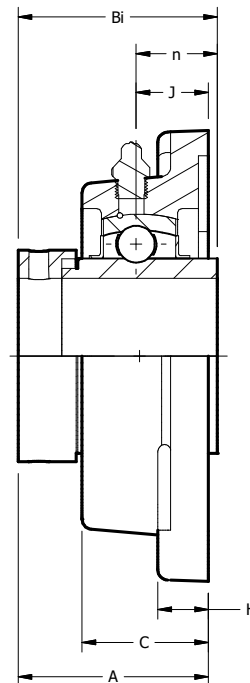
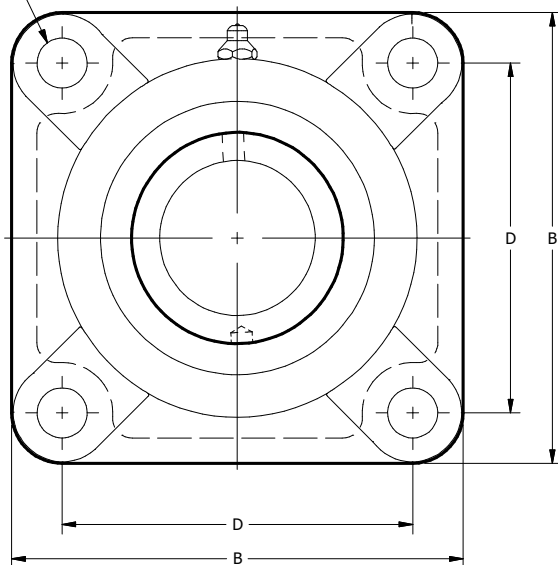

NORMAL DUTY HC 4-BOLT FLANGE

SHAFT SIZE	DIMENSIONS (INCHES)				INSERT #	HOUSING #	WEIGHT LBS.
	A	Bi	n	F			
1 7/8 1 15/16 2	2.150	2.366	.969	1/2	HC 210-30 HC 210-31 HC 210-32	F210	5.73
2 2 1/8 2 3/16	2.299	2.701	1.091	5/8	HC 211-32 HC 211-34 HC 211-35	F211	8.38
2 1/4 2 3/8 2 7/16	2.705	2.984	1.216	5/8	HC 212-36 HC 212-38 HC 212-39	F212	10.58
2 1/2	2.744	3.213	1.342	5/8	HC 213-40	F213	13.23
2 3/4	2.969	3.252	1.342	5/8	HC 214-44	F214	13.89
2 15/16 3	3.091	3.496	1.468	5/8	HC 215-47 HC 215-48	F215	15.87



BALL BEARINGS

For personal service 800.242.4633
CAD drawings at no additional charge
For nomenclature see pages 240 and 241

MOLINE BEARING CO.



NORMAL DUTY HC PILOTED FLANGE

HCFC 200 Series—Mounted Ball Bearing Eccentric Set Screw Locking Collar

SHAFT SIZE	MOLINE PART #	UNIT #	DYNAMIC CAPACITY LBS	DIMENSIONS (INCHES)						
				B	D	M	E	C	J	H
3/4	19531012	HCFC 204-12	2878	3 15/16	3 35/64	2.169	.394	1	.197	.236
7/8	19531014	HCFC 205-14	3147	4 1/2	3 35/64	2.504	.394	1.063	.236	.275
15/16	19531015	HCFC 205-15								
1	19531100	HCFC 205-16								
1 1/8	19531102	HCFC 206-18	4384	4 15/16	3 15/16	2.783	.394	1.220	.315	.315
1 3/16	19531103	HCFC 206-19								
1 1/4	19531104-06	HCFC 206-20								
1 1/4	19531104	HCFC 207-20	5778	5 5/16	4 22/64	3.063	.433	1.338	.315	.354
1 5/16	19531105	HCFC 207-21								
1 3/8	19531106	HCFC 207-22								
1 7/16	19531107	HCFC 207-23								
1 1/2	19531108	HCFC 208-24	6654	5 11/16	4 23/32	3.338	.433	1.417	.394	.354
1 9/16	19531109	HCFC 208-25								
1 5/8	19531110	HCFC 209-26	7160	6 3/8	5 13/64	3.673	.394	1.496	.472	.294
1 11/16	19531111	HCFC 209-27								
1 3/4	19531112	HCFC 209-28								

For sale as complete units, inserts and housings.

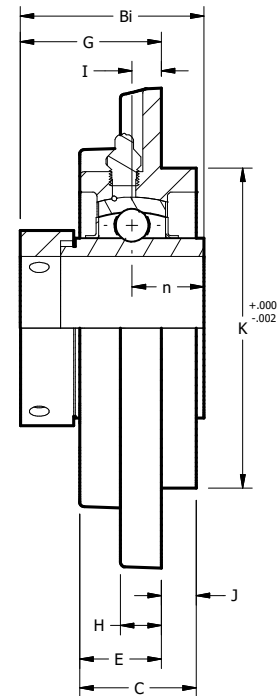
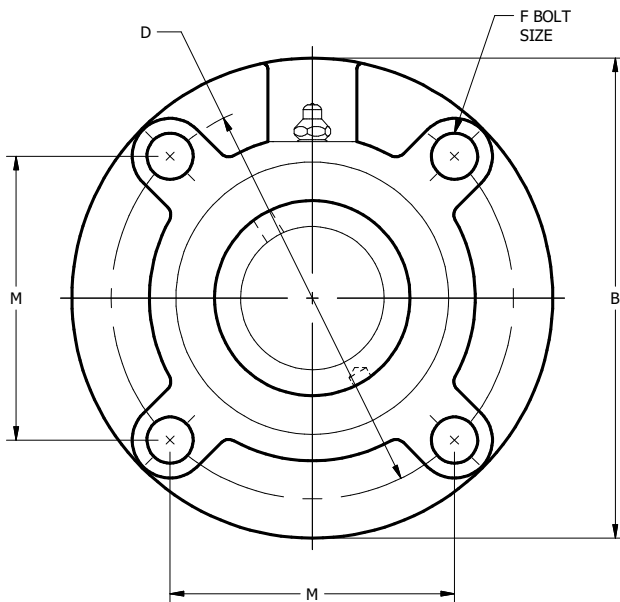

BALL BEARINGS



NORMAL DUTY HC PILOTED FLANGE

SHAFT SIZE	DIMENSIONS (INCHES)						INSERT #	HOUSING #	WEIGHT LBS.
	I	K	G	Bi	n	F			
3/4	.807	2.4409	1.437	1.712	.6693	3/8	HC 204-12	FC204	1.68
7/8 15/16 1	.827	2.7559	1.453	1.744	.6850	3/8	HC 205-14 HC 205-15 HC 205-16	FC205	2.12
1 1/8 1 3/16 1 1/4	.905	3.1496	1.580	1.901	.7165	3/8	HC 206-18 HC 206-19 HC 206-20	FC206	3.02
1 1/4 1 5/16 1 3/8 1 7/16	1.023	3.5433	1.705	2.012	.7402	7/16	HC 207-20 HC 207-21 HC 207-22 HC 207-23	FC207	3.75
1 1/2 1 9/16	1.023	3.9370	1.807	2.216	.8425	7/16	HC 208-24 HC 208-25	FC208	4.41
1 5/8 1 11/16 1 3/4	1.023	4.1339	1.768	2.216	.8425	1/2	HC 209-26 HC 209-27 HC 209-28	FC209	5.95



BALL BEARINGS

For personal service 800.242.4633
 CAD drawings at no additional charge
 For nomenclature see pages 240 and 241

MOLINE BEARING CO.



NORMAL DUTY HC PILOTED FLANGE CONTINUED

HCFC 200 Series—Mounted Ball Bearing Eccentric Set Screw Locking Collar

SHAFT SIZE	MOLINE PART #	UNIT #	DYNAMIC CAPACITY LBS	DIMENSIONS (INCHES)						
				B	D	M	E	C	J	H
1 7/8	19531114	HCFC 210-30	7891	6 1/2	5 7/16	3.842	.394	1.575	.472	.551
1 15/16	19531115	HCFC 210-31								
2	19531200-10	HCFC 210-32								
2	19531200	HCFC 211-32	9790	7 5/16	5 29/32	4.177	.512	1.653	.472	.512
2 1/8	19531202	HCFC 211-34								
2 3/16	19531203	HCFC 211-35								
2 1/4	19531204	HCFC 212-36	10746	7 11/16	6 19/64	4.453	.669	1.890	.472	.591
2 3/8	19531206	HCFC 212-38								
2 7/16	19531207	HCFC 212-39								
2 1/2	19531208	HCFC 213-40	12859	8 1/16	6 11/16	4.732	.630	1.929	.551	.591
2 3/4	19531212	HCFC 214-44	13668	8 15/32	6 31/32	4.925	.669	2.126	.551	.630
2 15/16	19531215	HCFC 215-47	14837	8 21/32	7 1/4	5.122	.669	2.165	.630	.669
3	19531300	HCFC 215-48								

For sale as complete units, inserts and housings.

BALL BEARINGS

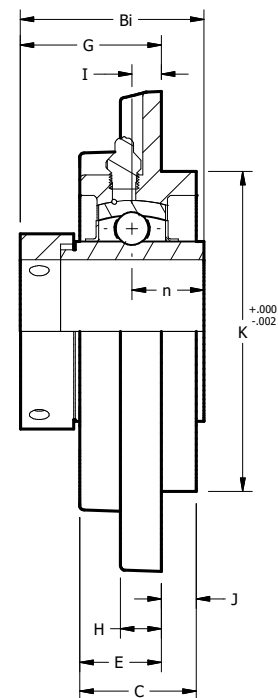
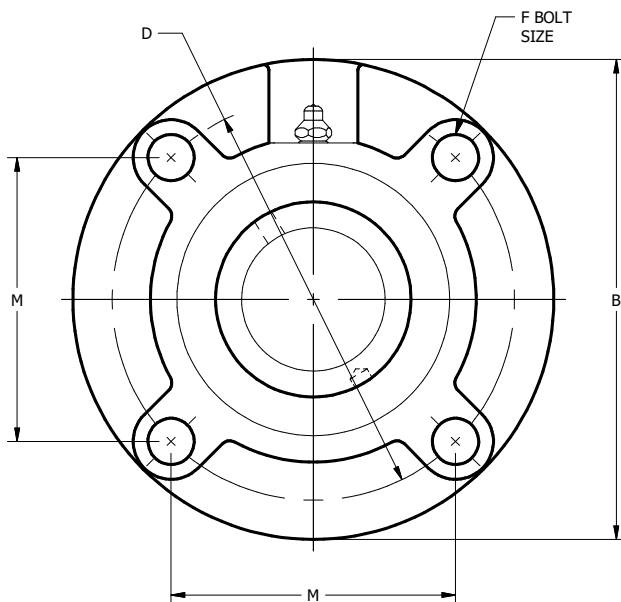

NORMAL DUTY HC PILOTED FLANGE

SHAFT SIZE	DIMENSIONS (INCHES)						INSERT #	HOUSING #	WEIGHT LBS.
	I	K	G	Bi	n	F			
1 7/8 1 15/16 2	1.102	4.3307	1.894	2.468	.9685	1/2	HC 210-30 HC 210-31 HC 210-32	FC210	6.39
2 2 1/8 2 3/16	1.181	4.9213	2.228	2.811	1.0906	5/8	HC 211-32 HC 211-34 HC 211-35	FC211	9.26
2 1/4 2 3/8 2 7/16	1.417	5.315	2.512	3.063	1.2165	5/8	HC 212-36 HC 212-38 HC 212-39	FC212	10.89
2 1/2	1.378	5.709	2.661	3.374	1.3425	5/8	HC 213-40	FC213	12.57
2 3/4	1.496	5.905	2.701	3.374	1.342	5/8	HC 214-44	FC214	14.99
2 15/16 3	1.535	6.2992	2.866	3.626	1.4685	5/8	HC 215-47 HC 215-48	FC215	29.76



BALL BEARINGS

For personal service 800.242.4633
CAD drawings at no additional charge
For nomenclature see pages 240 and 241

MOLINE BEARING CO.



NORMAL DUTY HC WIDE SLOT TAKE-UP

HCT 200 Series—Mounted Ball Bearing Eccentric Set Screw Locking Collar

SHAFT SIZE	MOLINE PART #	UNIT #	DYNAMIC CAPACITY LBS	DIMENSIONS (INCHES)						
				H	G	J	K	F	D	C
3/4	19551012	HCT 204-12	2878	5/8	3/8	2	1 1/4	3/4	2	15/32
7/8	19551014	HCT 205-14	3147	5/8	3/8	2	1 1/4	7/8	2	15/32
15/16	19551015	HCT 205-15								
1	19551100	HCT 205-16								
1 1/8	19551102	HCT 206-18	4384	5/8	3/8	2 3/16	1 7/16	7/8	2 1/4	15/32
1 3/16	19551103	HCT 206-19								
1 1/4	19551104-06	HCT 206-20								
1 1/4	19551104	HCT 207-20	5778	5/8	1/2	2 1/2	1 7/16	7/8	2 1/2	15/32
1 5/16	19551105	HCT 207-21								
1 3/8	19551106	HCT 207-22								
1 7/16	19551107	HCT 207-23								
1 1/2	19551108	HCT 208-24	6654	3/4	5/8	3 1/4	1 15/16	1 1/8	3 1/4	5/8
1 9/16	19551109	HCT 208-25								
1 5/8	19551110	HCT 209-26	7160	3/4	5/8	3 1/4	1 15/16	1 1/8	3 1/4	5/8
1 11/16	19551111	HCT 209-27								
1 3/4	19551112	HCT 209-28								

For sale as complete units, inserts and housings.

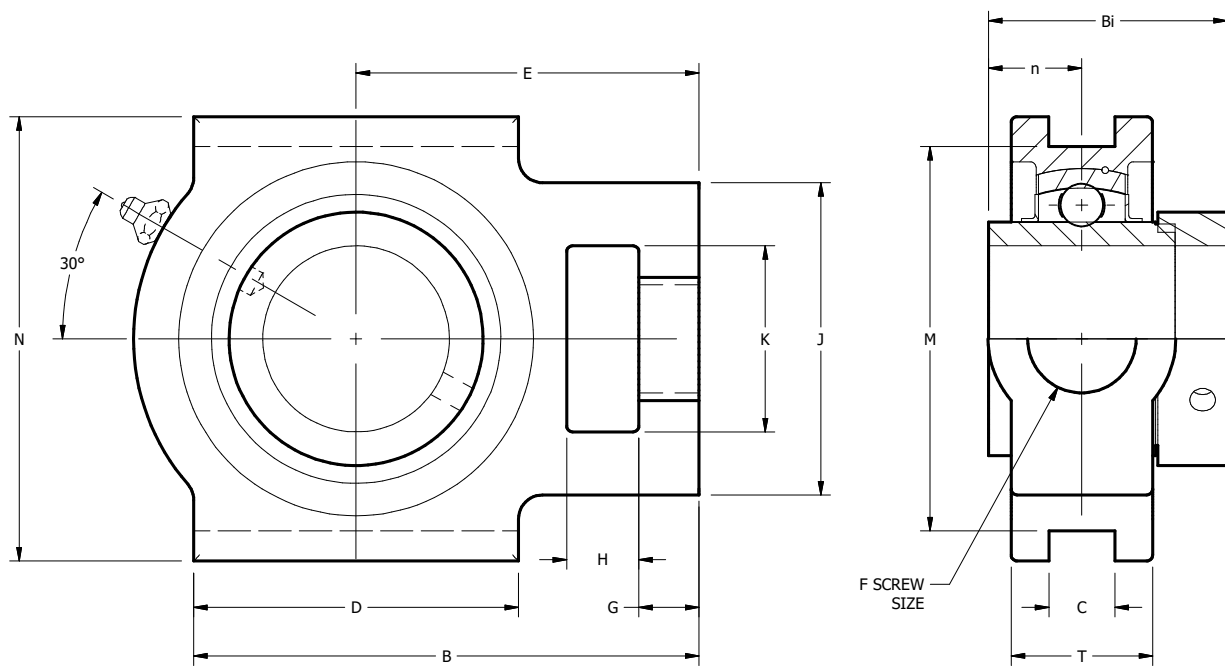

BALL BEARINGS



NORMAL DUTY HC WIDE SLOT TAKE-UP

SHAFT SIZE	DIMENSIONS (INCHES)							INSERT #	HOUSING #	WEIGHT LBS.
	M	N	B	T	E	Bi	n			
3/4	3	3 1/2	3 11/16	1 13/16	2 3/8	1.712	.669	HC 204-12	T204	1.85
7/8 15/16 1	3	3 1/2	3 13/16	1 5/16	2 7/16	1.744	.685	HC 205-14 HC 205-15 HC 205-16	T205	2.03
1 1/8 1 3/16 1 1/4	3 1/2	4	4 7/16	1 3/32	2 3/4	1.901	.716	HC 206-18 HC 206-19 HC 206-20	T206	3.06
1 1/4 1 5/16 1 3/8 1 7/16	3 1/2	4	5 1/16	1 3/16	3 1/16	2.012	.740	HC 207-20 HC 207-21 HC 207-22 HC 207-23	T207	4.03
1 1/2 1 9/16	4	4 1/2	5 11/16	1 5/16	3 1/2	2.216	.842	HC 208-24 HC 208-25	T208	5.82
1 5/8 1 11/16 1 3/4	4	4 5/8	5 11/16	1 3/8	3 7/16	2.216	.842	HC 209-26 HC 209-27 HC 209-28	T209	5.89

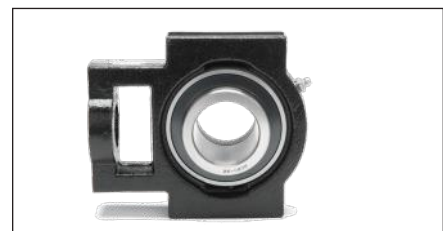

BALL BEARINGS

For personal service 800.242.4633
 CAD drawings at no additional charge
 For nomenclature see pages 240 and 241

MOLINE BEARING CO



NORMAL DUTY HC WIDE SLOT TAKE-UP CONTINUED

HCT 200 Series—Mounted Ball Bearing Eccentric Set Screw Locking Collar

SHAFT SIZE	MOLINE PART #	UNIT #	DYNAMIC CAPACITY LBS	DIMENSIONS (INCHES)						
				H	G	J	K	F	D	C
1 7/8	19551114	HCT 210-30	7891	3/4	5/8	3 1/4	1 15/16	1 1/8	3 3/8	1 1/16
1 15/16	19551115	HCT 210-31								
2	19551200-10	HCT 210-32								
2	19551200	HCT 211-32	9790	1	3/4	4	2 1/2	1 3/8	3 3/4	1 1/32
2 1/8	19551202	HCT 211-34								
2 3/16	19551203	HCT 211-35								
2 1/4	19551204	HCT 212-36	10746	1 1/4	3/4	4	2 1/2	1 3/8	4	1 1/32
2 3/8	19551206	HCT 212-38								
2 7/16	19551207	HCT 212-39								
2 1/2	19551208	HCT 213-40	12859	1 1/4	13/16	4 3/8	2 3/4	1 1/2	4 3/4	1 1/32
2 3/4	19551212	HCT 214-44	13668	1 5/16	13/16	4 3/8	2 3/4	1 1/2	4 3/4	1 1/32
2 15/16	19551215	HCT 215-47	14837	1 1/4	13/16	4 3/8	2 3/4	1 1/2	4 3/4	1 1/32
3	19551300	HCT 215-48								

For sale as complete units, inserts and housings.

BALL BEARINGS

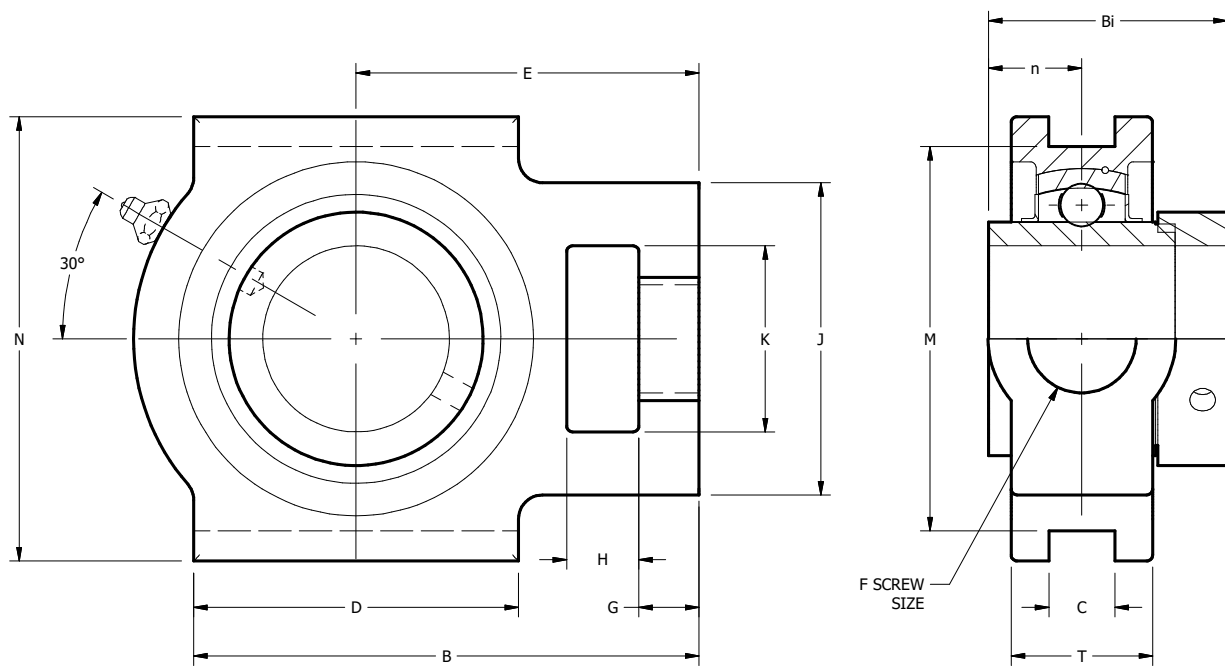

NORMAL DUTY HC WIDE SLOT TAKE-UP

SHAFT SIZE	DIMENSIONS (INCHES)							INSERT #	HOUSING #	WEIGHT LBS.
	M	N	B	T	E	Bi	n			
1 7/8 1 15/16 2	4	4 5/8	5 7/8	1 15/32	3 9/16	2.468	.968	HC 210-30 HC 210-31 HC 210-32	T210	6.19
2 2 1/8 2 3/16	5 1/8	5 3/4	6 3/4	1 1/2	4 3/16	2.807	1.090	HC 211-32 HC 211-34 HC 211-35	T211	9.41
2 1/4 2 3/8 2 7/16	5 1/8	5 3/4	7 5/8	1 21/32	4 11/16	3.059	1.216	HC 212-36 HC 212-38 HC 212-39	T212	11.60
2 1/2	5 15/16	6 9/16	8 13/16	1 3/4	5 3/8	3.374	1.342	HC 213-40	T213	16.64
2 3/4	5 15/16	6 9/16	8 13/16	1 13/16	5 3/8	3.374	1.342	HC 214-44	T214	16.80
2 15/16 3	5 15/16	6 9/16	9 1/8	1 7/8	5 1/2	3.626	1.468	HC 215-47 HC 215-48	T215	17.92

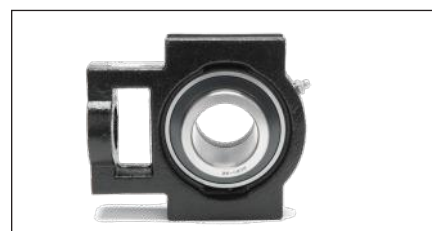

BALL BEARINGS

For personal service 800.242.4633
CAD drawings at no additional charge
For nomenclature see pages 240 and 241

MOLINE BEARING CO



NORMAL DUTY HC 200 SERIES INSERT

Mounted Ball Bearing Eccentric Set Screw Locking Collar

SHAFT SIZE	MOLINE #	UNIT #	DIMENSIONS (INCHES)										WEIGHT LBS.
			D	Bi	Be	n	m	i	L	H	G	ds	
3/4	15500012	HC 204-12	1.8504	1.712	.669	.669	.669	.374	1.311	.531	.189	1/4-28	.45
7/8	15500014	HC 205-14	2.0472	1.744	.669	.685	.685	.374	1.500	.531	.189	1/4-28	.60
15/16	15500015	HC 205-15											.60
1	15500100	HC 205-16											.55
1 1/8	15500102	HC 206-18	2.4409	1.901	.748	.716	.716	.468	1.752	.626	.236	5/16-24	.90
1 3/16	15500103	HC 206-19											.85
1 1/4	15500104-06	HC 206-20											.80
1 1/4	15500104	HC 207-20	2.8346	2.011	.787	.740	.740	.531	2.189	.689	.267	5/16-24	1.45
1 5/16	15500105	HC 207-21											1.40
1 3/8	15500106	HC 207-22											1.30
1 7/16	15500107	HC 207-23											1.25
1 1/2	15500108	HC 208-24	3.1496	2.216	.826	.842	.842	.531	2.374	.720	.267	5/16-24	1.80
1 9/16	15500109	HC 208-25											1.65
1 5/8	15500110	HC 209-26	3.3465	2.216	.866	.842	.842	.531	2.752	.720	.255	5/16-24	2.00
1 11/16	15500111	HC 209-27											1.90
1 3/4	15500112	HC 209-28											1.80
1 7/8	15500114	HC 210-30	3.5433	2.468	.905	.968	.968	.531	2.752	.720	.255	5/16-24	2.30
1 15/16	15500115	HC 210-31											2.20
2	15500200-10	HC 210-32											2.05
2	15500200	HC 211-32	3.9370	2.811	.944	1.090	1.090	.629	3.000	.818	.315	3/8-24	3.40
2 1/8	15500202	HC 211-34											3.05
2 3/16	15500203	HC 211-35											2.85
2 1/4	15500204	HC 212-36	4.3307	3.063	1.023	1.216	1.216	.629	3.315	.874	.323	3/8-24	4.20
2 3/8	15500206	HC 212-38											3.85
2 7/16	15500207	HC 212-39											3.60
2 1/2	15500208	HC 213-40	4.7244	3.374	1.063	1.342	1.342	.689	3.385	.925	.315	3/8-24	4.95
2 3/4	15500212	HC 214-44	4.9210	3.374	1.181	1.342	1.468	.689	3.811	.925	.354	3/8-24	5.35
2 15/16	15500215	HC 215-47	5.1181	3.626	1.181	1.468	1.468	.689	4.015	.925	.354	3/8-24	6.30
3	15500300	HC 215-48											5.75

BALL BEARINGS



NORMAL DUTY HC 200 SERIES INSERT

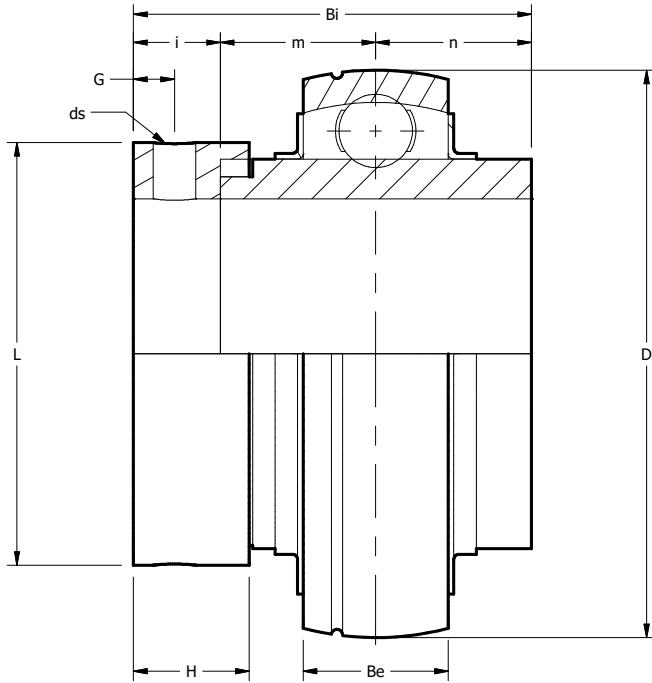

BALL BEARINGS

For personal service 800.242.4633
 CAD drawings at no additional charge
 For nomenclature see pages 240 and 241

MOLINE BEARING CO



MEDIUM DUTY UCX 2-BOLT PILLOW BLOCK

UCPX Series— Mounted Ball Bearing Set Screw Lock

SHAFT SIZE	MOLINE PART #	UNIT #	DYNAMIC CAPACITY LBS	DIMENSIONS (INCHES)				
				B	C	D	G	H
1	29421100	UCPX05-16	4384	6 ¼	2	4 11/16	13/16	13/16
1 1/8	29421102	UCPX06-18	5778	6 7/8	2 1/8	4 3/4	13/16	13/16
1 3/16	29421103	UCPX06-19						
1 1/4	29421104	UCPX06-20						
1 3/8	29421106	UCPX07-22	6654	8	2 1/4	5 5/8	13/16	13/16
1 7/16	29421107	UCPX07-23						
1 1/2	29421108	UCPX08-24	7160	8 3/4	6 9/16	6 1/8	15/16	15/16
1 5/8	29421110	UCPX09-26	7891	8 3/4	2 5/8	6 1/8	15/16	1
1 11/16	29421111	UCPX09-27						
1 3/4	29421112	UCPX09-28						
1 7/8	29421114	UCPX10-30	9790	9 7/16	2 13/16	6 3/4	15/16	15/16
1 15/16	29421115	UCPX10-31						
2	29421200	UCPX10-32						

For sale as complete units, inserts and housings.

BALL BEARINGS

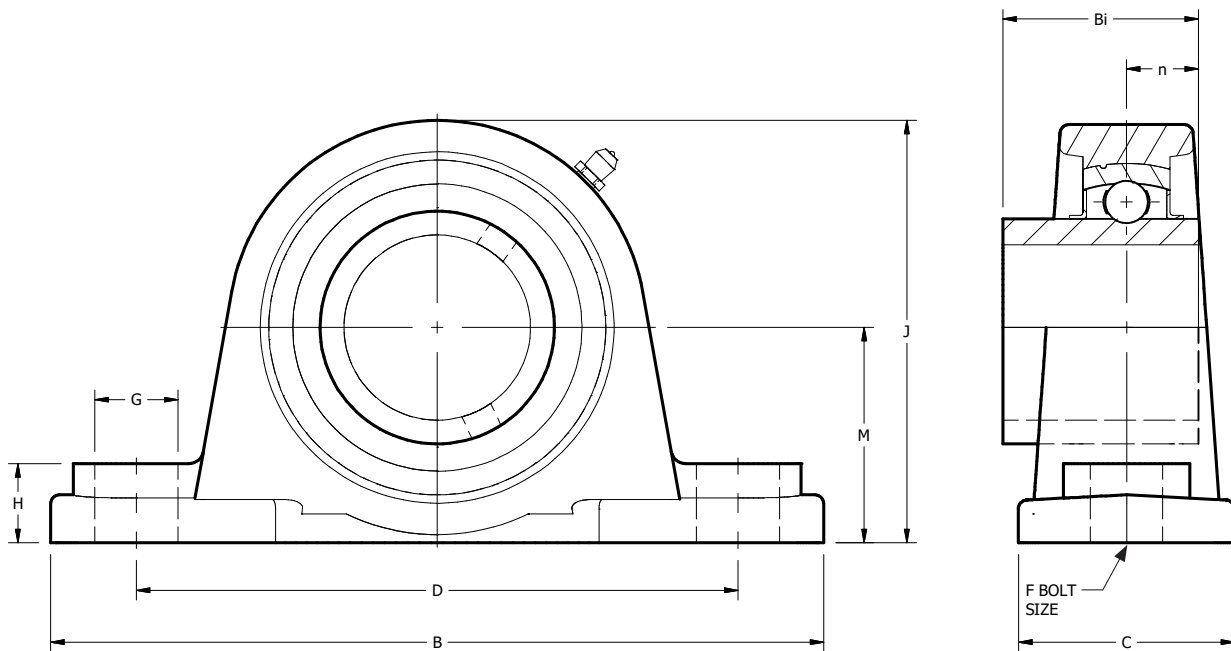

MEDIUM DUTY UCX 2-BOLT PILLOW BLOCK

SHAFT SIZE	DIMENSIONS (INCHES)					INSERT #	HOUSING #	WEIGHT LBS.
	J	M	Bi	n	F			
1	3 3/8	1 3/4	1.50	0.63	9/16	UCX05-16	PX05	3.31
1 1/8 1 3/16 1 1/4	3 5/8	1 7/8	1.69	0.69	9/16	UCX06-18 UCX06-19 UCX06-20	PX06	4.63
1 3/8 1 7/16	4 1/8	2 1/8	1.94	0.75	9/16	UCX07-22 UCX07-23	PX07	5.95
1 1/2	4 7/16	2 5/16	1.94	0.74	5/8	UCX08-24	PX08	7.72
1 5/8 1 11/16 1 3/4	4 9/16	2 5/16	2	0.75	5/8	UCX09-26 UCX09-27 UCX09-28	PX09	8.16
1 7/8 1 15/16 2	4 15/16	2 1/2	2.19	.88	5/8	UCX10-30 UCX10-31 UCX10-32	PX10	10.14



BALL BEARINGS

For personal service 800.242.4633
CAD drawings at no additional charge
For nomenclature see pages 240 and 241

MOLINE BEARING CO



MEDIUM DUTY UCX 2-BOLT PILLOW BLOCK CONTINUED

UCPX Series— Mounted Ball Bearing Set Screw Lock

SHAFT SIZE	MOLINE PART #	UNIT #	DYNAMIC CAPACITY LBS	DIMENSIONS (INCHES)				
				B	C	D	G	H
2 1/8	29421202	UCPX11-34	10746	10 1/4	3 1/8	7 1/4	1 1/8	1 1/8
2 3/16	29421203	UCPX11-35						
2 1/4	29421204	UCPX11-36						
2 3/8	29421206	UCPX12-38	12859	11	3 3/16	8	1 1/8	1 1/4
2 7/16	29421207	UCPX12-39						
2 1/2	29421208	UCPX13-40	13668	11 1/4	3 1/4	8	1 1/8	1 5/16
2 11/16	29421211	UCPX14-43	14847	12 5/8	3 3/8	9	1 3/16	1 5/16
2 15/16	29421215	UCPX15-47	16074	13	3 5/8	9	1 3/16	1 3/8
3	29421300	UCPX15-48						
3 7/16	29421307	UCPX17-55	21559	14 15/16	4	11 1/8	1 3/16	1 9/16
3 1/2	29421308	UCPX18-56	24504	15	4 3/16	11 1/8	1 3/16	1 9/16
3 15/16	29421315	UCPX20-63	29900	17	4 3/4	13 1/4	1 7/16	1 3/4
4	29421400	UCPX20-64						

For sale as complete units, inserts and housings.

BALL BEARINGS

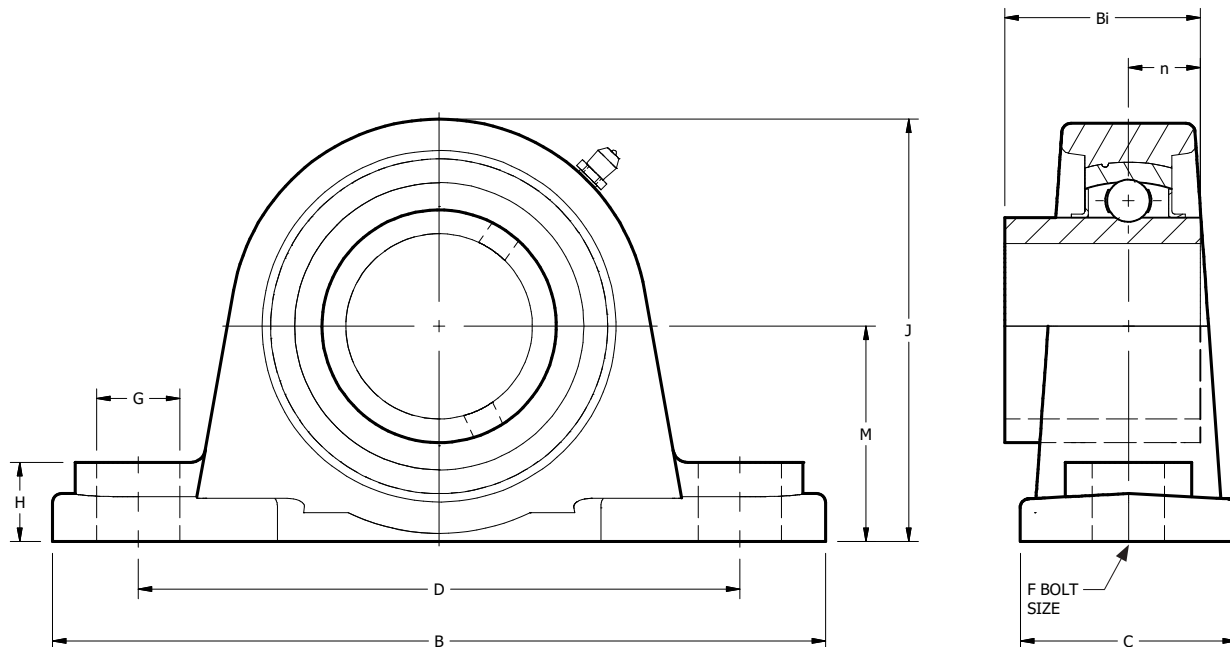

MEDIUM DUTY UCX 2-BOLT PILLOW BLOCK

SHAFT SIZE	DIMENSIONS (INCHES)					INSERT #	HOUSING #	WEIGHT LBS.
	J	M	Bi	n	F			
2 1/8 2 3/16 2 1/4	5 3/8	2 3/4	2.56	1	3/4	UCX11-34 UCX11-35 UCX11-36	PX11	14.33
2 3/8 2 7/16	5 7/8	3	2.56	1	3/4	UCX12-38 UCX12-39	PX12	16.98
2 1/2	6	3	2.94	1.19	3/4	UCX13-40	PX13	17.86
2 11/16	6 11/16	3 1/2	3.06	1.31	7/8	UCX14-43	PX14	22.49
2 15/16 3	6 7/8	3 1/2	3.25	1.31	7/8	UCX15-47 UCX15-48	PX15	23.81
3 7/16	7 7/8	4	3.75	1.56	7/8	UCX17-55	PX17	35.49
3 1/2	8 1/8	4	4.09	1.69	7/8	UCX18-56	PX18	42.11
3 15/16 4	9 5/8	5	4.63	1.94	1 1/8	UCX20-63 UCX20-64	PX20	67.02



BALL BEARINGS

For personal service 800.242.4633
 CAD drawings at no additional charge
 For nomenclature see pages 240 and 241

MOLINE BEARING CO



MEDIUM DUTY UCX 2-BOLT FLANGE

UCFLX Series— Mounted Ball Bearing Set Screw Lock

SHAFT SIZE	MOLINE PART #	UNIT #	DYNAMIC CAPACITY LBS	DIMENSIONS (INCHES)				
				A	B	C	D	E
1	29401100	UCFLX 05-16	4384	1.58	5 ⁹ / ₁₆	1 ³ / ₁₆	4 ⁵ / ₈	3 ¹ / ₄
1 ¹ / ₈	29401102	UCFLX 06-18	5778	1.75	6 ¹ / ₈	1 ⁹ / ₁₆	5 ¹ / ₈	3 ³ / ₄
1 ³ / ₁₆	29401103	UCFLX 06-19						
1 ¹ / ₄	29401104	UCFLX 06-20						
1 ³ / ₈	29401106	UCFLX 07-22	6654	2.02	6 ³ / ₄	1 ¹ / ₂	5 ¹¹ / ₁₆	4 ¹ / ₈
1 ⁷ / ₁₆	29401107	UCFLX 07-23						
1 ¹ / ₂	29401108	UCFLX 08-24	7160	2.06	7 ¹ / ₁₆	1 ⁹ / ₁₆	5 ¹³ / ₁₆	4 ³ / ₈
1 ⁵ / ₈	29401110	UCFLX 09-26	7891	2.19	7 ⁷ / ₁₆	1 ⁹ / ₁₆	6 ³ / ₁₆	4 ⁹ / ₁₆
1 ¹¹ / ₁₆	29401111	UCFLX 09-27						
1 ³ / ₄	29401112	UCFLX 09-28						
1 ⁷ / ₈	29401114	UCFLX 10-30	9790	2.34	8 ¹ / ₂	1 ³ / ₄	7 ¹ / ₄	5 ¹ / ₄
1 ¹⁵ / ₁₆	29401115	UCFLX 10-31						
2	29401200	UCFLX 10-32						

For sale as complete units, inserts and housings.

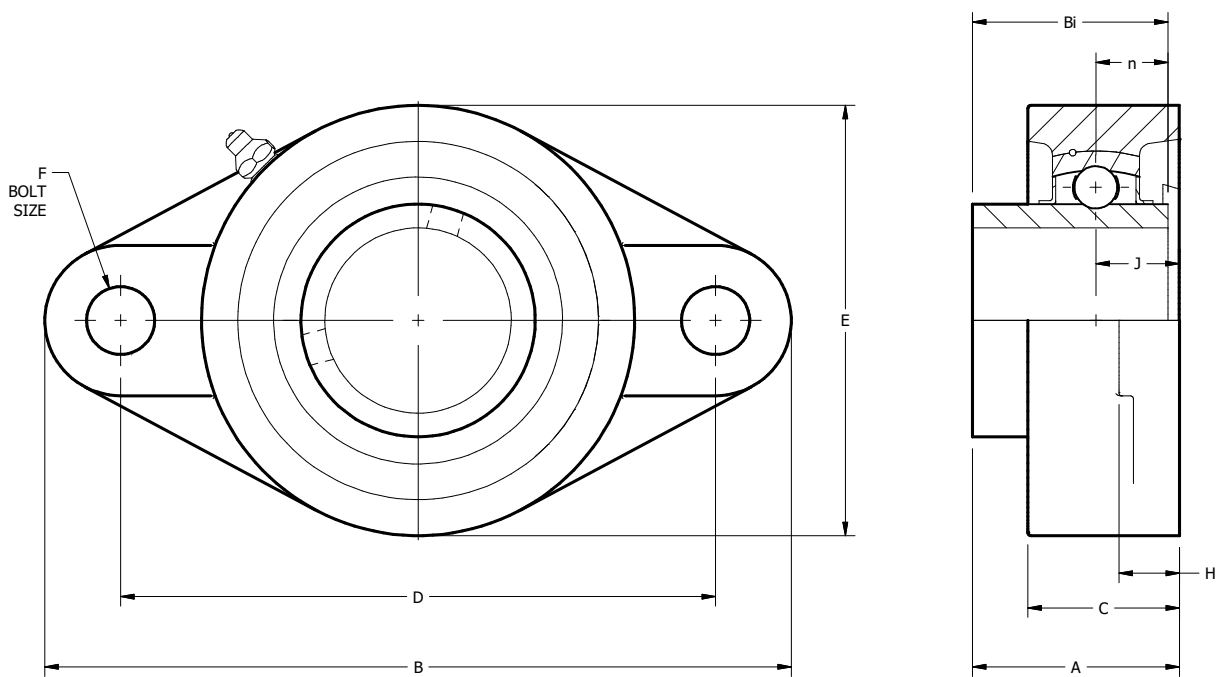

MEDIUM DUTY UCX 2-BOLT FLANGE

SHAFT SIZE	DIMENSIONS (INCHES)					INSERT #	HOUSING #	WEIGHT LBS.
	H	J	n	Bi	F			
1	1/2	.63	11/16	1.50	7/16	UCX05-16	FLX05	2.21
1 1/8 1 3/16 1 1/4	9/16	.69	3/4	1.69	9/16	UCX06-18 UCX06-19 UCX06-20	FLX06	3.31
1 3/8 1 7/16	9/16	.75	13/16	1.94	9/16	UCX07-22 UCX07-23	FLX07	4.41
1 1/2	9/16	.75	7/8	1.94	9/16	UCX08-24	FLX08	4.85
1 5/8 1 11/16 1 3/4	9/16	.75	15/16	2	9/16	UCX09-26 UCX09-27 UCX09-28	FLX09	5.29
1 7/8 1 15/16 2	13/16	.87	1	2.19	5/8	UCX10-30 UCX10-31 UCX10-32	FLX10	7.50



BALL BEARINGS

For personal service 800.242.4633
 CAD drawings at no additional charge
 For nomenclature see pages 240 and 241

MOLINE BEARING CO.



MEDIUM DUTY UCX 4-BOLT FLANGE

UCFX Series— Mounted Ball Bearing Set Screw Lock

SHAFT SIZE	MOLINE PART #	UNIT #	DYNAMIC CAPACITY LBS	DIMENSIONS (INCHES)			
				A	B	C	D
1	29411100	UCFX05-16	4384	1 ⁹ / ₁₆	4 ¹ / ₄	1 ³ / ₁₆	3 ¹ / ₄
1 ¹ / ₈	29411102	UCFX06-18	5778	1 ³ / ₄	4 ⁵ / ₈	1 ⁵ / ₁₆	3 ⁵ / ₈
1 ³ / ₁₆	29411103	UCFX06-19					
1 ¹ / ₄	29411104	UCFX06-20					
1 ³ / ₈	29411106	UCFX07-22	6654	2	5 ¹ / ₈	1 ¹ / ₂	4
1 ⁷ / ₁₆	29411107	UCFX07-23					
1 ¹ / ₂	29411108	UCFX08-24	7160	2 ¹ / ₁₆	5 ³ / ₈	1 ⁹ / ₁₆	4 ¹ / ₈
1 ⁵ / ₈	29411110	UCFX09-26	7891	2 ³ / ₁₆	5 ⁵ / ₈	1 ⁹ / ₁₆	4 ³ / ₈
1 ¹¹ / ₁₆	29411111	UCFX09-27					
1 ³ / ₄	29411112	UCFX09-28					
1 ⁷ / ₈	29411114	UCFX10-30	9790	2 ⁵ / ₁₆	6 ³ / ₈	1 ³ / ₄	5 ¹ / ₈
1 ¹⁵ / ₁₆	29411115	UCFX10-31					
2	29411200	UCFX10-32					

For sale as complete units, inserts and housings.

BALL BEARINGS

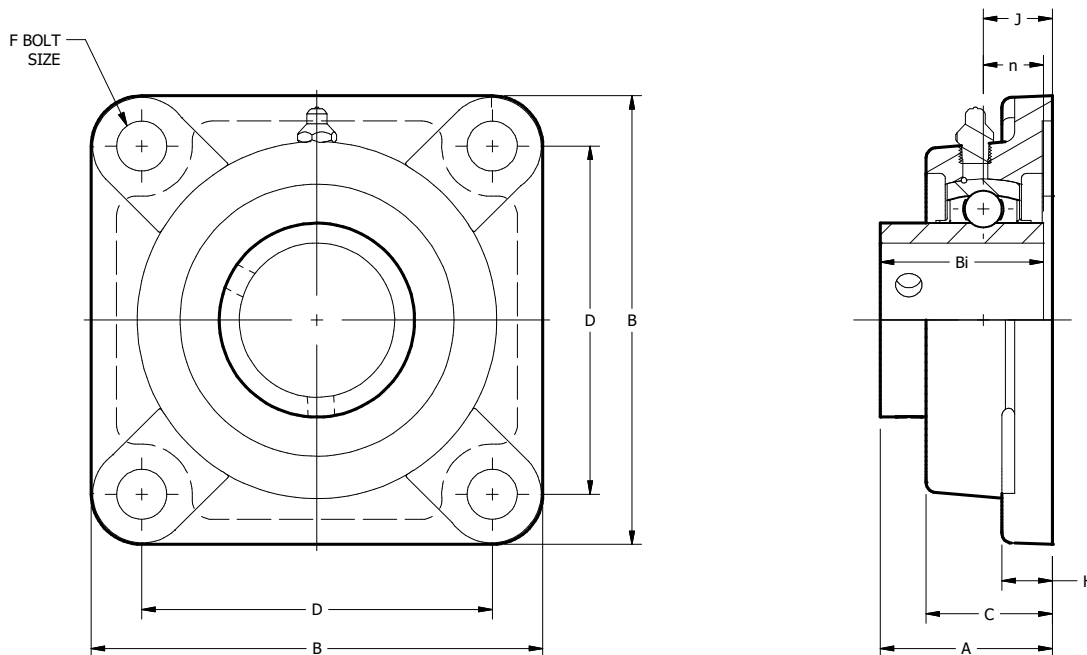

MEDIUM DUTY UCX 4-BOLT FLANGE

SHAFT SIZE	DIMENSIONS (INCHES)					INSERT #	HOUSING #	WEIGHT LBS.
	H	J	n	Bi	F			
1	1/2	5/8	11/16	1.50	7/16	UCX05-16	FX05	2.65
1 1/8 1 3/16 1 1/4	9/16	11/16	3/4	1.69	1/2	UCX06-18 UCX06-19 UCX06-20	FX06	3.53
1 3/8 1 7/16	9/16	3/4	13/16	1.94	1/2	UCX07-22 UCX07-23	FX07	4.41
1 1/2	9/16	3/4	7/8	1.94	9/16	UCX08-24	FX08	5.29
1 5/8 1 11/16 1 3/4	9/16	3/4	15/16	2	9/16	UCX09-26 UCX09-27 UCX09-28	FX09	5.95
1 7/8 1 15/16 2	13/16	7/8	1	2.19	5/8	UCX10-30 UCX10-31 UCX10-32	FX10	8.16



BALL BEARINGS

For personal service 800.242.4633
CAD drawings at no additional charge
For nomenclature see pages 240 and 241

MOLINE BEARING CO.



MEDIUM DUTY UCX 4-BOLT FLANGE CONTINUED

UCFX Series— Mounted Ball Bearing Set Screw Lock

SHAFT SIZE	MOLINE PART #	UNIT #	DYNAMIC CAPACITY LBS	DIMENSIONS (INCHES)			
				A	B	C	D
2 1/8	29411202	UCFX11-34	10746	2 11/16	6 7/8	1 15/16	5 5/8
2 3/16	29411203	UCFX11-35					
2 1/4	29411204	UCFX12-36					
2 3/8	29411206	UCFX12-38	12859	2 7/8	7 3/8	2 1/4	5 7/8
2 7/16	29411207	UCFX12-39					
2 1/2	29411208	UCFX13-40	13668	3 1/16	7 3/8	2 5/16	5 7/8
2 11/16	29411211	UCFX14-43	14837	3 3/16	7 3/4	2 3/8	6
2 15/16	29411215	UCFX15-47	16074	3 1/2	7 3/4	2 11/16	6
3	29411300	UCFX15-48					
3 1/16	29411307	UCFX17-55	21559	3 13/16	8 7/16	2 3/4	6 3/4
3 1/2	29411308	UCFX18-56	24504	4 3/16	8 7/16	3	6 3/4
3 15/16	29411315	UCFX20-63	29900	5	10 9/16	3 13/16	8 1/4
4	29411400	UCFX20-64					

For sale as complete units, inserts and housings.

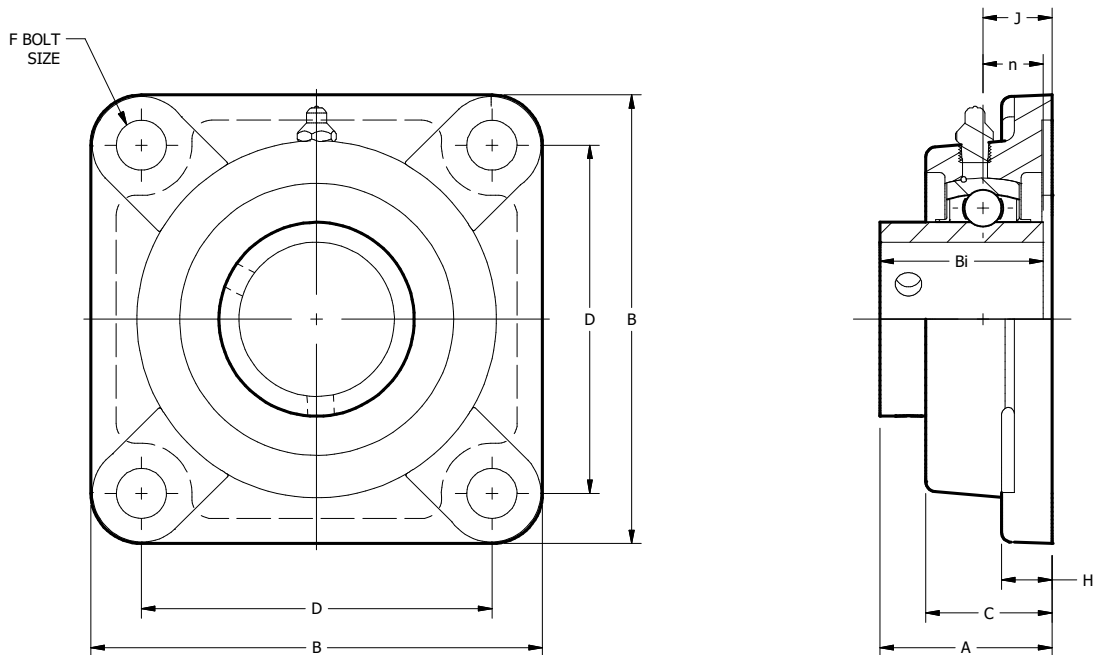

MEDIUM DUTY UCX 4-BOLT FLANGE

SHAFT SIZE	DIMENSIONS (INCHES)					INSERT #	HOUSING #	WEIGHT LBS.
	H	J	n	Bi	F			
2 1/8 2 3/16 2 1/4	13/16	1	1 1/8	2.56	5/8	UCX11-34 UCX11-35 UCX11-36	FX11	10.8
2 3/8 2 7/16	13/16	1	1 5/16	2.56	5/8	UCX12-38 UCX12-39	FX12	12.57
2 1/2	13/16	1 3/16	1 5/16	2.94	5/8	UCX13-40	FX13	13.89
2 11/16	15/16	1 5/16	1 7/16	3.06	3/4	UCX14-43	FX14	15.43
2 15/16 3	15/16	1 5/16	1 9/16	3.25	3/4	UCX15-47 UCX15-48	FX15	18.52
3 7/16	15/16	1 9/16	1 9/16	3.75	3/4	UCX17-55	FX17	23.81
3 1/2	15/16	1 3/4	1 3/4	4.09	3/4	UCX18-56	FX18	26.24
3 15/16 4	1 1/4	1 15/16	2 5/16	4.63	1 1/8	UCX20-63 UCX20-64	FX20	42.77



BALL BEARINGS

For personal service 800.242.4633
 CAD drawings at no additional charge
 For nomenclature see pages 240 and 241

MOLINE BEARING CO.



MEDIUM DUTY UCX PILOTED FLANGE

UCFCX Series— Mounted Ball Bearing Set Screw Lock

SHAFT SIZE	MOLINE PART #	UNIT #	DYNAMIC CAPACITY LBS	DIMENSIONS (INCHES)					
				B	C	D	E	G	H
1	29431100	UCFCX05-16	4384	4 ³ / ₈	1 ³ / ₁₆	3 ⁵ / ₈	1 ⁵ / ₁₆	1 ⁹ / ₃₂	3 ³ / ₈
1 ¹ / ₈	29451102	UCFCX06-18	5778	5	1 ¹ / ₄	4 ¹ / ₈	7 ⁷ / ₈	1 ⁵ / ₁₆	3 ³ / ₈
1 ³ / ₁₆	29431103	UCFCX06-19							
1 ¹ / ₄	29431104	UCFCX06-20							
1 ³ / ₈	29431106	UCFCX07-22	6654	5 ¹ / ₄	1 ⁷ / ₁₆	4 ³ / ₈	1	1 ¹⁷ / ₃₂	7 ⁷ / ₁₆
1 ⁷ / ₁₆	29431107	UCFCX07-23							
1 ¹ / ₂	29431108	UCFCX08-24	7160	5 ¹ / ₄	1 ⁷ / ₁₆	4 ³ / ₈	1	1 ¹⁷ / ₃₂	7 ⁷ / ₁₆
1 ⁵ / ₈	29431110	UCFCX09-26	7891	6 ¹ / ₈	1 ¹⁵ / ₁₆	5 ¹ / ₈	1	1 ¹⁹ / ₃₂	7 ⁷ / ₁₆
1 ¹ / ₁₆	29431111	UCFCX09-27							
1 ³ / ₄	29431112	UCFCX09-28							
1 ⁷ / ₈	29431114	UCFCX10-30	9790	6 ³ / ₈	1 ⁵ / ₈	5 ³ / ₈	1	1 ¹⁹ / ₃₂	7 ⁷ / ₁₆
1 ¹⁵ / ₁₆	29431115	UCFCX10-31							
2	29431200	UCFCX10-32							

For sale as complete units, inserts and housings.

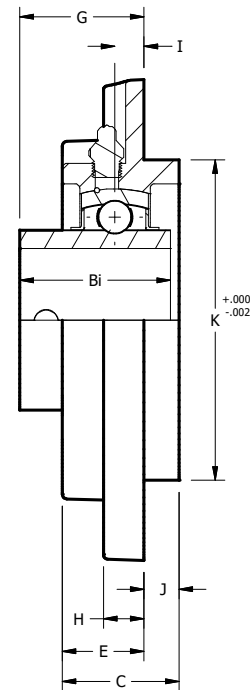
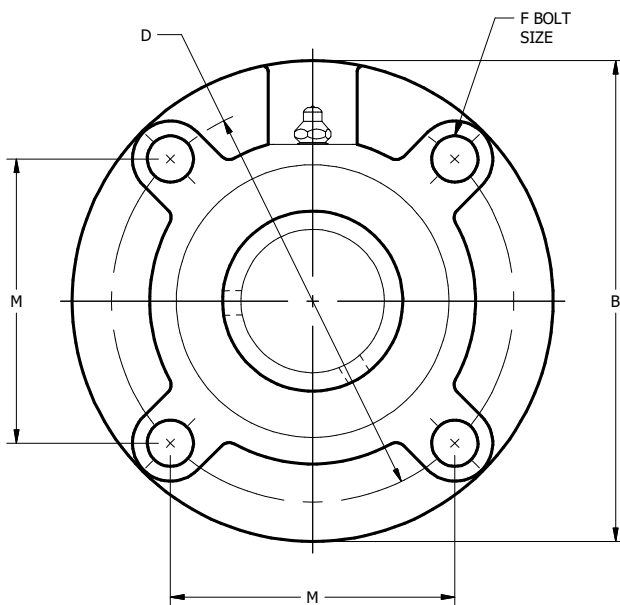

BALL BEARINGS



MEDIUM DUTY UCX PILOTED FLANGE

SHAFT SIZE	DIMENSIONS (INCHES)						INSERT #	HOUSING #	WEIGHT LBS.
	I	J	K	M	Bi	F			
1	13/32	1/4	3.000	2.56	1.50	5/16	UCX05-16	FCX05	2.45
1 1/8 1 3/16 1 1/4	5/16	3/8	3.375	2.94	1.69	3/8	UCX06-18 UCX06-19 UCX06-20	FCX06	3.30
1 3/8 1 7/16	3/8	7/16	3.625	3.09	1.94	3/8	UCX07-22 UCX07-23	FCX07	3.97
1 1/2	11/32	7/16	3.625	3.09	1.94	3/8	UCX08-24	FCX08	4.85
1 5/8 1 11/16 1 3/4	5/16	15/32	4.250	3.63	2.03	7/16	UCX09-26 UCX09-27 UCX09-28	FCX09	6.17
1 7/8 1 15/16 2	9/32	5/8	4.500	3.78	2.19	7/16	UCX10-30 UCX10-31 UCX10-32	FCX10	7.17



BALL BEARINGS

For personal service 800.242.4633
CAD drawings at no additional charge
For nomenclature see pages 240 and 241

MOLINE BEARING CO.



MEDIUM DUTY UCX PILOTED FLANGE CONTINUED

UCFCX Series— Mounted Ball Bearing Set Screw Lock

SHAFT SIZE	MOLINE PART #	UNIT #	DYNAMIC CAPACITY LBS	DIMENSIONS (INCHES)					
				B	C	D	E	G	H
2 1/8	29431208	UCFCX11-34	10746	7 1/8	1 7/8	6	1	1 23/32	1/2
2 3/16	29431203	UCFCX11-35							
2 1/4	29431204	UCFCX11-36							
2 3/8	29431206	UCFCX12-38	12859	7 5/8	2 3/32	6 1/2	1 5/16	2	9/16
2 7/16	29431207	UCFCX12-39							
2 1/2	29431208	UCFCX13-40	13668	7 5/8	2 3/32	6 1/2	1 5/16	2 3/16	9/16
2 11/16	29431211	UCFCX14-43	14837	8 3/4	2 7/32	7 1/2	1 7/16	2 5/16	9/16
2 15/16	29431215	UCFCX15-47	16074	8 3/4	2 1/4	7 1/2	1 3/8	2 13/32	5/8
3	29431300	UCFCX15-48							
3 7/16	29431307	UCFCX17-55	21559	10 1/4	2 7/16	8 5/8	1 7/16	2 5/8	3/4
3 1/2	29431308	UCFCX18-56	24504	10 1/4	2 25/32	8 5/8	1 11/16	2 7/8	3/4
3 15/16	29431315	UCFCX20-63	29900	10 7/8	3 23/32	9 3/8	2 5/8	3 9/16	7/8
4	29431400	UCFCX20-64							

For sale as complete units, inserts and housings.

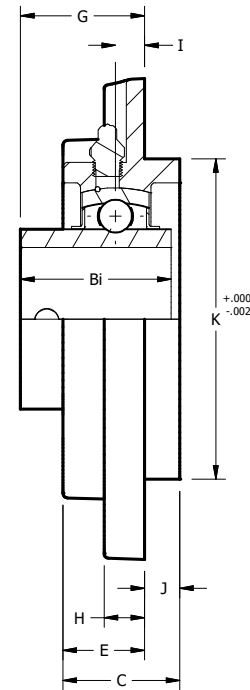
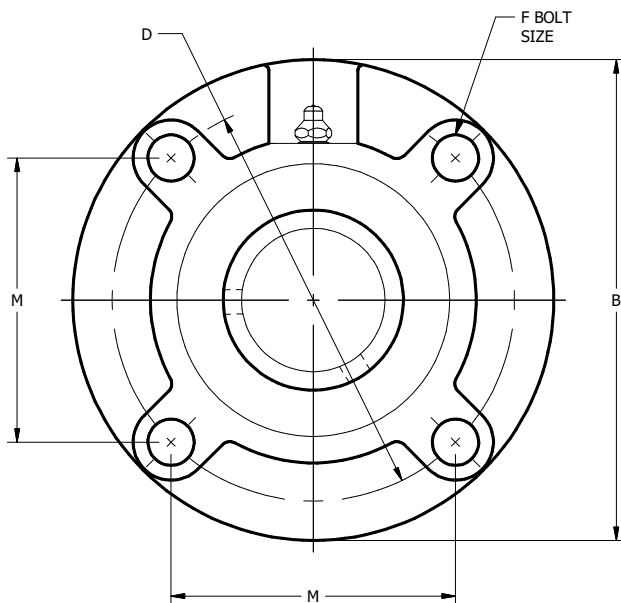

BALL BEARINGS



MEDIUM DUTY UCX PILOTED FLANGE

SHAFT SIZE	DIMENSIONS (INCHES)						INSERT #	HOUSING #	WEIGHT LBS.
	I	J	K	M	Bi	F			
2 1/8 2 3/16 2 1/4	5/32	7/8	5.000	4.23	2.56	1/2	UCX11-34 UCX11-35 UCX11-36	FCX11	9.92
2 3/8 2 7/16	7/16	25/32	5.500	4.59	2.56	1/2	UCX12-38 UCX12-39	FCX12	12.56
2 1/2	7/16	25/32	5.500	4.59	2.94	1/2	UCX13-40	FCX13	14.33
2 11/16	9/16	25/32	6.375	5.28	3.06	5/8	UCX14-43	FCX14	15.87
2 15/16 3	15/32	7/8	6.375	5.28	3.25	5/8	UCX15-47 UCX15-48	FCX15	17.64
3 7/16	13/32	1	7.375	6.10	3.78	3/4	UCX17-55	FCX17	28.40
3 1/2	15/32	13/32	7.375	6.10	4.09	3/4	UCX18-56	FCX18	29.70
3 15/16 4	7/8	13/32	8.125	6.63	4.63	3/4	UCX20-63 UCX20-64	FCX20	40.90



BALL BEARINGS

For personal service 800.242.4633
CAD drawings at no additional charge
For nomenclature see pages 240 and 241

MOLINE BEARING CO.



MEDIUM DUTY UCX SERIES INSERT

UCX Series Insert— Ball Bearing Set Screw Lock

SHAFT SIZE	MOLINE PART #	UNIT #	DIMENSIONS (INCHES)							WEIGHT LBS.
			D	Bi	Be	n	m	G	ds	
1	15403100	UCX 05-16	2.4409	1.500	.748	.626	.874	.236	¼-28	.85
1 ⅛	15403102	UCX 06-18	2.8346	1.689	.787	.689	1.000	.255	⅝-24	1.35
1 ⅜	15403103	UCX 06-19								1.20
1 ½	15403104	UCX 06-20								1.15
1 ⅜	15403106	UCX 07-22	3.1496	1.937	.826	.748	1.189	.315	⅝-24	1.60
1 ⅞	15403107	UCV 07-23								1.55
1 ½	15403108	UCX 08-24	3.3465	1.937	.866	.748	1.189	.315	⅝-24	1.85
1 ⅝	15403110	UCX 09-26	3.5433	2.031	.905	.748	1.283	.354	⅜-24	2.85
1 11/16	15403111	UCX 09-27								2.10
1 ¾	15403112	UCX 09-28								2.00
1 ⅞	15403114	UCX 10-30	3.9370	2.189	.984	.874	1.315	.354	⅜-24	2.85
1 15/16	15403115	UCX 10-31								2.70
2	15403200	UCX 10-32								2.60
2 ⅛	15403202	UCX 11-34	4.3307	2.563	1.063	1.000	1.563	.413	⅜-24	3.70
2 ⅜	15403203	UCX 11-35								3.60
2 ¼	15403204	UCX 11-36								3.40
2 ⅜	15403206	UCX 12-38	4.7244	2.563	1.102	1.000	1.563	.472	⅜-24	4.35
2 7/16	15403207	UCX 12-39								4.25
2 ½	15403208	UCX 13-40	4.9213	2.937	1.181	1.189	1.748	.472	7/16-20	5.25
2 11/16	15403211	UCX 14-43	5.1181	3.063	1.181	1.311	1.752	.472	7/16-20	6.06
2 15/16	15403215	UCX 15-47	5.5118	3.252	1.299	1.311	1.941	.552	7/16-20	7.20
3	15403300	UCX 15-48								7.00
3 7/16	15403307	UCX 17-55	6.2992	3.779	1.456	1.563	2.216	.551	7/16-20	9.85
3 ½	15403308	UCX 18-56	6.6929	4.094	1.535	1.689	2.405	.551	9/16-18	12.60
3 15/16	15403315	UCX 20-63	7.4803	4.626	1.732	1.937	2.689	.629	5/8-18	17.35
4	15403400	UCX 20-64								16.90

BALL BEARINGS



MEDIUM DUTY UCX SERIES INSERT

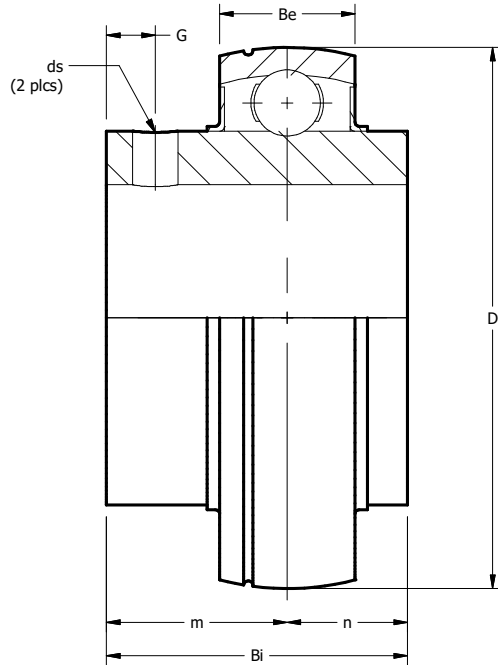

BALL BEARINGS

For personal service 800.242.4633
CAD drawings at no additional charge
For nomenclature see pages 240 and 241

MOLINE BEARING C^o



MOUNTED BALL BEARING APPLICATION GUIDE

LUBRICATION

The proper lubrication of ball bearing units is critical in order to attain maximum bearing life expectancy. **Moline ball bearing units need to be lubricated prior to use.**

They should be re-lubricated periodically, depending on the environment the bearing is exposed to. The following table can be used as a general guide. Experience will determine the best interval for each specific application.

Lubrication Guide

OPERATING CONDITIONS	BEARING TEMPERATURES	GREASE INTERVAL
Clean	32°F to 120°F	6–12 Months
	120°F to 150°F	1–3 Months
	150°F to 200°F	1–4 Weeks
Dirty	32°F to 150°F	1–4 Weeks
	150°F to 200°F	Daily–1 Week
Moisture	32°F to 200°F	Daily–1 Week

The amount and type of lubricant used will affect bearing life. Lack of lubricant can lead to premature surface fatigue failures of balls and races. Over lubrication can damage seals and result in premature failure from contamination due to the inability of damaged seals to keep foreign material out of the bearing.

When lubricating bearings add grease slowly while the shaft is rotating. When the first sign of grease appears at the seals, the bearing will contain the correct amount of lubricant.

Bearings should not run in steady operation over 200°F and should not exceed 225°F for intermittent operation.

For unusual lubrication requirements or severe duty applications, contact Moline Bearing engineering for recommendations.

MOUNTING INSTRUCTIONS

Proper mounting of ball bearing units is critical to unit performance. Failure to follow accepted mounting practice may result in poor performance and short bearing life.

Good engineering and design practice does not recommend the application of more than two bearings to support any shaft. Where more than two bearings are used to support the same shaft, it is possible to induce heavy bearing overloads. In these cases, extreme care must be taken to line up bearings in both the vertical and horizontal planes. When the recommended two bearings are used, alignment is not as critical. Moline Bearing self-aligning mounted bearing units will compensate for minor differences in mounting structure.

For best results, use turned and ground shafts that are free of rough spots and burrs. If an old shaft is used, mount bearing units on a relatively smooth and unworn section.

Prior to mounting, clean both the shaft and the bearing bore. Coat the shaft with a small amount of oil. Slide the bearing unit on the shaft. Do not hammer the ends of the inner race. If necessary to apply some force in mounting, use a soft metal bar or pipe against the inner race only. Tap the bearing unit into place.

Tighten the two set screws securely to lock the bearing to the shaft. In applications where the bearing is subjected to heavy vibration, shock loads, or heavy thrust loads, then it may be desirable to file the shaft flat or drill the shaft slightly in the area where the set screws will contact.

MAXIMUM SPEED

The maximum speed limits listed for the ball bearings can be found in the load rating table. These numbers should be used as a guide and considered along with other factors affecting bearing operation. Load characteristics, bearing lubrication, and temperature factors all influence bearing operation. It is possible that cataloged speed limits may be exceeded after factory engineers complete a complete application analysis.



MOUNTED BALL BEARING APPLICATION GUIDE

BEARING SELECTION

Selection of the proper Moline bearing unit for a determined speed and load can be made by referring to the load rating tables. Proper selection is made by finding a bearing having the desired bore size which has a load rating equal to or greater than the radial or equivalent radial load required for the application.

The ratings shown in the rating tables are based on an average bearing life of 2500 hours. Average bearing life is approximately 5 times L10 life and is the life which may be expected from 50% or more of a given group of bearings operating under identical load conditions. Life expectancies for other than 2,500 hours average life may be determined by using the rating modification factors listed.

BEARING LOADS

Radial loads and thrust force in combination are the principal load components of bearing applied loads. Moline ball bearing unit ratings are based upon the radial load capacity of the bearing. For applications where bearings are required to absorb thrust loads in addition to normal radial loads, the following considerations must be made concerning the magnitude of the thrust force.

When thrust loads are less than half the radial load, the equivalent load should be considered to be the same as the radial load. If the thrust load is equal to or greater than $\frac{1}{2}$ the radial load, the equivalent load is determined by adding the two loads together. For thrust loads equal to or greater than the radial load, consult the factory.

EXAMPLE 1: RADIAL LOAD SERVICE LIFE

Select a mounted bearing flange block to meet the following application requirements.

- Shaft diameter of 1 inch
- Shaft speed is 1500 RPM
- Radial load requirement is 300 lbs.
- Average life requirement is 5000 hours

From the rating table located on the previous page, locate the series bearing corresponding to a one-inch shaft diameter and follow that line to the 1500 RPM

column. The load capacity in this case is 860 lbs. These published radial load capacities are based on an average life of 2,500 hours and must be modified to suit the application requirement 5,000 hours average life by using the proper multiplier from the chart below. Calculate the equivalent radial load capacity for 5,000 hours average life expectancy as follows:

$$\begin{array}{l} 860 \text{ lbs. radial capacity} \\ \times .794 \text{ 5,000 hours avg. life factor} \\ \hline 683 \text{ lbs. radial capacity} \\ \text{for 5,000 hours avg. life} \end{array}$$

EXAMPLE 2: COMBINATION RADIAL AND THRUST LOAD REQUIREMENT

Select a mounted pillow block to meet the following specifications.

- Shaft diameter of $1\frac{3}{16}$
- A Combination load is applied consisting of
Radial Load of 400 lbs.
Thrust Load is 250 lbs.
- Shaft speed is 1000 RPM
- The average life requirement is 2,500 hours

From the load rating table on the previous page, locate the line with the series bearing corresponding to $1\frac{3}{16}$ inch shaft size and follow this line to the right to the 1000 RPM column. The radial load capacity for the bearing is 1389 lbs.

Since the application average life is what the catalog rating charts are based on there's no need to apply further modification factors.

Because the applied thrust load of 250 lbs. is more than half of the applied radial load of 400 lbs., these loads must be added together to obtain the equivalent load requirement.

$$\begin{array}{l} \text{Equivalent load:} \\ 400 \text{ lbs.} + 250 \text{ lbs.} = 650 \text{ lbs.} \end{array}$$

The equivalent radial requirement of 650 lbs. is less than the rated capacity, so the bearing size desired can be used.



NORMAL DUTY RADIAL LOAD RATINGS

Radial Load Ratings In Pounds

SHAFT SIZES	L10 HOURS LIFE	RADIAL LOAD RATINGS AT VARIOUS REVOLUTIONS PER MINUTE											
		50	100	250	500	750	1000	1500	2000	3000	4000	5000	
1/2	5000	1167	926	682	542	473	430	376	341	298	271	251	
	10000	926	735	542	430	376	341	298	271	237	215	200	
	5/8	20000	735	583	430	341	298	271	237	215	188	171	158
	3/4	50000	542	430	317	251	220	200	174	158	138	126	117
	100000	430	341	251	200	174	158	138	126	110	100	93	
7/8	5000	1276	1013	746	592	517	470	411	373	326	296	-----	
	10000	1013	804	592	470	411	373	326	296	259	235	-----	
	15/16	20000	804	638	470	373	326	296	259	235	205	187	-----
	1	50000	592	470	346	275	240	218	191	173	151	137	-----
	100000	470	373	275	218	191	173	151	137	120	109	-----	
1 1/8	5000	1778	1411	1040	825	721	655	572	520	454	413	-----	
	10000	1411	1120	825	655	572	520	454	413	360	327	-----	
	1 3/16	20000	1120	889	655	520	454	413	360	327	286	260	-----
	1 1/4*	50000	825	655	483	383	335	304	266	241	211	191	-----
	100000	655	520	383	304	266	241	211	191	167	152	-----	
1 1/4*	5000	2343	1859	1370	1087	950	863	754	685	598	-----	-----	
	10000	1859	1476	1087	863	754	685	598	544	475	-----	-----	
	1 5/16	20000	1476	1171	863	685	598	544	475	432	377	-----	-----
	1 3/8	50000	1087	863	636	505	441	401	350	318	278	-----	-----
	1 7/16	100000	863	685	505	401	350	318	278	252	220	-----	-----
1 1/2	5000	2698	2142	1578	1252	1094	994	868	789	689	-----	-----	
	10000	2142	1700	1252	994	868	789	689	626	547	-----	-----	
	20000	1700	1349	994	789	689	626	547	497	434	-----	-----	
	50000	1252	994	732	581	508	461	403	366	320	-----	-----	
	100000	994	789	581	461	403	366	320	291	254	-----	-----	
1 5/8	5000	2903	2304	1698	1348	1177	1070	934	849	-----	-----	-----	
	10000	2304	1829	1348	1070	934	849	742	674	-----	-----	-----	
	1 11/16	20000	1829	1452	1070	849	742	674	589	535	-----	-----	
	1 3/4	50000	1348	1070	788	626	546	496	434	394	-----	-----	
	100000	1070	849	626	496	434	394	344	313	-----	-----	-----	
1 7/8	5000	3200	2540	1871	1485	1297	1179	1030	936	-----	-----	-----	
	10000	2540	2016	1485	1179	1030	936	817	743	-----	-----	-----	
	1 15/16	20000	2016	1600	1179	936	817	743	649	589	-----	-----	
	2*	50000	1485	1179	869	689	602	547	478	434	-----	-----	
	100000	1179	936	689	547	478	434	379	345	-----	-----	-----	

* 1 1/4 and 2 inch bearings are offered in two different insert Outside Diameters (O.D.).

BALL BEARINGS



NORMAL DUTY RADIAL LOAD RATINGS - CONTINUED

Radial Load Ratings In Pounds

SHAFT SIZES	L10 HOURS LIFE	RADIAL LOAD RATINGS AT VARIOUS REVOLUTIONS PER MINUTE											
		50	100	250	500	750	1000	1500	2000	3000	4000	5000	
2*	5000	3970	3151	2322	1843	1610	1463	1278	1161	----	----	----	
	10000	3151	2501	1843	1463	1278	1161	1014	921	----	----	----	
	2 1/8	20000	2501	1985	1463	1161	1014	921	805	731	----	----	----
	2 3/16	50000	1843	1463	1078	855	747	679	593	539	----	----	----
		100000	1463	1161	855	679	593	539	471	428	----	----	----
2 1/4	5000	4357	3458	2548	2022	1767	1605	1402	1274	----	----	----	
	10000	3458	2745	2022	1605	1402	1274	1113	1011	----	----	----	
	2 3/8	20000	2745	2179	1605	1274	1113	1011	883	803	----	----	----
	2 7/16	50000	2022	1605	1183	939	820	745	651	591	----	----	----
		100000	1605	1274	939	745	651	591	517	469	----	----	----
2 1/2	5000	5214	4138	3049	2420	2114	1921	1678	----	----	----	----	
	10000	4138	3285	2420	1921	1678	1525	1332	----	----	----	----	
	20000	3285	2607	1921	1525	1332	1210	1057	----	----	----	----	
	50000	2420	1921	1415	1123	981	892	779	----	----	----	----	
	100000	1921	1525	1123	892	779	708	618	----	----	----	----	
2 3/4	5000	5542	4399	3241	2573	2247	2042	1784	----	----	----	----	
	10000	4399	3491	2573	2042	1784	1621	1416	----	----	----	----	
	20000	3491	2771	2042	1621	1416	1286	1124	----	----	----	----	
	50000	2573	2042	1504	1194	1043	948	828	----	----	----	----	
	100000	2042	1621	1194	948	828	752	657	----	----	----	----	
2 15/16 3	5000	6016	4775	3518	2793	2439	2216	1936	----	----	----	----	
	10000	4775	3790	2793	2216	1936	1759	1537	----	----	----	----	
	20000	3790	3008	2216	1759	1537	1396	1220	----	----	----	----	
	50000	2793	2216	1633	1296	1132	1029	899	----	----	----	----	
	100000	2216	1759	1296	1029	899	817	713	----	----	----	----	
3 7/16	5000	8742	6938	5112	4058	3545	3221	----	----	----	----	----	
	10000	6938	5507	4058	3221	2813	2556	----	----	----	----	----	
	20000	5507	4371	3221	2556	2233	2029	----	----	----	----	----	
	50000	4058	3221	2373	1883	1645	1495	----	----	----	----	----	
	100000	3221	2556	1883	1495	1306	1186	----	----	----	----	----	

* 1 1/4 and 2 inch bearings are offered in two different insert Outside Diameters (O.D.).

BALL BEARINGS



MEDIUM DUTY RADIAL LOAD RATINGS

Radial Load Ratings In Pounds

SHAFT SIZES	L10 HOURS LIFE	RADIAL LOAD RATINGS AT VARIOUS REVOLUTIONS PER MINUTE										
		50	100	250	500	750	1000	1500	2000	3000	4000	
1	5000	1778	1411	1040	825	721	655	572	520	454	413	
	10000	1411	1120	825	655	572	520	454	413	360	327	
	20000	1120	889	655	520	454	413	360	327	286	260	
	50000	825	655	483	383	335	304	266	241	211	191	
	100000	655	520	383	304	266	241	211	191	167	152	
1 1/8	5000	2343	1859	1370	1087	950	863	754	685	598	-----	
	10000	1859	1476	1087	863	754	685	598	544	475	-----	
	1 3/16	20000	1476	1171	863	685	598	544	475	432	377	-----
	1 1/4	50000	1087	863	636	505	441	401	350	318	278	-----
	100000	863	685	505	401	350	318	278	252	220	-----	
1 3/8	5000	2698	2142	1578	1252	1094	994	868	789	689	-----	
	10000	2142	1700	1252	994	868	789	689	626	547	-----	
	1 7/16	20000	1700	1349	994	789	689	626	547	497	434	-----
	50000	1252	994	732	581	508	461	403	366	320	-----	
	100000	994	789	581	461	403	366	320	291	254	-----	
1 1/2	5000	2903	2304	1698	1348	1177	1070	934	849	-----	-----	
	10000	2304	1829	1348	1070	934	849	742	674	-----	-----	
	20000	1829	1452	1070	849	742	674	589	535	-----	-----	
	50000	1348	1070	788	626	546	496	434	394	-----	-----	
	100000	1070	849	626	496	434	394	344	313	-----	-----	
1 5/8	5000	3200	2540	1871	1485	1297	1179	1030	936	-----	-----	
	10000	2540	2016	1485	1179	1030	936	817	743	-----	-----	
	1 11/16	20000	2016	1600	1179	936	817	743	649	589	-----	-----
	1 3/4	50000	1485	1179	869	689	602	547	478	434	-----	-----
	100000	1179	936	689	547	478	434	379	345	-----	-----	
1 7/8	5000	3970	3151	2322	1843	1610	1463	1278	1161	-----	-----	
	10000	3151	2501	1843	1463	1278	1161	1014	921	-----	-----	
	1 15/16	20000	2501	1985	1463	1161	1014	921	805	731	-----	-----
	2	50000	1843	1463	1078	855	747	679	593	539	-----	-----
	100000	1463	1161	855	679	593	539	471	428	-----	-----	
2 1/8	5000	4357	3458	2548	2022	1767	1605	1402	1274	-----	-----	
	10000	3458	2745	2022	1605	1402	1274	1113	1011	-----	-----	
	2 3/16	20000	2745	2179	1605	1274	1113	1011	883	803	-----	-----
	2 1/4	50000	2022	1605	1183	939	820	745	651	591	-----	-----
	100000	1605	1274	939	745	651	591	517	469	-----	-----	

BALL BEARINGS



MEDIUM DUTY RADIAL LOAD RATINGS - CONTINUED

Radial Load Ratings In Pounds

SHAFT SIZES	L10 HOURS LIFE	RADIAL LOAD RATINGS AT VARIOUS REVOLUTIONS PER MINUTE									
		50	100	250	500	750	1000	1500	2000	3000	4000
2 3/8 2 7/16	5000	5214	4138	3049	2420	2114	1921	1678	----	----	----
	10000	4138	3285	2420	1921	1678	1525	1332	----	----	----
	20000	3285	2607	1921	1525	1332	1210	1057	----	----	----
	50000	2420	1921	1415	1123	981	892	779	----	----	----
	100000	1921	1525	1123	892	779	708	618	----	----	----
2 1/2	5000	5542	4399	3241	2573	2247	2042	1784	----	----	----
	10000	4399	3491	2573	2042	1784	1621	1416	----	----	----
	20000	3491	2771	2042	1621	1416	1286	1124	----	----	----
	50000	2573	2042	1504	1194	1043	948	828	----	----	----
	100000	2042	1621	1194	948	828	752	657	----	----	----
2 11/16	5000	6016	4775	3518	2793	2439	2216	1936	----	----	----
	10000	4775	3790	2793	2216	1936	1759	1537	----	----	----
	20000	3790	3008	2216	1759	1537	1396	1220	----	----	----
	50000	2793	2216	1633	1296	1132	1029	899	----	----	----
	100000	2216	1759	1296	1029	899	817	713	----	----	----
2 15/16 3	5000	6518	5173	3812	3025	2643	2401	2098	----	----	----
	10000	5173	4106	3025	2401	2098	1906	1665	----	----	----
	20000	4106	3259	2401	1906	1665	1513	1321	----	----	----
	50000	3025	2401	1769	1404	1227	1115	974	----	----	----
	100000	2401	1906	1404	1115	974	885	773	----	----	----
3 7/16	5000	8742	6938	5112	4058	3545	3221	----	----	----	----
	10000	6938	5507	4058	3221	2813	2556	----	----	----	----
	20000	5507	4371	3221	2556	2233	2029	----	----	----	----
	50000	4058	3221	2373	1883	1645	1495	----	----	----	----
	100000	3221	2556	1883	1495	1306	1186	----	----	----	----
3 1/2	5000	9936	7886	5811	4612	4029	3660	----	----	----	----
	10000	7886	6259	4612	3660	3198	2905	----	----	----	----
	20000	6259	4968	3660	2905	2538	2306	----	----	----	----
	50000	4612	3660	2697	2141	1870	1699	----	----	----	----
	100000	3660	2905	2141	1699	1484	1349	----	----	----	----
3 15/16 4	5000	12124	9623	7090	5627	4916	4466	----	----	----	----
	10000	9623	7637	5627	4466	3902	3545	----	----	----	----
	20000	7637	6062	4466	3545	3097	2814	----	----	----	----
	50000	5627	4466	3291	2612	2282	2073	----	----	----	----
	100000	4466	3545	2612	2073	1811	1645	----	----	----	----

BALL BEARINGS



MOUNTED BALL BEARING INTERCHANGE

Normal Duty Mounted Ball Bearing Interchange - UC and HC 200 Series

MOLINE	DODGE	BROWNING	SEALMASTER	HUB CITY	TIMKEN FAFNIR	FYH
UCP 2-Bolt Pillow Block	SC-1	VPS	RP	PB251	SAS	UCP
HCP 2-Bolt Pillow Block Eccentric	SXR-1	VPE	RPE	PB221	RAS	NAP
UCF 4-Bolt Flange	SC-4	VF4S	RF	FB250	SCJ	UCF
HCF 4-Bolt Flange Eccentric	SXR-4	VF4E	RFE	FB220	RCJ	NANF
UCFL 2-Bolt Flange	SC-2	VF2S	RFT	FB260	SCJT	UCFL
HCFL 2-Bolt Flange Eccentric	SXR-2	VF2E	RFTE	FB230	RCJT	NANFL
UCFC Piloted Flange	FCSC	----	----	----	----	UCFC2
HCFC Piloted Flange Eccentric	----	----	----	----	----	----
UCT Wide Slot Take-Up	WSTUSC	VTWS	RT	WSTU250	----	UCT
HCT Wide Slot Take-Up Eccentric	WSTUSXR	VTWE	RT-E	WSTU220	VTU	NAT

Dimensionally compatible with most mounted ball bearings. However, some dimensional variations may exist.

Please verify your engineering data or contact the factory with any questions you may have.



MOUNTED BALL BEARING INTERCHANGE

Medium Duty Mounted Ball Bearing Interchange - UCX Seires

MOLINE	DODGE	BROWNING	SEALMASTER	IPTCI	FYH	AMI
UCPX 2942 2-Bolt Pillow Block	P2B-SCM	VPS-300	MRP	UCPX	UCPX	UCPX
UCFLX 2940 2-Bolt Flange	F2B-SCM	VF2S-300	----	UCFLX	----	UCFLX
UCFX 2941 4-Bolt Flange	F4B-SCM	VF4S-300	MRF	UCFX	UCFX	UCFX
UCFCX 2943 Piloted Flange	FC-SCM	VFCS-300	MRFC	UCFCX	UCFCX	UCFCX

Dimensionally compatible with most mounted ball bearings. However, some dimensional variations may exist. Please verify your engineering data or contact the factory with any questions you may have.

Modification Factors for Average Service Life and Load Conditions

LOAD CONDITIONS	AVERAGE LIFE (1,000 HOURS)													
	2.5	3	4	5	6	7	8	10	15	20	25	30	40	50
Steady Load	1.00	.941	.855	.794	.747	.709	.679	.630	.550	.500	.464	.437	.397	.368
Light Shock	.900	.847	.770	.715	.672	.639	.611	.567	.495	.450	.418	.393	.357	.331
Moderate Shock	.700	.659	.599	.556	.523	.500	.475	.441	.385	.350	.325	.306	.278	.258

Factors are used to modify for loads that are not steady or for average life requirements beyond the standard 2500 hours shown in the Radial Load Rating table.





SHAFT COLLARS

SOLID ZINC PLATED AND STAINLESS STEEL SHAFT COLLARS

SHAFT SIZE	OD	WIDTH	ZINC-PLATED COLLAR #	STAINLESS STEEL COLLAR #	SETSCREW SIZE	WEIGHT (OZ.)
1/8	3/8	1/4	LSC2 x 1/8	SSC2 x 1/8	6-32 x 1/8	0.10
3/16	7/16	1/4	LSC3 x 3/16	SSC3 x 3/16	8-32 x 1/8	0.10
1/4	1/2	9/32	LSC4 x 1/4	SSC4 x 1/4	10-32 x 1/8	0.20
5/16	5/8	5/16	LSC5 x 5/16	SSC5 x 5/16	10-32 x 1/8	0.30
3/8	3/4	3/8	LSC6 x 3/8	SSC6 x 3/8	1/4-20 x 3/16	0.50
7/16	7/8	7/16	LSC7 x 7/16	SSC7 x 7/16	1/4-20 x 1/4	0.80
1/2	1	7/16	LSC8 x 1/2	SSC8 x 1/2	1/4-20 x 1/4	1.10
9/16	1	7/16	LSC9 x 9/16	SSC9 x 9/16	1/4-20 x 1/4	1.00
5/8	1 1/8	1/2	LSC10 x 5/8	SSC10 x 5/8	5/16-18 x 1/4	1.50
11/16	1 1/4	9/16	LSC11 x 11/16	SSC11 x 11/16	5/16-18 x 1/4	2.00
3/4	1 1/4	9/16	LSC12 x 3/4	SSC12 x 3/4	5/16-18 x 1/4	1.90
13/16	1 5/16	9/16	LSC13 x 13/16	SSC13 x 13/16	5/16-18 x 1/4	1.70
7/8	1 1/2	9/16	LSC14 x 7/8	SSC14 x 7/8	5/16-18 x 1/4	2.90
15/16	1 1/2	9/16	LSC15 x 15/16	SSC15 x 15/16	5/16-18 x 1/4	2.74
1	1 5/8	5/8	LSC16 x 1	SSC16 x 1	5/16-18 x 1/4	2.78
1 1/16	1 3/4	5/8	LSC17 x 1 1/16	SSC17 x 1 1/16	5/16-18 x 5/16	4.10
1 1/8	1 3/4	5/8	LSC18 x 1 1/8	SSC18 x 1 1/8	5/16-18 x 5/16	3.90
1 3/16	2	11/16	LSC19 x 1 3/16	SSC19 x 1 3/16	3/8-16 x 3/8	6.10
1 1/4	2	11/16	LSC20 x 1 1/4	SSC20 x 1 1/4	3/8-16 x 3/8	5.70
1 5/16	2 1/8	11/16	LSC21 x 1 5/16	SSC21 x 1 5/16	3/8-16 x 3/8	6.60
1 3/8	2 1/8	3/4	LSC22 x 1 3/8	SSC22 x 1 3/8	3/8-16 x 3/8	6.70
1 7/16	2 1/4	3/4	LSC23 x 1 7/16	SSC23 x 1 7/16	3/8-16 x 3/8	7.60
1 1/2	2 1/4	3/4	LSC24 x 1 1/2	SSC24 x 1 1/2	3/8-16 x 3/8	7.20
1 9/16	2 1/2	13/16	LSC25 x 1 9/16	SSC25 x 1 9/16	3/8-16 x 3/8	10.70
1 5/8	2 1/2	13/16	LSC26 x 1 5/8	SSC26 x 1 5/8	3/8-16 x 3/8	10.10
1 11/16	2 1/2	13/16	LSC27 x 1 11/16	SSC27 x 1 11/16	3/8-16 x 3/8	9.50
1 3/4	2 5/8	7/8	LSC28 x 1 3/4	SSC28 x 1 3/4	1/2-13 x 1/2	11.40

LSC = Zinc Plated Steel.
 SSC = 304 Stainless Steel.
 Collars come with 1 set screw.



SOLID ZINC PLATED AND STAINLESS STEEL SHAFT COLLARS

SHAFT SIZE	OD	WIDTH	ZINC-PLATED COLLAR #	STAINLESS STEEL COLLAR #	SETSCREW SIZE	WEIGHT (OZ.)
1 13/16	2 3/4	7/8	LSC29 x 1 13/16	SSC29 x 1 13/16	1/2-13 x 1/2	12.70
1 7/8	2 3/4	7/8	LSC30 x 1 7/8	SSC30 x 1 7/8	1/2-13 x 1/2	12.20
1 15/16	3	7/8	LSC31 x 1 15/16	SSC31 x 1 15/16	1/2-13 x 1/2	15.70
2	3	7/8	LSC32 x 2	SSC32 x 2	1/2-13 x 1/2	14.90
2 1/8	3	7/8	LSC34 x 2 1/8	SSC34 x 2 1/8	1/2-13 x 1/2	13.30
2 3/16	3 1/4	15/16	LSC35 x 2 3/16	SSC35 x 2 3/16	1/2-13 x 1/2	18.60
2 1/4	3 1/4	15/16	LSC36 x 2 1/4	SSC36 x 2 1/4	1/2-13 x 1/2	17.70
2 5/16	3 1/4	15/16	LSC37 x 2 5/16	-----	1/2-13 x 1/2	16.80
2 3/8	3 1/4	15/16	LSC38 x 2 3/8	SSC38 x 2 3/8	1/2-13 x 1/2	15.90
2 7/16	3 1/2	1	LSC39 x 2 7/16	SSC39 x 2 7/16	1/2-13 x 1/2	21.80
2 1/2	3 1/2	1	LSC40 x 2 1/2	SSC40 x 2 1/2	1/2-13 x 1/2	20.80
2 9/16	3 3/4	1	LSC41 x 2 9/16	-----	1/2-13 x 1/2	25.96
2 5/8	4	1 1/8	LSC42 x 2 5/8	SSC42 x 2 5/8	1/2-13 x 1/2	35.49
2 11/16	4	1 1/8	LSC43 x 2 11/16	SSC43 x 2 11/16	1/2-13 x 1/2	34.40
2 3/4	4	1 1/8	LSC44 x 2 3/4	-----	1/2-13 x 1/2	33.50
2 7/8	4 1/4	1 1/8	LSC46 x 2 7/8	SSC46 x 2 7/8	1/2-13 x 1/2	29.70
2 15/16	4 1/4	1 1/8	LSC47 x 2 15/16	SSC47 x 2 15/16	1/2-13 x 1/2	29.30
3	4 1/4	1 1/8	LSC48 x 3	SSC48 x 3	1/2-13 x 1/2	27.70
3 3/16	4 1/4	1 1/8	LSC51 x 3 3/16	SSC51 x 3 3/16	1/2-13 x 1/2	31.00
3 7/16	4 1/2	1 1/8	LSC55 x 3 7/16	SSC55 x 3 7/16	1/2-13 x 1/2	33.00
3 1/2	4 1/2	1 1/8	LSC56 x 3 1/2	SSC56 x 3 1/2	1/2-13 x 1/2	40.70
3 15/16	5	1 1/8	LSC63 x 3 15/16	SSC63 x 3 15/16	1/2-13 x 1/2	37.60
4	5 1/4	1 3/8	LSC64 x 4	SSC64 x 4	1/2-13 x 1/2	39.00
4 1/4	5 1/2	1 3/8	LSC85 x 4 1/4	-----	1/2-13 x 1/2	55.00
4 7/16	6	1 3/8	LSC90 x 4 7/16	-----	1/2-13 x 1/2	41.20
4 15/16	6 3/8	1 3/8	LSC93 x 4 15/16	-----	1/2-13 x 1/2	53.10

For personal service and special requests, please call us at 800.242.4633.
CAD drawings available upon request at no additional charge.



BLACK OXIDE SINGLE/DOUBLE SPLIT COLLARS

SHAFT SIZE	OD	WIDTH	SINGLE SPLIT PART #	WEIGHT (OZ.)	DOUBLE SPLIT PART #	SETSCREW SIZE	WEIGHT (OZ.)
1/4	1 1/16	5/16	SCS4 x 1/4	0.40	DSC4 x 1/4	4-40 x 3/8	0.38
5/16	1 1/16	5/16	SCS5 x 5/16	0.36	DSC5 x 5/16	4-40 x 3/8	0.34
3/8	7/8	1 1/32	SCS6 x 3/8	0.70	DSC6 x 3/8	6-32 x 3/8	0.71
7/16	1 5/16	3/8	SCS7 x 7/16	0.81	DSC7 x 7/16	6-32 x 3/8	0.76
1/2	1 1/8	1 3/32	SCS8 x 1/2	1.30	DSC8 x 1/2	8-32 x 1/2	1.26
9/16	1 1/4	7/16	SCS9 x 9/16	2.00	DSC9 x 9/16	10-32 x 1/2	2.00
5/8	1 5/16	7/16	SCS10 x 5/8	1.80	DSC10 x 5/8	10-32 x 1/2	1.80
1 1/16	1 3/8	7/16	SCS11 x 1 1/16	2.90	DSC11 x 1 1/16	10-32 x 1/2	2.80
3/4	1 1/2	1/2	SCS12 x 3/4	2.70	DSC12 x 3/4	1/4-28 x 5/8	2.60
1 3/16	1 5/8	1/2	SCS13 x 1 3/16	3.20	DSC13 x 1 3/16	1/4-28 x 5/8	3.10
7/8	1 5/8	1/2	SCS14 x 7/8	2.96	DSC14 x 7/8	1/4-28 x 5/8	2.83
1 5/16	1 3/4	1/2	SCS15 x 1 5/16	3.51	DSC15 x 1 5/16	1/4-28 x 5/8	3.40
1	1 3/4	1/2	SCS16 x 1	3.30	DSC16 x 1	1/4-28 x 5/8	3.10
1 1/16	1 7/8	1/2	SCS17 x 1 1/16	3.90	DSC17 x 1 1/16	1/4-28 x 5/8	3.67
1 1/8	1 7/8	1/2	SCS18 x 1 1/8	3.63	DSC18 x 1 1/8	1/4-28 x 5/8	3.50
1 3/16	2 1/16	1/2	SCS19 x 1 3/16	4.70	DSC19 x 1 3/16	1/4-28 x 5/8	4.50
1 1/4	2 1/16	1/2	SCS20 x 1 1/4	4.40	DSC20 x 1 1/4	1/4-28 x 5/8	4.22
1 5/16	2 1/8	9/16	SCS21 x 1 5/16	6.19	DSC21 x 1 5/16	1/4-28 x 5/8	5.90
1 3/8	2 1/4	9/16	SCS22 x 1 3/8	5.90	DSC22 x 1 3/8	1/4-28 x 5/8	5.70
1 7/16	2 1/4	9/16	SCS23 x 1 7/16	5.50	DSC23 x 1 7/16	1/4-28 x 5/8	5.23
1 1/2	2 3/8	9/16	SCS24 x 1 1/2	6.30	DSC24 x 1 1/2	1/4-28 x 5/8	6.06
1 9/16	2 3/8	9/16	SCS25 x 1 9/16	5.90	DSC25 x 1 9/16	1/4-28 x 5/8	5.61
1 5/8	2 5/8	1 1/16	SCS26 x 1 5/8	9.65	DSC26 x 1 5/8	1/4-28 x 5/8	9.31
1 1 1/16	2 3/4	1 1/16	SCS27 x 1 1 1/16	10.70	DSC27 x 1 1 1/16	5/16-24 x 1	9.86
1 3/4	2 3/4	1 1/16	SCS28 x 1 3/4	10.20	DSC28 x 1 3/4	5/16-24 x 1	11.00

SCS and DSC = Black Oxidized Steel.



BLACK OXIDE SINGLE/DOUBLE SPLIT COLLARS

SHAFT SIZE	OD	WIDTH	SINGLE SPLIT PART #	WEIGHT (OZ.)	DOUBLE SPLIT PART #	SETScrew SIZE	WEIGHT (OZ.)
1 13/16	2 7/8	1 1/16	SCS29 x 1 13/16	10.70	DSC29 x 1 13/16	5/16-24 x 1	12.00
1 7/8	2 7/8	1 1/16	SCS30 x 1 7/8	10.90	DSC30 x 1 7/8	5/16-24 x 1	10.46
1 15/16	3	1 1/16	SCS31 x 1 15/16	12.00	DSC31 x 1 15/16	5/16-24 x 1	11.57
2	3	1 1/16	SCS32 x 2	11.60	DSC32 x 2	5/16-24 x 1	11.00
2 1/16	3 1/8	3/4	-----	-----	DSC33 x 2 1/16	5/16-24 x 1	12.00
2 1/8	3 1/4	3/4	SCS34 x 2 1/8	15.20	DSC34 x 2 1/8	5/16-24 x 1	15.00
2 3/16	3 1/4	3/4	SCS35 x 2 3/16	14.40	DSC35 x 2 3/16	5/16-24 x 1	14.00
2 1/4	3 1/4	3/4	SCS36 x 2 1/4	13.66	DSC36 x 2 1/4	5/16-24 x 1	13.10
2 5/16	3 3/8	3/4	SCS37 x 2 5/16	15.20	DSC37 x 2 5/16	5/16-24 x 1	15.90
2 3/8	3 1/2	3/4	SCS38 x 2 3/8	16.50	DSC38 x 2 3/8	5/16-24 x 1	15.20
2 7/16	3 1/2	3/4	SCS39 x 2 7/16	15.60	DSC39 x 2 7/16	5/16-24 x 1	15.30
2 1/2	3 3/4	7/8	SCS40 x 2 1/2	23.10	DSC40 x 2 1/2	3/8-24 x 1-1/4	22.30
2 9/16	3 7/8	7/8	SCS41 x 2 9/16	22.00	DSC41 x 2 9/16	3/8-24 x 1-1/4	21.00
2 5/8	3 7/8	7/8	-----	-----	DSC42 x 2 5/8	3/8-24 x 1-1/4	24.00
2 11/16	4	7/8	SCS43 x 2 11/16	25.80	DSC43 x 2 11/16	3/8-24 x 1-1/4	25.00
2 3/4	4	7/8	SCS44 x 2 3/4	29.20	DSC44 x 2 3/4	3/8-24 x 1-1/4	24.00
2 13/16	4 1/4	7/8	-----	-----	DSC45 x 2 13/16	3/8-24 x 1-1/4	24.00
2 7/8	4 1/4	7/8	SCS46 x 2 7/8	29.20	DSC46 x 2 7/8	3/8-24 x 1-1/4	29.00
2 15/16	4 1/4	7/8	SCS47 x 2 15/16	28.00	DSC47 x 2 15/16	3/8-24 x 1-1/4	26.50
3	4 1/4	7/8	SCS48 x 3	26.80	DSC48 x 3	3/8-24 x 1-1/4	25.80
3 3/16	4 1/2	7/8	SCS51 x 3 3/16	25.00	DSC51 x 3 3/16	3/8-24 x 1-1/4	28.30
3 7/16	4 3/4	7/8	SCS55 x 3 7/16	25.10	DSC55 x 3 7/16	3/8-24 x 1-1/4	31.00
3 15/16	5 1/4	7/8	SCS63 x 3 15/16	34.00	DSC63 x 3 15/16	3/8-24 x 1-1/4	35.00
4	5 1/4	7/8	SCS64 x 4	33.40	DSC64 x 4	3/8-24 x 1-1/4	33.00
4 7/16	5 3/4	7/8	-----	-----	DSC71 x 4 7/16	3/8-24 x 1-1/4	34.00

SCS and DSC = Black Oxidized Steel.

For personal service and special requests, please call us at 800.242.4633.

CAD drawings available upon request at no additional charge.



STAINLESS STEEL SINGLE/DOUBLE SPLIT COLLARS

SHAFT SIZE	OD	WIDTH	STAINLESS SINGLE SPLIT PART #	WEIGHT (OZ.)	STAINLESS DOUBLE SPLIT PART #	SETScrew SIZE	WEIGHT (OZ.)
1/4	1 1/16	5/16	SSCS4 x 1/4	0.40	SDSC4 x 1/4	4-40 x 3/8	0.38
5/16	1 1/16	5/16	SSCS5 x 5/16	0.36	SDSC5 x 5/16	4-40 x 3/8	0.34
3/8	7/8	1 1/32	SSCS6 x 3/8	0.70	SDSC6 x 3/8	6-32 x 3/8	0.71
7/16	1 5/16	3/8	SSCS7 x 7/16	0.81	SDSC7 x 7/16	6-32 x 3/8	0.76
1/2	1 1/8	13/32	SSCS8 x 1/2	1.30	SDSC8 x 1/2	8-32 x 1/2	1.26
9/16	1 1/4	7/16	SSCS9 x 9/16	2.00	SDSC9 x 9/16	10-32 x 1/2	2.00
5/8	1 5/16	7/16	SSCS10 x 5/8	1.80	SDSC10 x 5/8	10-32 x 1/2	1.80
1 1/16	1 3/8	7/16	SSCS11 x 1 1/16	2.90	SDSC11 x 1 1/16	10-32 x 1/2	2.80
3/4	1 1/2	1/2	SSCS12 x 3/4	2.70	SDSC12 x 3/4	1/4-28 x 5/8	2.60
13/16	1 5/8	1/2	SSCS13 x 13/16	3.20	SDSC13 x 13/16	1/4-28 x 5/8	3.10
7/8	1 5/8	1/2	SSCS14 x 7/8	2.96	SDSC14 x 7/8	1/4-28 x 5/8	2.83
15/16	1 3/4	1/2	SSCS15 x 15/16	3.51	SDSC15 x 15/16	1/4-28 x 5/8	3.40
1	1 3/4	1/2	SSCS16 x 1	3.30	SDSC16 x 1	1/4-28 x 5/8	3.10
1 1/16	1 7/8	1/2	SSCS17 x 1 1/16	3.90	SDSC17 x 1 1/16	1/4-28 x 5/8	3.67
1 1/8	1 7/8	1/2	SSCS18 x 1 1/8	3.63	SDSC18 x 1 1/8	1/4-28 x 3/4	3.50
1 3/16	2 1/16	1/2	SSCS19 x 1 3/16	4.70	SDSC19 x 1 3/16	1/4-28 x 3/4	4.50
1 1/4	2 1/16	1/2	SSCS20 x 1 1/4	4.40	SDSC20 x 1 1/4	1/4-28 x 3/4	4.22
1 5/16	2 1/8	9/16	SSCS21 x 1 5/16	6.19	SDSC21 x 1 5/16	1/4-28 x 3/4	5.90
1 3/8	2 1/4	9/16	SSCS22 x 1 3/8	5.90	SDSC22 x 1 3/8	1/4-28 x 3/4	5.70
1 7/16	2 1/4	9/16	SSCS23 x 1 7/16	5.50	SDSC23 x 1 7/16	1/4-28 x 3/4	5.23
1 1/2	2 3/8	9/16	SSCS24 x 1 1/2	6.30	SDSC24 x 1 1/2	1/4-28 x 3/4	6.06
1 9/16	2 3/8	9/16	SSCS25 x 1 9/16	5.90	SDSC25 x 1 9/16	1/4-28 x 3/4	5.61
1 5/8	2 5/8	1 1/16	SSCS26 x 1 5/8	9.65	SDSC26 x 1 5/8	5/16-24 x 1	9.31

SSCS and SDSC = 304 Stainless Steel.



STAINLESS STEEL SINGLE/DOUBLE SPLIT COLLARS

SHAFT SIZE	OD	WIDTH	STAINLESS SINGLE SPLIT PART #	WEIGHT (OZ.)	STAINLESS DOUBLE SPLIT PART #	SETSCREW SIZE	WEIGHT (OZ.)
1 11/16	2 3/4	1 1/16	SSCS27 x 1 11/16	10.70	SDSC27 x 1 11/16	5/16-24 x 1	9.86
1 3/4	2 3/4	1 1/16	SSCS28 x 1 3/4	10.20	SDSC28 x 1 3/4	5/16-24 x 1	11.00
1 13/16	2 7/8	1 1/16	SSCS29 x 1 13/16	10.40	SDSC29 x 1 13/16	5/16-24 x 1	10.70
1 7/8	2 7/8	1 1/16	SSCS30 x 1 7/8	10.90	SDSC30 x 1 7/8	5/16-24 x 1	10.46
1 15/16	3	1 1/16	SSCS31 x 1 15/16	12.00	SDSC31 x 1 15/16	5/16-24 x 1	11.57
2	3	1 1/16	SSCS32 x 2	11.60	SDSC32 x 2	5/16-24 x 1	11.00
2 1/8	3 1/4	3/4	SSCS34 x 2 1/8	15.20	SDSC34 x 2 1/8	5/16-24 x 1	15.00
2 3/16	3 1/4	3/4	SSCS35 x 2 3/16	14.40	SDSC35 x 2 3/16	5/16-24 x 1	14.00
2 1/4	3 1/4	3/4	SSCS36 x 2 1/4	13.66	SDSC36 x 2 1/4	5/16-24 x 1	13.10
2 5/16	3 3/8	3/4	SSCS37 x 2 5/16	16.00	SDSC37 x 2 5/16	5/16-24 x 1	15.90
2 3/8	3 1/2	3/4	SSCS38 x 2 3/8	16.50	SDSC38 x 2 3/8	5/16-24 x 1	15.20
2 7/16	3 1/2	3/4	SSCS39 x 2 7/16	15.60	SDSC39 x 2 7/16	5/16-24 x 1	15.30
2 1/2	3 3/4	7/8	SSCS40 x 2 1/2	23.10	SDSC40 x 2 1/2	3/8-24 x 1-1/4	22.30
2 9/16	3 7/8	7/8	SSCS41 x 2 9/16	22.00	SDSC41 x 2 9/16	3/8-24 x 1-1/4	21.00
2 5/8	3 7/8	7/8	-----	-----	SDSC42 x 2 5/8	3/8-24 x 1-1/4	24.00
2 11/16	4	7/8	SSCS43 x 2 11/16	25.80	SDSC43 x 2 11/16	3/8-24 x 1-1/4	25.00
2 3/4	4	7/8	SSCS44 x 2 3/4	29.20	SDSC44 x 2 3/4	3/8-24 x 1-1/4	24.00
2 7/8	4 1/4	7/8	SSCS46 x 2 7/8	29.20	SDSC46 x 2 7/8	3/8-24 x 1-1/4	29.00
2 15/16	4 1/4	7/8	SSCS47 x 2 15/16	28.00	SDSC47 x 2 15/16	3/8-24 x 1-1/4	26.50
3	4 1/4	7/8	SSCS48 x 3	26.80	SDSC48 x 3	3/8-24 x 1-1/4	25.80
3 3/16	4 1/2	7/8	SSCS51 x 3 3/16	25.00	SDSC51 x 3 3/16	3/8-24 x 1-1/4	28.30
3 7/16	4 1/2	7/8	SSCS55 x 3 7/16	33.00	SDSC55 x 3 7/16	3/8-24 x 1-1/4	31.00
3 1/2	4 3/4	7/8	-----	-----	SDSC56 x 3 1/2	3/8-24 x 1-1/4	32.00

For personal service and special requests, please call us at 800.242.4633.

CAD drawings available upon request at no additional charge.





NOMENCLATURE
AND
MASTER
INTERCHANGE

NOMENCLATURE



MOUNTED UNIT NOMENCLATURE

Moline Part Number

000 00 0000 0

Bearing Type/Series

- 191** = M2000 Spherical Roller Bearing - Expansion
- 192** = M2000 Spherical Roller Bearing – Non Expansion
- 193** = Type E Tapered Roller Bearing
- 194** = Normal Duty 200 Series Set Screw Locking
- 195** = Normal Duty 200 Series Eccentric Locking
- 196** = M3000 Spherical Roller Bearing with Even-Lok™ – Expansion
- 197** = M3000 Spherical Roller Bearing with Even-Lok™ – Non Expansion
- 291** = ME2000 Spherical E Roller Bearing - Expansion
- 292** = ME2000 Spherical E Roller Bearing - Non Expansion
- 294** = Medium Duty Ball Bearing
- 296** = ME3000 Spherical E Roller Bearing with Even-Lok™ – Expansion
- 297** = ME3000 Spherical E Roller Bearing with Even-Lok™ – Non Expansion
- 393** = Split E1000 Type E Tapered Roller Bearing - Expansion
- 493** = Split E1000 Type E Tapered Roller Bearing - Non Expansion

Housing Type/Style

- 01** = 2-Bolt Flange
- 11** = 4-Bolt Flange
- 21** = 2-Bolt Pillow Block
- 22** = 2-Bolt Split Pillow Block
- 31** = Piloted Flange
- 41** = 4-Bolt Pillow Block
- 42** = 4-Bolt Split Pillow Block
- 51** = Wide Slot Take-Up
- 73** = Split E Cartridge Assembly





Bearing/Shaft Size

- Standard**
- X** = Inches
- XX** = 16th's of an inch
Example: 207 = 2 7/16
- Metric**
- XXX** = mm
Example: 085 = 85mm
- Suffix**
- D** = Double Collar
- E** = Epoxy Finished Housing
- G** = Spring Loaded Garter Seal
- L** = Labyrinth Seal
- N** = Nickel Plated Housing
- SS** = Stainless Steel Coating
- T** = Teflon Coated Housing
- No suffix** = Standard Contact Seal
- Other suffix** = Contact Moline

Example: 19321300 or 193-21-300 = Type E, 2-Bolt Pillow Block, 3" shaft size



NOMENCLATURE

			
2-Bolt Flange 	4-Bolt Flange 	Piloted Flange Cartridge 	Wide Slot Take-Up 

HOUSING IDENTIFICATION

Moline Housing Number

000-00-0000

Housing Type

- 110 = 2-Bolt Flange
- 111 = 4-Bolt Flange
- 112 = 2-Bolt Pillow Block
- 113 = Piloted Flange Cartridge
- 114 = 4-Bolt Pillow Block
- 115 = Wide Slot Take-Up

Bearing Type/Series

- 01 = Type E Tapered Roller Bearing
ME2000 Spherical E Roller Bearing and ME3000 Spherical E Roller Bearing with Even-Lok™
- 21 = M2000 Spherical Roller Bearing and M3000 Spherical Roller Bearing with Even-Lok™
- 31 = 200 Series Normal Duty Ball Bearing
- 32 = Split E 1000 Tapered Roller Bearing
- 42 = 4-Bolt Split Pillow Block
- 61 = UCX Series Medium Duty Ball Bearing

Bearing/Shaft Size

A range of inserts with similar bore can fit in the same housing.
X = Inches
XX = 16th's of an inch
Example: 207 = 2 7/16

Example: 111-01-215 = 4-Bolt Flange - Type E - 2 15/16 (2 and 15)

215 Housing which houses 2 11/16, 2 3/4, 2 15/16, 3, 70mm and 75mm bearing shaft sizes



MASTER INTERCHANGE

Type E Series Interchange

PAGE	MOLINE*	BROWNING*	ROYERSFORD*	SEALMASTER*	TIMKEN*	DODGE
14	2-Bolt Pillow Block 19321	PBE920 True Type E	20-02-0** True Type E	EPB-2 True Type E	E-P2B-TRB** True Type E	P2BE**
16	4-Bolt Pillow Block 19341	PBE920F** True Type E	20-04-0 True Type E	EPB-4** True Type E	E-P4B-TRB True Type E	P4BE
20	4-Bolt Flange 19311	FBE920 True Type E	20-05-0 True Type E	EFB True Type E	E-4BF-TRB True Type E	F4BE
24	Piloted Flange 19331	-----	20-06-0 True Type E	-----	E-PF-TRB True Type E	FCE
26	Wide Slot Take-Up 19351	TUE920 True Type E	20-07-0 True Type E	ETU True Type E	E-TU-TRB True Type E	WSTUE

* True Type E = Timken Cup/Cone Assembly (extended sleeve) and double collar.

** Denotes pillow block center to center dimension slightly different.

Moline Type E can be dimensionally interchanged with the Moline ME2000 and ME3000.

Split E1000 Type E Series Interchange

PAGE	MOLINE *	MOLINE PREFIX	DODGE	SEALMASTER **
30	2-Bolt Pillow Block	39322 (Expansion) 49322 (Non-Expansion)	P2B-EXL-RE P2B-EXL-R	ERP2B-2 RPB-2
34	4-Bolt Pillow Block	39342 (Expansion) 49342 (Non-Expansion)	P4B-EXL-RE P4B-EXL-R	ERP4B-4 RPB-4

* True Type E = Cartridge assembled with Timken Enhanced DEE Cone (highest load rating), made in the USA.

** True Type E = Cartridge assembled with Timken DE Cone.

This is a general dimensional interchange, for exact comparison information, please contact the factory.

Can dimensionally interchange with standard Moline Type E, ME2000 and ME3000 Pillow Block Units.

This is a general dimensional interchange, for exact comparison information, please contact the factory.



MASTER INTERCHANGE

M2000 Single Collar Interchange

PAGE	MOLINE	SKF	DODGE	LINK-BELT	REXNORD	SEALMASTER	BROWNING**	TIMKEN/ QM
60	2-Bolt Pillow Block							
	19121 (Expansion)	SYR	P2BS2000RE	PEB22400H	ZAS2000	USRB5000E	SPB1000E	QAPL
	19221 (Non-Expansion)	SYR-H	P2BS2000R	PB22400H	ZA2000	USRB5000	SPB1000NE	
64	4-Bolt Pillow Block							
	19141 (Expansion)	----	P4BS2000RE	PEB22400FH	ZA2000F	USRBF5000E	SPB1000FE	QAPF
	19241 (Non-Expansion)	----	P4BS2000R	PB22400FH	ZAS2000F	USRBF5000	SPB1000FNE	
68	4-Bolt Flange							
	19111 (Expansion)	FYR	F4BS2000RE*	FEB22400H	----	USFB5000	SFB1000E	QAFL
	19211 (Non-Expansion)	FYR-H	F4BS2000R*	FB22400H	ZB2000*	USFB5000	SFB1000NE	
70	Piloted Flange							
	19131 (Expansion)	FYRP	FCS2000RE	----	----	USFC5000E	SFC1000E	QACW
	19231 (Non-Expansion)	FYRP-H	FCS2000R	FCB22400H	ZBR2000	USFC5000	SFC1000NE	
74	Wide Slot Take-Up							
	19151 (Expansion)	TBR	WSTUS2000RE	----	----	USTU5000E	STU1000E	QATU
	19251 (Non-Expansion)	TBR-H	WSTUS2000R	TB22400H	ZT2000	USTU5000	STU1000NE	

M2000 Double Collar Interchange

PAGE	MOLINE	TIMKEN	REXNORD
60	2-Bolt Pillow Block		
	19121D (Expansion)	QAAPL	ZAS5000
	19221D (Non-Expansion)		ZA5000
64	4-Bolt Pillow Block		
	19141D (Expansion)	QAAPF	ZAS4000F
	19241D (Non-Expansion)		ZA5000F
68	4-Bolt Flange		
	19111D (Expansion)	QA AFL	----
	19211D (Non-Expansion)		----
70	Piloted Flange		
	19131D (Expansion)	QAACW	----
	19231D (Non-Expansion)		ZBR5000
74	Wide Slot Take-Up		
	19151D (Expansion)	QAATU	----
	19251D (Non-Expansion)		ZT5000

* Manufactured in square and round 4-bolt flange.

** Legacy item, has been discontinued.

Can dimensionally interchange with standard Moline M3000.

This is a general dimensional interchange, for exact comparison information, please contact the factory.



MASTER INTERCHANGE CONTINUED

ME2000 Single Collar Interchange (with Type E Dimensions)

PAGE	MOLINE	SKF	REX	LINK-BELT	DODGE	SEALMASTER
90	2-Bolt Pillow Block 29121 (Expansion) 29221 (Non-Expansion)	SYE SYE-H	----- ZEP	EPE-B22400H EP-B22400H	EP2B-S2-000RE EP2B-S2-000R	USRBE5000E USRBE5000
92	4-Bolt Flange 29111 (Expansion) 29211 (Non-Expansion)	----- -----	----- ZEF	EFR-B22400H -----	EF4B-S2-000RE EF4B-S2-000R	USFBE5000E USFBE5000
94	Piloted Flange 29131 (Expansion) 29231 (Non-Expansion)	----- -----	----- -----	----- FCB22400H	----- -----	USFCE5000E USFCE5000

All units have tapered adaptor style locking mechanism.

Assembled with Timken™ Spherical Roller Bearings.

Moline ME2000D can dimensionally interchange with standard Moline Type E, E1000 and ME3000.

ME2000 Double Collar Interchange

PAGE	MOLINE	LINK BELT
90	2-Bolt Pillow Block 19121D (Expansion) 19221D (Non-Expansion)	EPEB22500 EPB22500
92	4-Bolt Flange 19111D (Expansion) 19211D (Non-Expansion)	----- EFB22500
94	Piloted Flange 19131D (Expansion) 19231D (Non-Expansion)	----- -----

Starting at Sizes 1-15/16 add Suffix "D" to part number for Double Collar Spherical.

Assembled with Timken™ Spherical Roller Bearings.

Moline ME2000D can dimensionally interchange with standard Moline Type E, E1000 and ME3000.

This is a general dimensional interchange, for exact comparison information, please contact the factory.



MASTER INTERCHANGE CONTINUED

M3000 Single Collar Interchange

PAGE	MOLINE	SKF CONCENTRA™	SEALMASTER	REX SHURLOK™ ADAPTOR MOUNTED	DODGE IMPERIAL
110	2-Bolt Pillow Block 19621 (Expansion) 19721 (Non-Expansion)	SYR-N SYR-NH	USRB5000A USRB5000	ZAS6000 ZA6000	P2BIP <i>or</i> 0694 -----
112	4-Bolt Pillow Block 19641 (Expansion) 19741 (Non-Expansion)	FSYR-N FSYR-NH	USRBF5000A USRBF5000	ZAS6000-F ZA6000-F	P4BIP <i>or</i> 0695 -----
114	4-Bolt Flange 19611 (Expansion) 19711 (Non-Expansion)	FYR-N* FYR-NH*	USFB5000A USFB5000	ZF6000* ZFS6000*	F4SIP <i>or</i> 0697 -----
116	Piloted Flange 19631 (Expansion) 19731 (Non-Expansion)	FYRP-N FYRP-NH	USFC5000A USFC5000A	----- ZBR6000	FCIP <i>or</i> 0698 -----
118	Wide Slot Take-Up 19651 (Expansion) 19751 (Non-Expansion)	TBR-N TBR-NH	USTU5000A USTU5000	----- ZT6000	WSTUIP <i>or</i> 0693 -----

* Manufacture square and round 4-bolt flange.
Can dimensionally interchange with standard Moline M2000.

ME3000 Single Collar Interchange

PAGE	MOLINE	SKF	SEALMASTER	REX	DODGE
130	2-Bolt Pillow Block 29621 (Expansion) 29721 (Non-Expansion)	SYE-N SYE-NH	USRBE5000A USRBE5000	ZEPS6000 ZEP6000	EP2B-IP-RE EP2B-IP-R
132	4-Bolt Flange 29611 (Expansion) 29711 (Non-Expansion)	----- -----	USFBE5000A USFBE5000	----- ZEF6000	EF4B-IP-RE EF4B-IP-R
134	Piloted Flange 29631 (Expansion) 29731 (Non-Expansion)	----- -----	USFCE5000A USFCE5000	----- -----	EFCIP - 0751 <i>or</i> FCIP - 0698

All units in is interchange have tapered adaptor style locking mechanism.
Can dimensionally interchange with standard Moline Type E, E1000 and ME2000.

This is a general dimensional interchange, for exact comparison information, please contact the factory.



MASTER INTERCHANGE CONTINUED

Normal Duty Mounted Ball Bearing Interchange - 200 Series

PAGE	MOLINE	DODGE	BROWNING	SEALMASTER	HUB CITY	TIMKEN FAFNIR	FYH
164	UCP 2-Bolt Pillow Block	SC-1	VPS	RP	PB251	SAS	UCP
168	UCFL 2-Bolt Flange	SC-2	VF2S	RFT	FB260	SCJT	UCFL
172	UCF 4-Bolt Flange	SC-4	VF4S	RF	FB250	SCJ	UCF
176	UCFC Piloted Flange	FCSC	----	----	----	----	UCFC2
180	UCT Wide Slot Take-Up	WSTUSC	VTWS	RT	WSTU250	----	UCT
186	HCP 2-Bolt Pillow Block Eccentric	SXR-1	VPE	RPE	PB221	RAS	NAP
190	HCFL 2-Bolt Flange Eccentric	SXR-2	VF2E	RFTE	FB230	RCJT	NANFL
194	HCF 4-Bolt Flange Eccentric	SXR-4	VF4E	RFE	FB220	RCJ	NANF
198	HCFC Piloted Flange Eccentric	----	----	----	----	----	----
202	HCT Wide Slot Take-Up Eccentric	WSTUSXR	VTWE	RT-E	WSTU220	VTU	NAT

Dimensionally compatible with most mounted ball bearings. However, some dimensional variations may exist. Please verify your engineering data or contact the factory with any questions you may have.



MASTER INTERCHANGE CONTINUED

Medium Duty Mounted Ball Bearing Interchange - 200 Seires

PAGE	MOLINE	DODGE	BROWNING	SEALMASTER	IPTCI	FYH	AMI
208	UCPX 2942 2-Bolt Pillow Block	P2B-SCM	VPS-300	MRP	UCPX	UCPX	UCPX
212	UCFLX 2940 2-Bolt Flange	F2B-SCM	VF2S-300	-----	UCFLX	-----	UCFLX
214	UCFX 2941 4-Bolt Flange	F4B-SCM	VF4S-300	MRF	UCFX	UCFX	UCFX
218	UCFCX 2943 Piloted Flange	FC-SCM	VFCS-300	MRFC	UCFCX	UCFCX	UCFCX

Dimensionally compatible with most mounted ball bearings. However, some dimensional variations may exist. Please verify your engineering data or contact the factory with any questions you may have.



TERMS AND CONDITIONS OF SALE

PRICES & ACCEPTANCE

All orders are for prompt acceptance only by Moline Bearing Company's (Company) home office in Batavia, Illinois. In the event of an increase or decrease in the Company's prices, the price on any order or contract will be the one in effect at the time of shipment.

TAXES

Any sales, use, consumption or other taxes, customs duties taxes and custom brokerage fees applicable to sale, purchase or use of the products is not included in the price shown on this order and will be paid by the purchaser whenever due.

TERMS

Payment terms are net cash within 30 days from the date of the invoice. Acceptance of all orders is subject to approval of the Company's credit department.

MINIMUM CHARGE

The minimum charge on any order will be \$25.00/U.S. net; parcel post, freight or express charges will be added.

SHIPMENTS

Shipments will be routed to incur the lowest available transportation charges. All premium rate shipping services such as express (air or rail); air freight, etc. will be utilized when requested by the purchaser. The Company will add any additional service charges to the invoice. All shipments, unless otherwise specified, are FOB factory. Claims for shortages, damage or non-delivery in transit will be made by the consignees to the carrier. Request for proof of delivery must be submitted within 90 days from the date of the shipment.

RETURNED GOODS

Goods may be returned within six months of the purchase date, with prior permission and an applicable RGA number. Credits will be issued against the original invoice for future purchases only. A minimum of a 25% restock charge on stock items as well as freight both ways will be deducted from the credit. Goods must be returned in unused, undamaged and "resaleable condition." All credits must be used within six months from the date of issue, or they will be voided.

ORDERS & CANCELLATIONS

All orders are considered firm contracts. If the Company is unable to meet the requested delivery requirements and/or expected shipment dates, the Company will not be liable for any claims for delays beyond the Company's control, nor will the Company accept cancellation or suspension unless mutually agreed upon in writing.

ADDITIONAL CHARGES

Additional charges will be applied to cover the costs of extra packing, special engineering or servicing, or other unusual cost elements such as overtime work authorized by the purchaser which have not been contemplated.

WARRANTY

The Company warrants that products furnished will be free from defects in materials and workmanship under normal use and service for 90 days after delivery of products by the Company.

THE COMPANY'S SOLE OBLIGATION UNDER THIS WARRANTY WILL BE TO REPAIR OR REPLACE ANY DEFECTIVE PRODUCT OR PART WHICH IS RETURNED. TRANSPORTATION WILL BE PREPAID WITHIN THE PERIOD MENTIONED ABOVE WHERE EXAMINATION PROVES TO THE SATISFACTION OF THE COMPANY THAT THE PART OR PRODUCT IS DEFECTIVE.

THIS WARRANTY WILL NOT APPLY TO ANY PRODUCT OR PART WHICH HAS BEEN SUBJECTED TO MISUSE, NEGLIGENCE OR ACCIDENT. THIS WARRANTY, AS SET FORTH ABOVE, IS IN LIEU OF ALL OTHER WARRANTIES EXPRESSED OR IMPLIED, INCLUDING WITHOUT LIMITATION WARRANTIES OF MERCHANTABILITY AND FITNESS FOR A PARTICULAR PURPOSE.

LIMITATION OF LIABILITY

IN NO EVENT SHALL THE COMPANY BE LIABLE FOR ANY LOSS, CLAIM OR DAMAGE CAUSED BY, CONTRIBUTED TO, OR ARISING OUT OF THE ACTS OR OMISSIONS OF PURCHASER OR THIRD PARTIES, WHETHER NEGLIGENT OR OTHERWISE. IN NO EVENT SHALL THE COMPANY'S LIABILITY FOR ANY CAUSE OF ACTION WHATSOEVER EXCEED THE COST OF THE ITEM GIVING RISE TO THE CLAIM, WHETHER BASED IN CONTRACT, WARRANTY, INDEMNITY, OR TORT (INCLUDING NEGLIGENCE AND STRICT LIABILITY). IN NO EVENT SHALL THE COMPANY BE LIABLE FOR ANY INDIRECT, CONSEQUENTIAL, INCIDENTAL OR SPECIAL DAMAGES, INCLUDING, BUT NOT LIMITED TO LOST PROFITS OR OTHER ECONOMIC LOSS.

The terms and conditions of sale stated in this document supersede all others and are subject to change without notice.

Moline Bearing Company, Copyright © 2021
Moline Bearing Company, All rights reserved.



quality mounted bearings

TYPE E TAPERED ROLLER BEARINGS

SPLIT E1000 TAPERED ROLLER BEARING

M2000 SPHERICAL ROLLER BEARINGS

**ME2000 SPHERICAL ROLLER BEARINGS
WITH TYPE E DIMENSIONS**

M3000 EVEN-LOK™ SPHERICAL ROLLER BEARINGS

**ME3000 EVEN-LOK™ SPHERICAL ROLLER BEARINGS
WITH TYPE E DIMENSIONS**

MACHINING AND ENGINEERING SERVICES

SPECIALTY COATINGS

BEARING END CAPS AND BEARING COVERS

PRIVATE LABELING

NORMAL AND MEDIUM DUTY BALL BEARINGS

SHAFT COLLARS



MOLINE BEARING CO.

Post Office Box 99, Batavia, Illinois 60510, USA

630.584.4600, 800.242.4633, 630.584.1999 fax, www.molinebearing.com

800.242.4633